

**TECO**  **Westinghouse**

OUTLINE DIMENSIONS

MOTOR TYPE:  
AEEHNH

DATE 05/25/2017

3-PHASE INDUCTION MOTOR

FRAME NO. 254TP

Pole	HP	kW	Hz	VOLT	r/min(rpm)
4	15	11	60	230/460	1800
Ins	Rating	Dimension in	Approx Weight	Bearings	
F	CONT.	Inch	350	DE 6309ZZC3 NDE: 7311B	

Totally Enclosed Fan-Cooled Vertical Type Squirrel-Cage Rotor.

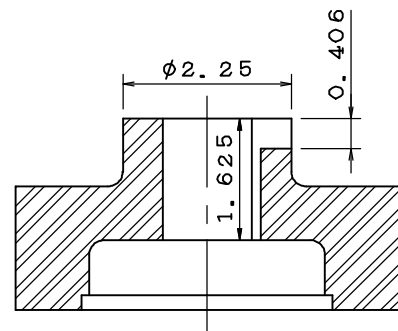
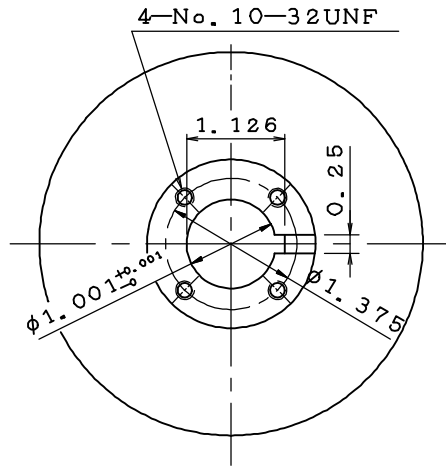
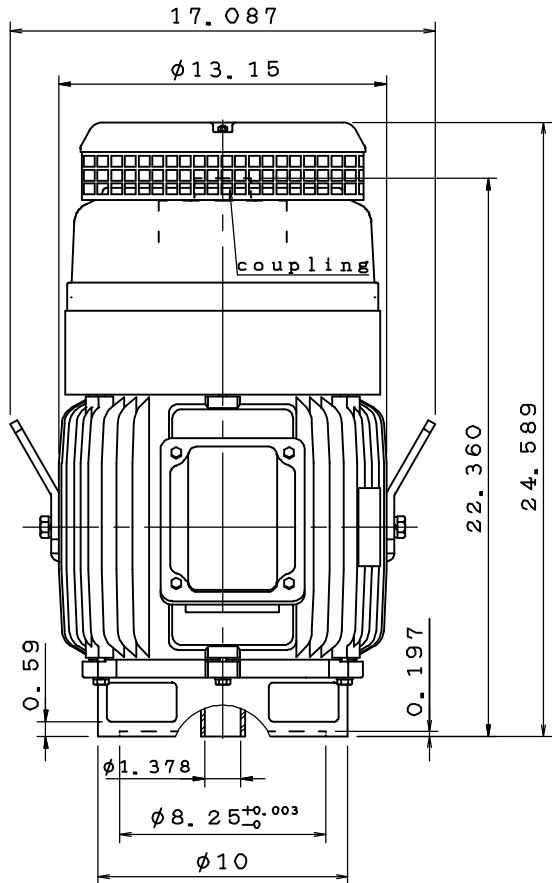

Coupling Dimension

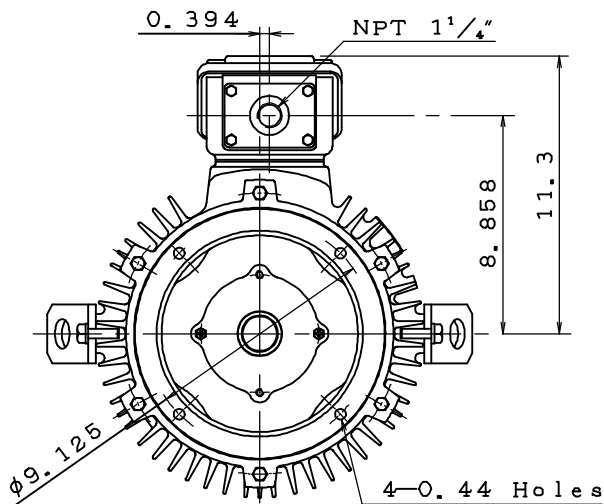

Note:

1. IP44 Protection.
2. Rotation: C. C. W.  
(View from top)
3. With Ball Type N. R. R.
4. Thrust: 2700 lbs  
(L<sub>10</sub>: 8800 hours)

TA17129-00-00

CATALOG# VHTP0154

DWG.	周書緯	03.03.17
CHKD.	徐聰豪	03.03.17
APPD.	徐聰豪	03.03.17

**TECO**  **Westinghouse**

DWG NO.  
31057A385170

# TECO Westinghouse

ISSUED <b>January 17, 2017</b>	<b>PERFORMANCE DATA</b>	ENCLOSURE <b>TEFC</b>
TYPE <b>AEEHNH</b>	<b>3-PHASE INDUCTION MOTOR</b>	CATALOG# <b>VHTP0154</b>

### NAMEPLATE INFORMATION

OUTPUT		POLE	FRAME SIZE	VOLTAGE	HZ	RATED AMBIENT	INS. CLASS	NEMA DESIGN	TIME RATING	SERVICE FACTOR
HP	KW									
<b>15</b>	<b>11.2</b>	<b>4</b>	<b>254TP</b>	<b>230/460</b>	<b>60</b>	<b>40°C</b>	<b>F</b>	<b>B</b>	<b>CONT.</b>	<b>1.15</b>

### TYPICAL PERFORMANCE

FULL LOAD RPM	EFFICIENCY				POWER FACTOR			MAXIMUM POWER FACTOR CORRECTION
	FULL LOAD		3/4 LOAD %	1/2 LOAD %	F. L. %	3/4 LOAD %	1/2 LOAD %	
	MIN. %	NOM. %						
<b>1765</b>	<b>91.0</b>	<b>92.4</b>	<b>93.0</b>	<b>92.4</b>	<b>88.0</b>	<b>85.0</b>	<b>77.0</b>	<b>4.8 KVAR</b>

### CURRENTS

NO LOAD			FULL LOAD			LOCKED ROTOR			NEMA KVA CODE LETTER
AT	AT	AT	AT	AT	AT	AT	AT	AT	
208 VOLT	230 VOLT	460 VOLT	208 VOLT	230 VOLT	460 VOLT	208 VOLT	230 VOLT	460 VOLT	
<b>14.77</b>	<b>12.08</b>	<b>6.04</b>	<b>38.20</b>	<b>34.55</b>	<b>17.27</b>	<b>256.54</b>	<b>232.00</b>	<b>116.00</b>	<b>G</b>

### TORQUE

### INERTIA

### ACCEL TIME

FULL LOAD lb-ft	LOCKED ROTOR %FLT	PULL UP %FLT	BREAK DOWN %FLT	ROTOR WR <sup>2</sup> lb-ft <sup>2</sup>	NEMA LOAD WK <sup>2</sup> lb-ft <sup>2</sup>	MAX ALLOWABLE WK <sup>2</sup> lb-ft <sup>2</sup>	NEMA LOAD WK <sup>2</sup> Sec	MAX ALLOWABLE WK <sup>2</sup> Sec
<b>45</b>	<b>245</b>	<b>180</b>	<b>270</b>	<b>2.179</b>	<b>75</b>	<b>220</b>	<b>4.27</b>	<b>12.23</b>

SAFE STALL TIME IN SECONDS

ALLOWABLE STARTS PER HOUR

COLD

HOT

COLD

HOT

**32**

**22**

**2**

**1**

APPROVED:

**M. PRATER**

DRAWING NO.

**31057VHTP0154**

REVISION **0**

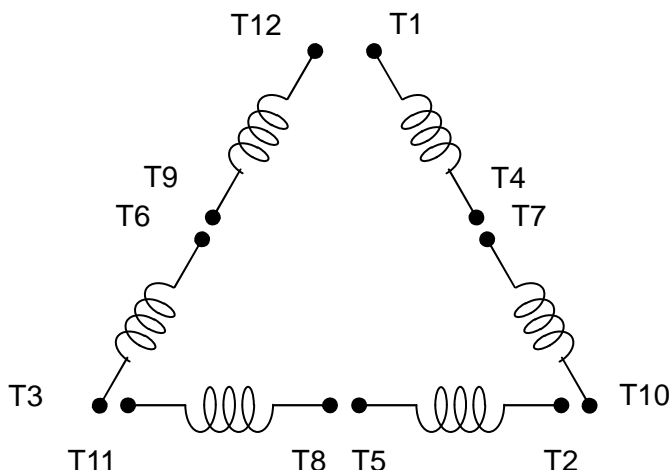

**SCHEMATIC – 2Δ/2Y/Δ/Y CONNECTION**

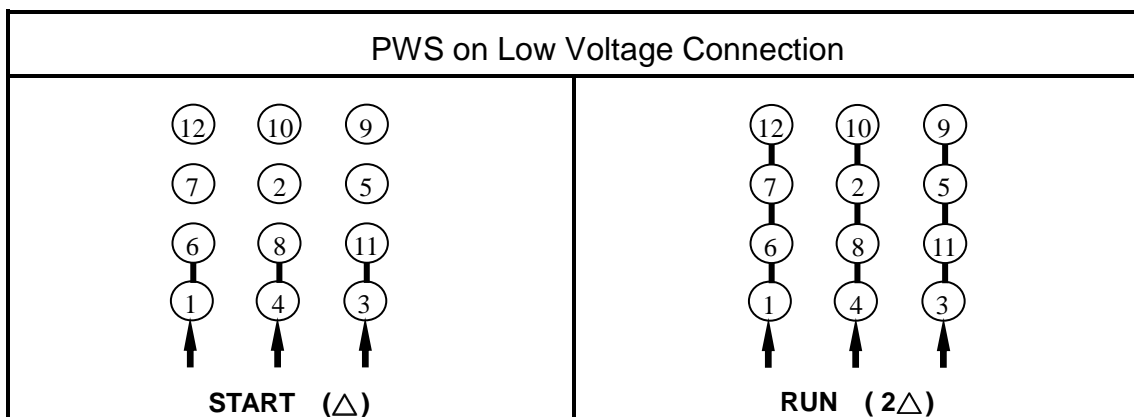
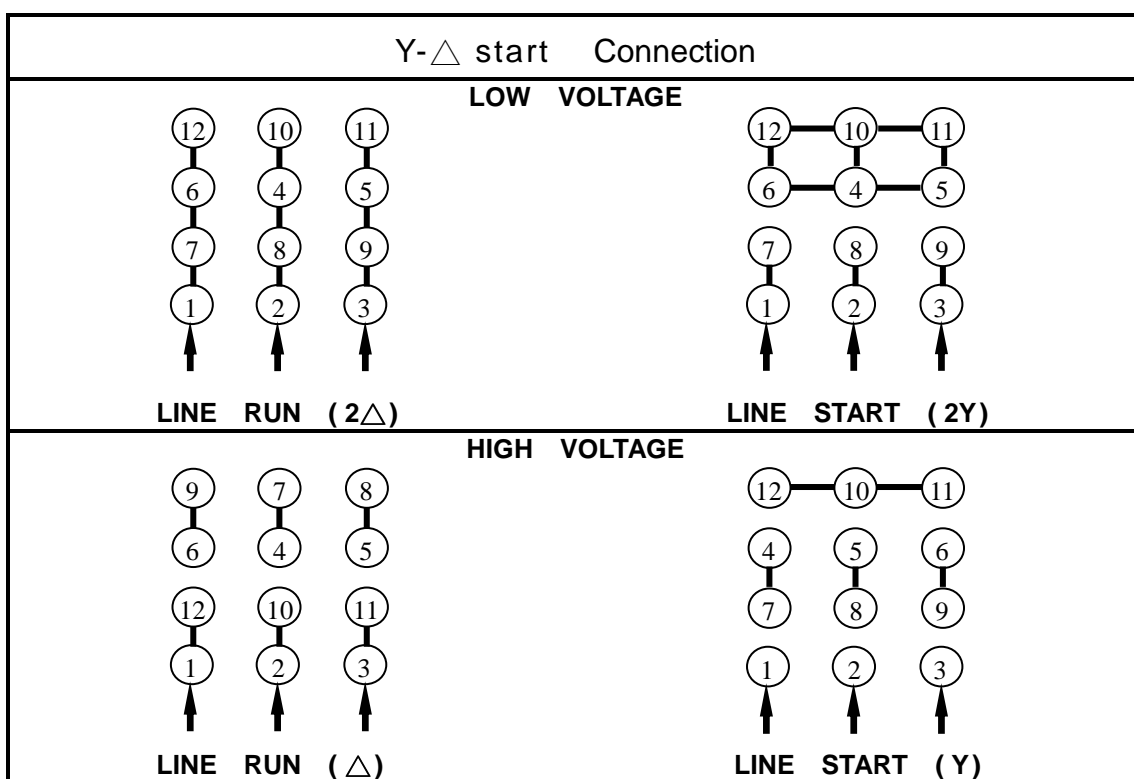

APPD.	M.C.Tsai	May,01,'09	<b>TECO Electric &amp; Machinery Co., Ltd.</b>	DWG NO :
CHKD.	C.L.Huang	May,01,'09		DAC-1705
DWN.	J.C.Lan	May,01,'09		