



OUTLINE DIMENSIONS

MOTOR TYPE:
AEEHNH
FRAME NO. 324TP

DATE 05/25/2017

3-PHASE INDUCTION MOTOR

Pole	HP	kW	Hz	VOLT	r/min
6	25	18.65	60	230/460	1200
Ins	Rating	Dimension in	Approx Weight	Bearings	
F	CONT.	inches	725	DE:6312C3 NDE:7315BE	

Totally Enclosed Fan Cooled Vertical Type. Squirrel-cage Rotor.

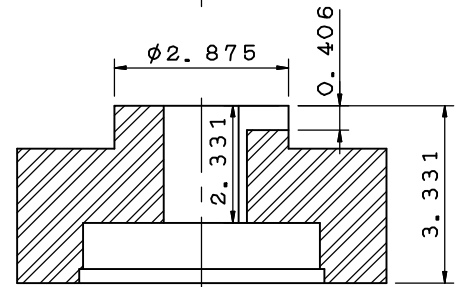
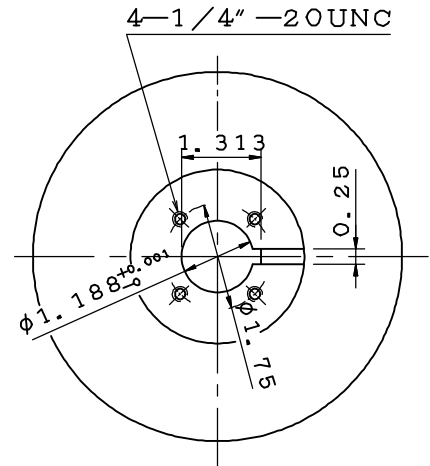
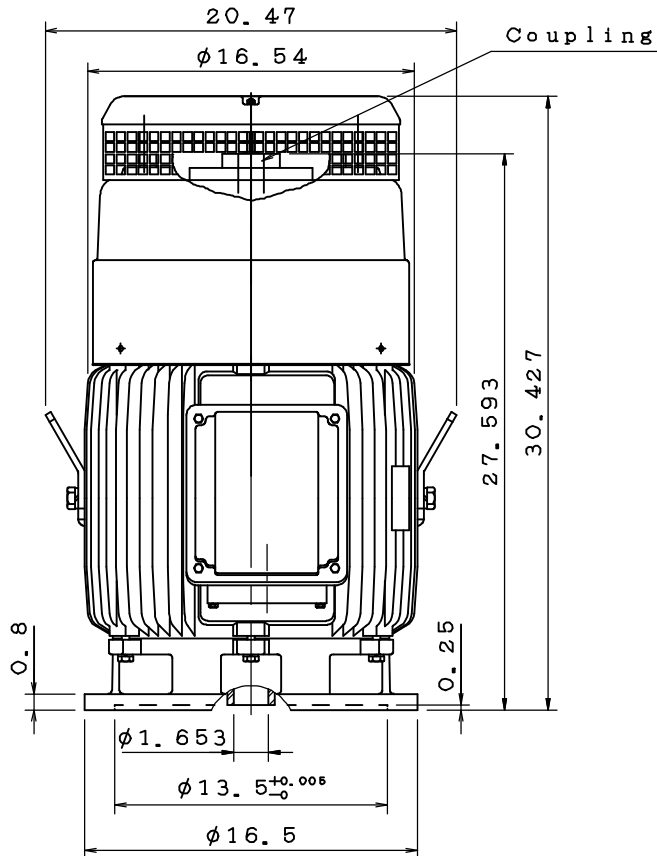

Coupling Dimension

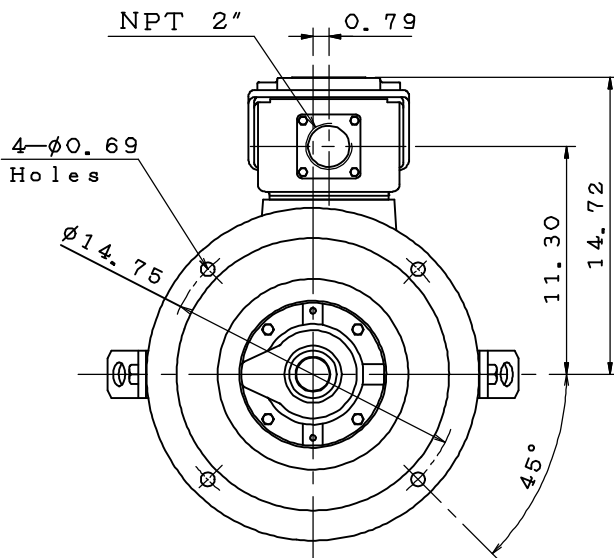

Note:

1. IPW44 Protection.
2. With Ball Type N. R. R.
3. Trust: 4500 lbs.
(L_{10} : 8800 hours)

TA17129-00-00



CATALOG# VHTP0256

DWG.	林志孝	02.07.17	東元電機股份有限公司 TECO Electric & Machinery Co., Ltd. TAIWAN	DWG NO.	31057A556250
CHKD.	林志孝	02.07.17			
APPD.	徐聰豪	02.07.17			

TECO Westinghouse

ISSUED January 17, 2017	PERFORMANCE DATA	ENCLOSURE TEFC
TYPE AEEHNH	3-PHASE INDUCTION MOTOR	CATALOG# VHTP0256

NAMEPLATE INFORMATION

OUTPUT		POLE	FRAME SIZE	VOLTAGE	HZ	RATED AMBIENT	INS. CLASS	NEMA DESIGN	TIME RATING	SERVICE FACTOR
HP	KW									
25	18.7	6	324TP	230/460	60	40°C	F	B	CONT.	1.15

TYPICAL PERFORMANCE

FULL LOAD RPM	EFFICIENCY				POWER FACTOR			MAXIMUM POWER FACTOR CORRECTION
	FULL LOAD		3/4 LOAD %	1/2 LOAD %	F. L. %	3/4 LOAD %	1/2 LOAD %	
	MIN. %	NOM. %						
1170	91.7	93.0	93.6	93.6	83.0	80.0	71.5	6.9 KVAR

CURRENTS

NO LOAD			FULL LOAD			LOCKED ROTOR			NEMA KVA CODE LETTER
AT	AT	AT	AT	AT	AT	AT	AT	AT	
208 VOLT	230 VOLT	460 VOLT	208 VOLT	230 VOLT	460 VOLT	208 VOLT	230 VOLT	460 VOLT	
21.2	17.3	8.7	67	61	30	404	365	183	G

TORQUE

INERTIA

ACCEL TIME

FULL LOAD lb-ft	LOCKED ROTOR %FLT	PULL UP %FLT	BREAK DOWN %FLT	ROTOR WR ² lb-ft ²	NEMA LOAD WK ² lb-ft ²	MAX ALLOWABLE WK ² lb-ft ²	NEMA LOAD WK ² Sec	MAX ALLOWABLE WK ² Sec
112	200	155	205	11.88	324	800	6.11	14.79

SAFE STALL TIME IN SECONDS

ALLOWABLE STARTS PER HOUR

COLD

HOT

COLD

HOT

45

32

2

1

APPROVED:

M. PRATER

DRAWING NO.

31057VHTP0256

REVISION **0**

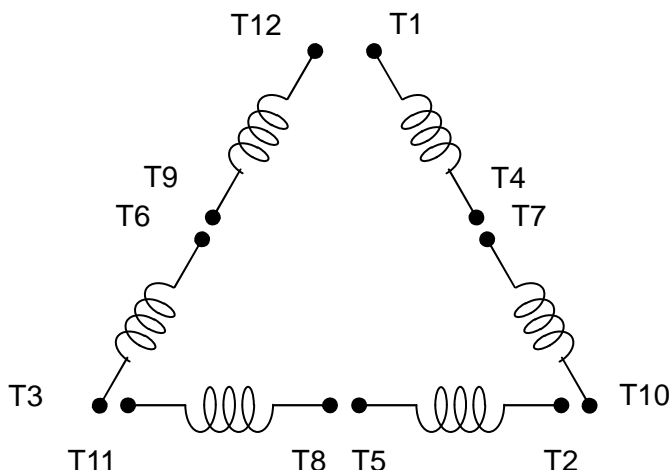

SCHEMATIC – 2Δ/2Y/Δ/Y CONNECTION

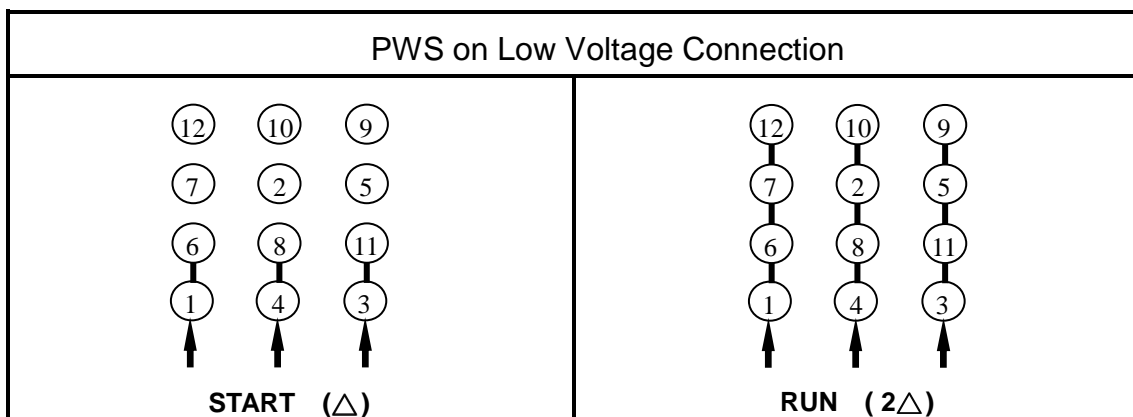
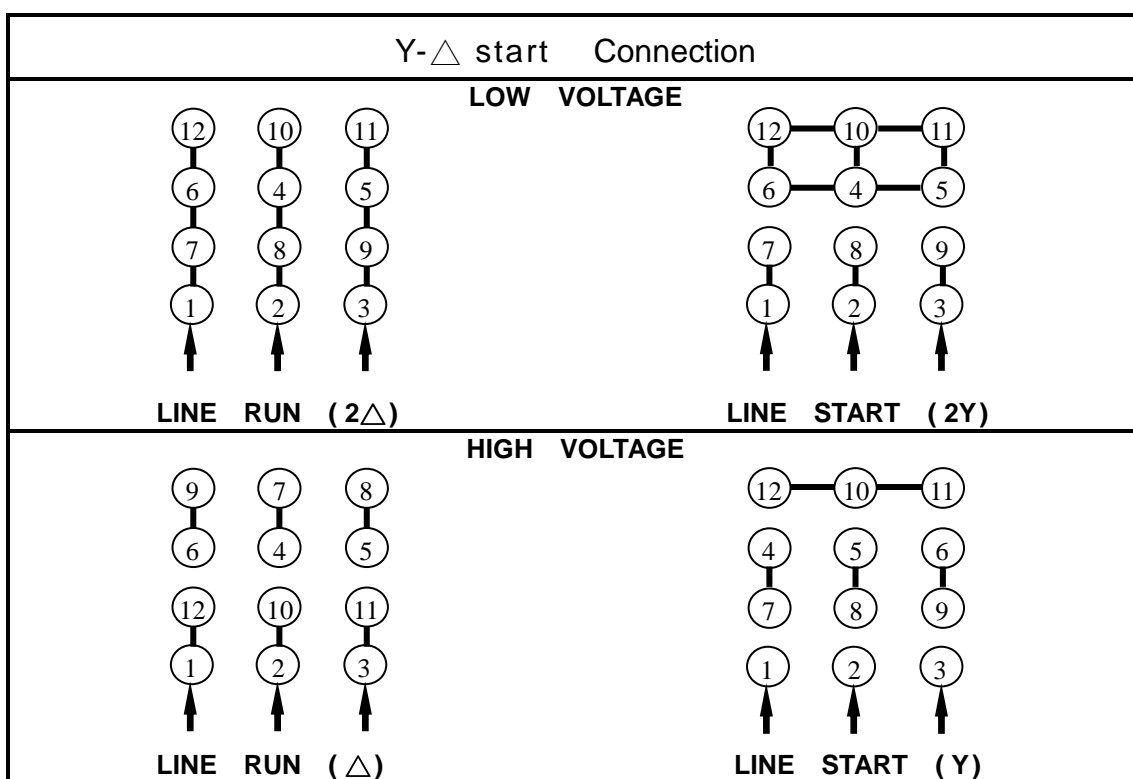

APPD.	M.C.Tsai	May,01,'09	TECO Electric & Machinery Co., Ltd.	DWG NO :
CHKD.	C.L.Huang	May,01,'09		DAC-1705
DWN.	J.C.Lan	May,01,'09		