

TYPE	OUTPUT		POLE	TIME RATING	VOLTAGE V	Hz	SYN. SPEED R.P.M
	HP.	kW.					
AEHNNH	100	74.6	6	CONT	230/460	60	1200

TOTALLY ENCLOSED FAN-COOLED VERTICAL HOLLOW SHAFT TYPE, SQUIRREL CAGE ROTOR

- NOTE:
- DIMENSIONS IN INCH
 - FRAME NO.444TP
 - F CLASS INSULATION, S.F.: 1.15
 - FOR DIRECT COUPLING.
 - BEARING SIZE:
UPPER BEARING: 7324B (UNINSULATED)
LOWER BEARING: 6316C3 (UNINSULATED)
 - LUBRICATION:
UPPER BEARING USE OIL.
OIL VISCOSITY: ISO VG68 [300SSU AT 100°F]
OIL QUANTITY: 2.6 GAL.
LOWER BEARING USE GREASE.(MOBIL POLYREX EM)
ROTATION: COUNTER-CLOCKWISE [VIEW FROM TOP].
 - WITH NON-REVERSE RATCHET MECHANISM.
 - WITH GIB KEY:0.375X0.375X2.874,1PCS
 - APPROXIMATE WEIGHT: 1950
 - REED FREQUENCY: 43 HZ
 - DOWNTHRUST: 10,100 LBS (L10-8800HRS)
 - SPACE HEATER RATED AT 120 VOLT, SINGLE PHASE, 109 WATTS, LEADS TERMINATE IN MAIN LEAD BOX.

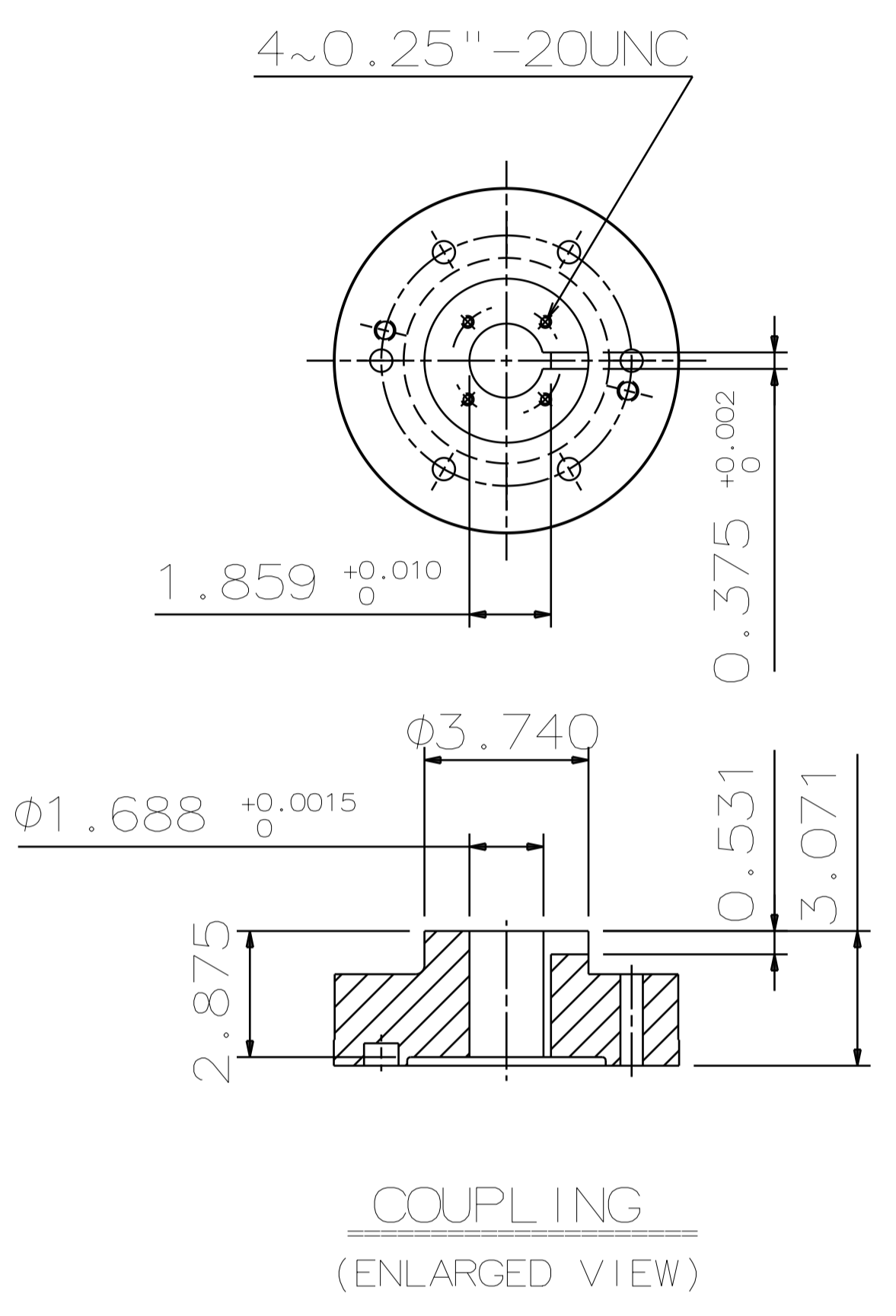

- (A) OIL FILLER [UPPER BEARING]
- (B) OIL GAUGE [UPPER BEARING]
- (C) OIL DRAIN [UPPER BEARING]
- (D) GREASE INLET [LOWER BEARING]
- (E) GREASE DISCHARGER [LOWER BEARING]
- (F) 2~M16 VERTICAL JACKING HOLES 180° APART IN MOTOR BASE.
- (G) M10 TAPPED HOLE IN MOTOR BASE WITH GROUNDING TERMINAL [R38-10] & BOLT LOCATED AS SHOWN.

DATE		DEC 08 2016		OUTLINE DIMENSIONS	
VHTP1006		3-PHASE INDUCTION MOTOR		DWG NO. REV:00	
TECO Westinghouse		4B040L241		1	

DWN.	C.FU	APR.28.2015
CHKD.	R.LEE	APR.28.2015
APPD.	C.LIU	APR.28.2015

ISSUED APR. 30 2015	PERFORMANCE DATA HIGH THRUST HOLLOWSHAFT PUMP MOTORS LOW VOLTAGE SQUIRREL CAGE	MODEL AEEHNH
REVISED		



TEFC, NEMA T-FRAME DESIGN B, CODE G, CLASS F, 40°C AMBIENT,
CONTINUOUS DUTY, 1.15 S.F. 230/460V 60HZ

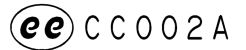

TYPICAL PERFORMANCE

(460V)

HP	FULL LOAD	FRAME SIZE	EFFICIENCY				POWER FACTOR			CURRENT		TORQUE			ROTOR WR ²	DOWN THRUST LBS	APPROX. ROTOR WEIGHT LBS	APPROX. WEIGHT LBS	REED FREQ. Hz
			FULL LOAD %		3/4 LOAD	1/2 LOAD	FULL LOAD	3/4 LOAD	1/2 LOAD	FULL LOAD	LOCKED ROTOR	FULL LOAD	LOCKED ROTOR	BREAK-DOWN					
	RPM	(EHV)	NOM.	MIN.	NOM.	NOM.	%	%	%	A	A	lb-ft	%FLT	%FLT	lb-ft ²	LBS	LBS	LBS	Hz
100	1186	444TP	95.0	94.1	94.9	94.5	79.8	74.8	64.8	123	791	442.9	100	220	56.8	10100	490	1950	43
	890	447TP	94.5	93.6	94.4	94.0	76.0	71.0	61.0	130	791	590.2	100	220	119.6	12600	690	2390	44
125	1781	444TP	95.4	94.5	95.3	94.9	85.6	80.6	70.6	143	988	368.7	100	210	36.1	8900	400	1960	43
	1186	445TP	95.0	94.1	94.9	94.5	79.0	74.0	64.0	155	988	553.7	100	220	66.9	10100	550	2060	40
	889	447TP	95.0	94.1	94.9	94.5	76.2	71.2	61.2	161	988	738.6	100	220	140.4	12600	770	2570	43
150	1781	445TP	95.8	95.0	95.7	95.3	88.0	83.0	73.0	166	1186	442.4	100	210	47.9	8900	470	1990	41
	1188	447TP	95.8	95.0	95.7	95.3	77.2	72.2	62.2	189	1186	663.3	100	210	97.7	11500	640	2440	44
	890	449TP	95.0	94.1	94.9	94.5	76.6	71.6	61.6	192	1186	885.4	100	220	189.6	12600	970	2990	35
200	1781	447TP	96.2	95.4	96.1	95.7	82.5	77.5	67.5	235	1581	589.9	100	200	62.2	10100	530	2420	44
	1188	449TP	95.8	95.0	95.7	95.3	76.6	71.6	61.6	254	1581	884.4	100	210	123.2	11500	750	2850	36
250	1783	449TP	96.2	95.4	96.1	95.7	83.1	78.1	68.1	292	1977	736.6	100	210	79.3	10100	620	2840	36
	1188	449TP	95.8	95.0	95.7	95.3	74.3	69.3	59.3	328	1977	1105.5	100	210	145.1	11500	840	3110	34
300	1783	449TP	96.2	95.4	96.1	95.7	83.1	78.1	68.1	351	2372	883.9	100	220	93.0	10100	690	3070	34

NOTE : 1. THE ABOVE ARE TYPICAL VALUES BASED ON TEST ACCORDING TO ANSI/IEEE STANDARD 112 METHOD B.

2. BREAKDOWN & LOCKED ROTOR TORQUES ARE SHOWN AS AVERAGE EXPECTED VALUES.

3. EFFICIENCY, POWER FACTOR, SPEED AND TORQUE ARE THE SAME FOR OTHER VOLTAGES. CURRENT VALUES VARY INVERSELY WITH VOLTAGE.

4. DECLARED EFFICIENCY HAVN'T TAKEN INTO ACCOUNT OF THRUST LOAD LOSSES

5. TOLERANCE ACCORDING TO NEMA MG1-12& IEC 34-1

6. THRUST LOAD LOSSES ESTIMATED OF ANGULAR CONTACT BALL BEARING AS FOLLOWS : (ACCORDING TO NEMA STANDARD MG1-12.7)

FRAME SIZE	LOSS HP /100 RPM RPM/1000 LB THRUST
444TP~445TP	0.0180
447TP~449TP	0.0194

7. REDUCING THE THRUST LOAD WILL INCREASE BEARING LIFE AS FOLLOWS :

THRUST(%)	100	82	73	63	56	51
BEARING LIFE(Hrs.)	8800	15000	20000	30000	40000	50000

8. DATA SUBJECT TO CHANGE WITHOUT NOTICE

9. ee CC002A IS SUITABLE FOR 4, 6 POLE UP TO 200HP.

10. 230/460 V UP TO 125HP, 150HP AND ABOVE, APPLY 460/(800) V ONLY

APPD.	M.Y.HSU	JUL. 30 2013	TECO Electric & Machinery Co., Ltd.	DWG NO.	3A057M068E
CHKD.	H.Y.WANG	JUL. 30 2013		REV.00	
DWN.	H.Y.WANG	JUL. 30 2013		1/1	

6 5 4 3 2 1

D
C
B
A

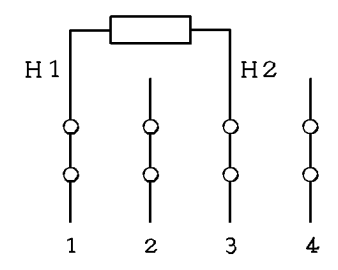
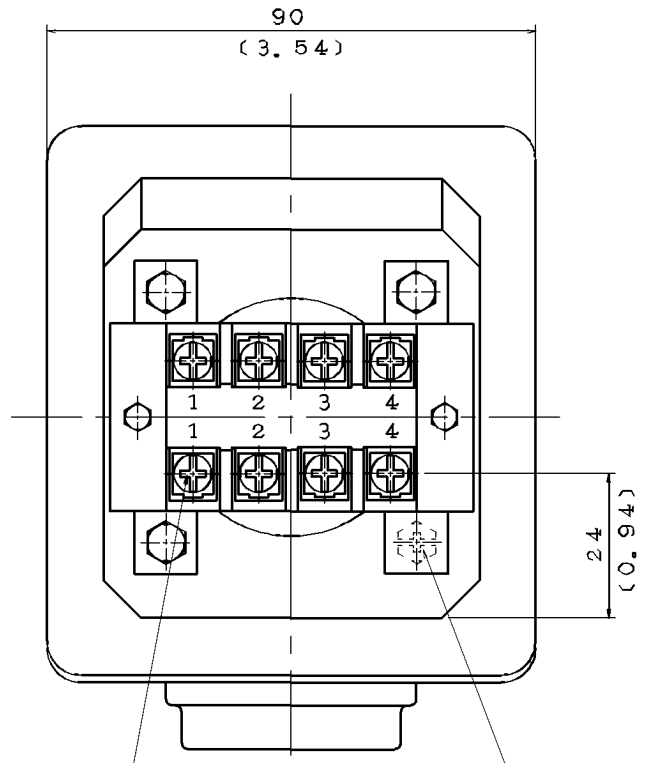
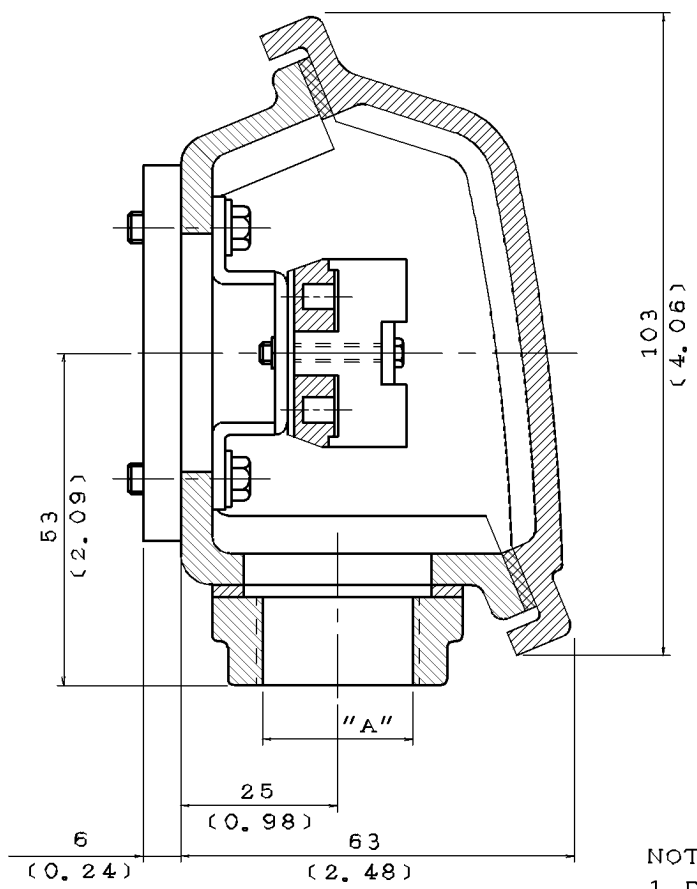

M4 SCREW FOR CONNECTION

M5 EARTH BOLT

- NOTE:
1. DIMENSIONS IN mm (inch)
 2. TW-06
 3. SPACE HEATER T-BOX.
 4. ENCLOSURE: IP55
 5. MATERIAL: CAST IRON

ITEM	A
01	M20×1.5
02	PF-0.5"
03	PF-0.75"
04	PT-0.5"
05	PT-0.75"
06	NPT-0.5"
07	NPT-0.75"
08	M25×1.5
09	PF1"
10	NPT1"
11	PG16

DATE _____ SCHEMATIC DRAWING
TERMINAL BOX

DWN.	H. HUANG	JUN 19 200
CHKD.	H. HUANG	JUN 19 200
APPD.	C. WANG	JUN 19 200

TECO Westinghouse

DWG NO. 3A040U272 REV:09

6 5 4 3 2 1

TECO

CONNECTION DIAGRAM

MODEL

DATE :
DEC.04.'02

For Δ/Δ connection

DAC-1545-1

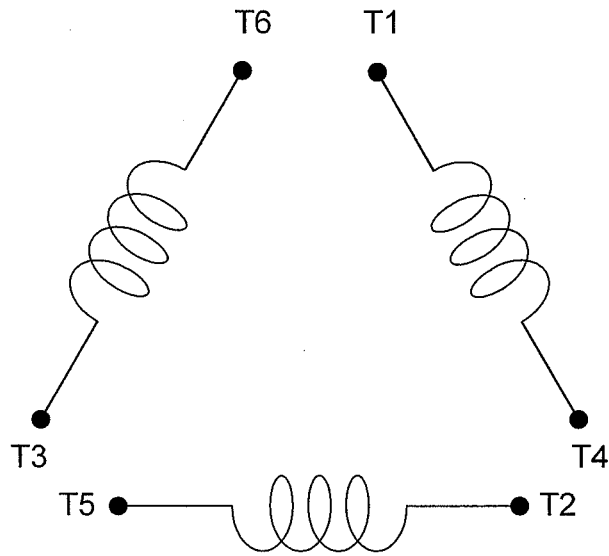

SCHEMATIC - Δ/Δ CONNECTION

ROTATION

(VIEWED FROM DRIVE END)

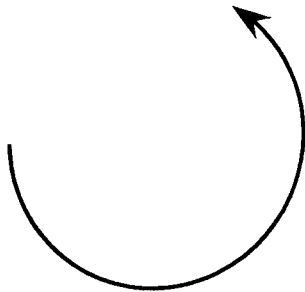

CONNECTION

$\Delta-\Delta$ START

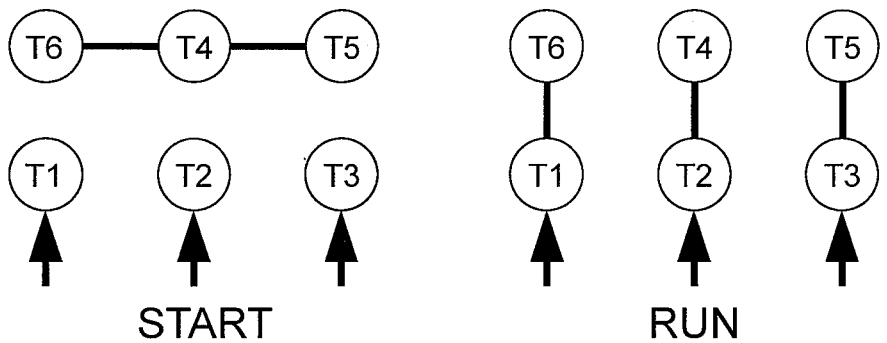

ACROSS-THE-LINE

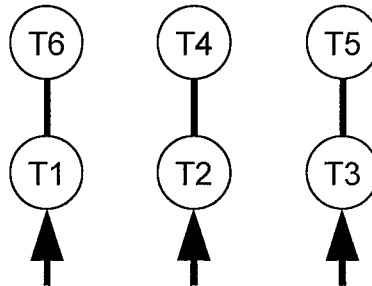

承 認		
審 核	蔡	Dec.05.02
校 對	林	Dec.04.02
繪 製	林賢龍	DEC,04,'02

東元電機股份有限公司
TECO ELECTRIC & MACHINERY CO., LTD.
 TAIWAN R.O.C.

圖 號：
DAC-1545-1