

6

5

4

3

2

1

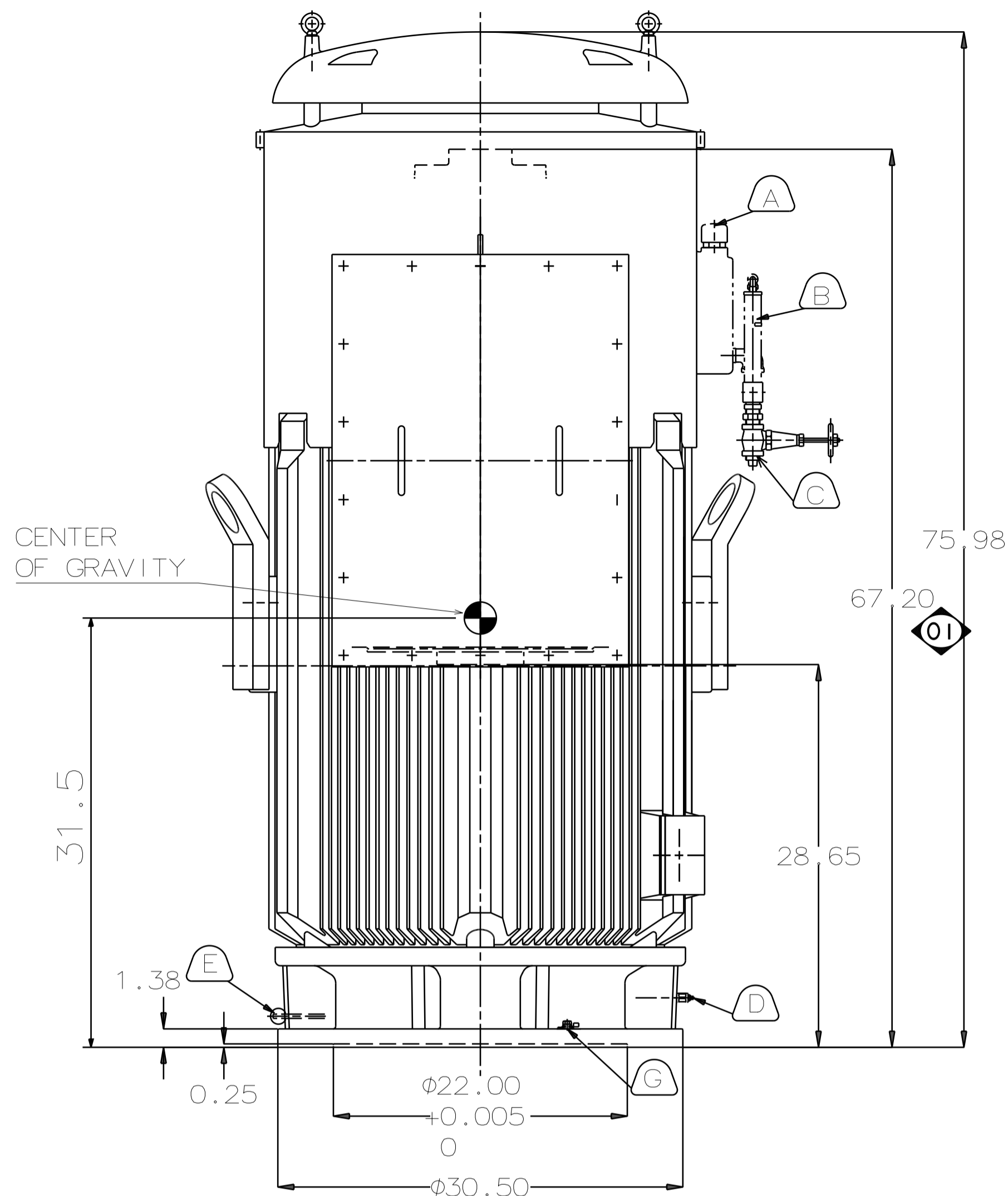

TYPE	OUTPUT		POLE	TIME RATING	VOLTAGE V	Hz	SYN. SPEED R.P.M
	HP.	kW.					
AEEHNNH	600	447.4	4	CONT	460	60	1800

TOTALLY ENCLOSED FAN-COOLED VERTICAL HOLLOW SHAFT TYPE, SQUIRREL CAGE ROTOR

NOTE:

1. DIMENSIONS IN INCH
2. FRAME NO.5810
3. F CLASS INSULATION, S.F.: 1.15
4. FOR DIRECT COUPLING.
5. BEARING SIZE:  
UPPER BEARING: 7328B [INSULATED]  
LOWER BEARING: 6320C3 [UNINSULATED]
6. UPPER BEARING IS INSULATED. ANY METAL CONNECTIONS TO IT MUST BE INSULATED.
7. LUBRICATION:  
UPPER BEARING USE OIL.  
OIL VISCOSITY: ISO VG68 [300SSU AT 100 °F]  
OIL QUANTITY: 3.4 GAL  
LOWER BEARING USE GREASE. [MOBIL POLYREX EM]
8. ROTATION: COUNTER-CLOCKWISE [VIEW FROM TOP].
9. WITH NON-REVERSE RATCHET MECHANISM.
10. WITH GIB KEY:0.625X0.625X3.07,1PCS
11. APPROXIMATE WEIGHT: 6870
12. REED FREQUENCY: 39 HZ
13. DOWNTHRUST: 9,900 LBS (L10-8800HRS)
14. SPACE HEATER RATED AT 120 VOLT, SINGLE PHASE, 218 WATTS, LEADS TERMINATE IN MAIN LEAD BOX.

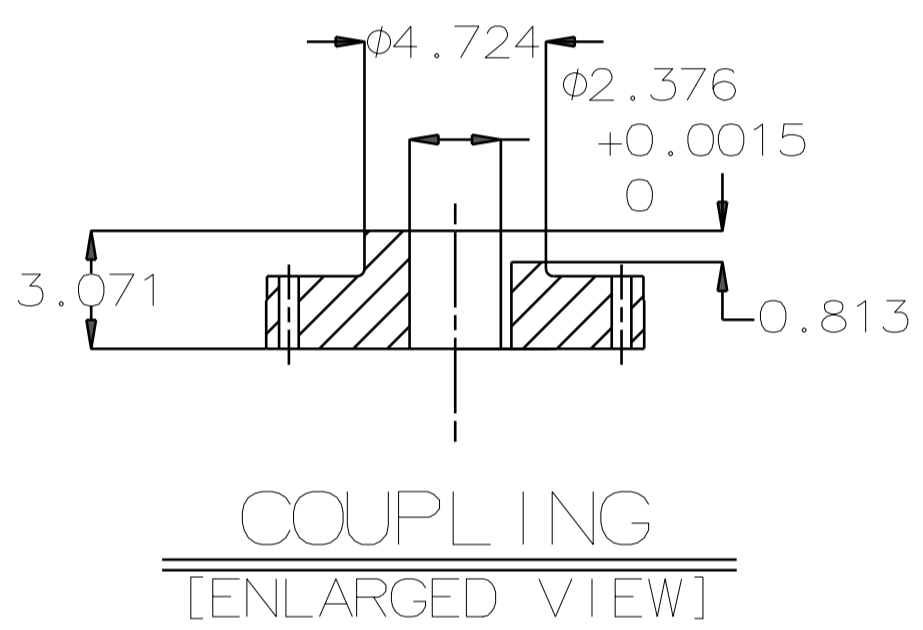
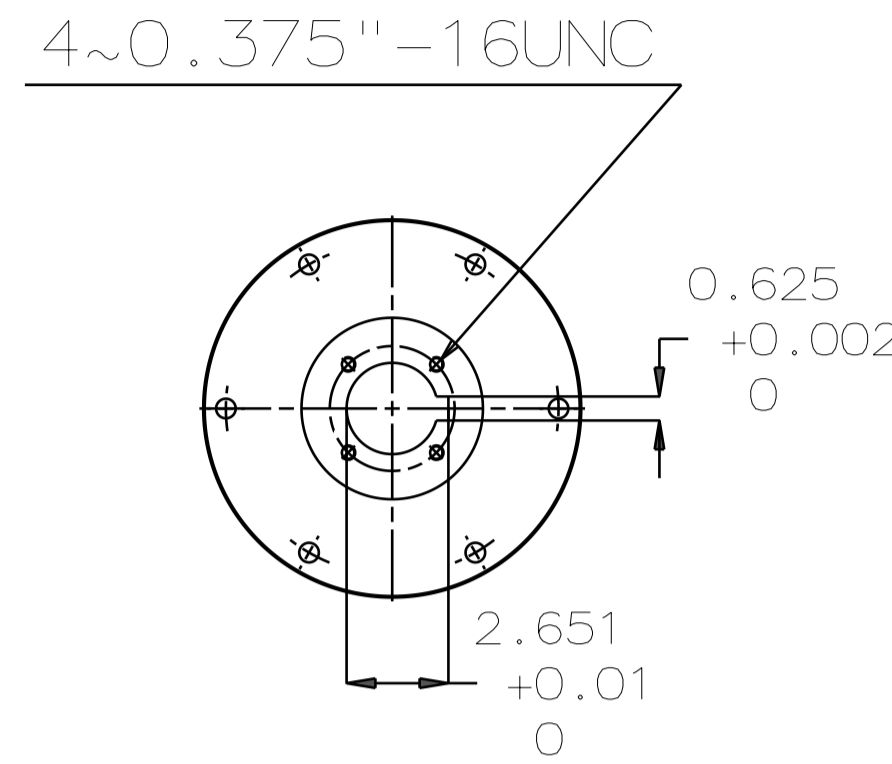

COUPLING [ENLARGED VIEW]

- (A) OIL FILLER [UPPER BEARING]
- (B) OIL GAUGE [UPPER BEARING]
- (C) OIL DRAIN [UPPER BEARING]
- (D) GREASE INLET [LOWER BEARING]
- (E) GREASE DISCHARGER [LOWER BEARING]
- (F) 2~M20 VERTICAL JACKING HOLES, 180°APART IN MOTOR BASE.
- (G) M10 TAPPED HOLE IN MOTOR BASE WITH GROUNDING TERMINAL [R38-10] & BOLT LOCATED AS SHOWN.

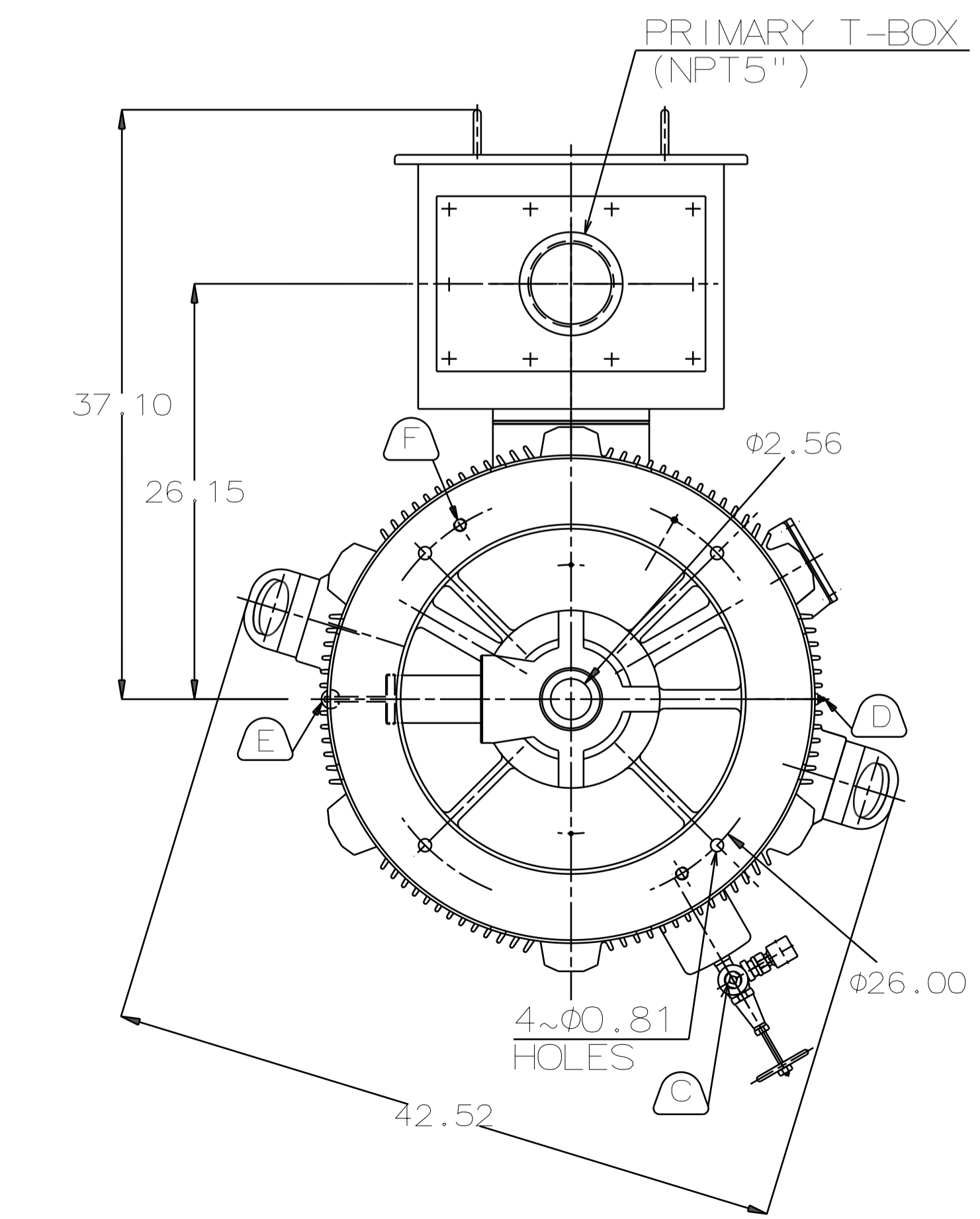

DATE DEC 08 2016	OUTLINE DIMENSIONS	
VHTP6004	3-PHASE INDUCTION MOTOR	
DWG NO. 4B040L125	REV:01	

DWN.	C.FU	APR.17.2015
CHKD.	R.LEE	APR.17.2015
APPD.	C.LIU	APR.17.2015

TECO Westinghouse

6

5

4

3

2

1

ISSUED	<h1>PERFORMANCE DATA</h1> <b>HIGH THRUST HOLLOWSHAFT PUMP MOTORS</b> <b>LOW VOLTAGE SQUIRREL CAGE</b>	MODEL
APR. 20 2015		AEEHNNH
REVISED		
OCT. 21 2016		



TEFC, NEMA DESIGN B, CODE G, CLASS F, 40°C AMBIENT,  
CONTINUOUS DUTY, 1.15 S.F. 460V, 575V 60HZ

## TYPICAL PERFORMANCE (460V)

HP	FULL LOAD RPM	FRAME SIZE (EGV)	EFFICIENCY				POWER FACTOR			CURRENT		TORQUE			ROTOR WR <sup>2</sup> lb-ft <sup>2</sup>	DOWN THRUST LBS	APPROX. ROTOR WEIGHT LBS	APPROX. WEIGHT LBS	REED FREQ. HZ
			FULL LOAD %		3/4 LOAD	1/2 LOAD	FULL LOAD %	3/4 LOAD %	1/2 LOAD %	FULL LOAD A	LOCKED ROTOR A	FULL LOAD lb-ft	LOCKED ROTOR %FLT	BREAK-DOWN %FLT					
			NOM.	MIN.	NOM.	NOM.	%	%	%	A	A	lb-ft	%FLT	%FLT					
200	889	5007	94.5	93.6	94.5	94.2	80.0	75.0	65.0	247	1450	1181.8	90	200	200	13600	1030	3620	37
250	889	5009	95.0	94.1	95.0	94.7	81.0	76.0	66.0	303	1825	1477.3	90	200	262	13600	1260	4410	33
300	1190	5009	95.8	95.0	95.7	95.3	84.8	79.8	69.8	345	2200	1324.3	120	200	252	12400	1120	4600	32
	889	5808	95.0	94.1	95.0	94.7	74.0	69.0	59.0	399	2200	1772.7	90	200	262	22500	1290	5070	50
350	1788	5009	96.2	95.4	96.1	95.7	86.3	81.3	71.3	394	2550	1028.3	120	200	165	10800	980	4210	34
	1190	5808	95.8	95.0	95.7	95.3	80.6	75.6	65.6	424	2550	1545.1	120	200	285	20400	1270	5510	48
	889	5808	95.0	94.1	95.0	94.7	76.0	71.0	61.0	453	2550	2068.2	90	200	327	22500	1430	5620	47
400	1788	5009	96.2	95.4	96.1	95.7	86.6	81.6	71.6	449	2900	1175.2	120	200	182	10800	1050	4410	33
	1190	5808	95.8	95.0	95.7	95.3	80.9	75.9	65.9	482	2900	1765.8	120	200	307	20400	1320	5890	46
	889	5808	95.0	94.1	95.0	94.7	76.0	71.0	61.0	518	2900	2363.6	90	200	378	22500	1540	5830	47
450	1788	5808	96.2	95.4	96.1	95.7	84.0	79.0	69.0	521	3250	1322.1	110	200	226	10100	1200	5660	47
	1190	5808	95.8	95.0	95.7	95.3	80.2	75.2	65.2	547	3250	1986.5	120	200	329	20400	1370	5930	46
	889	5808	95.0	94.1	95.0	94.7	76.0	71.0	61.0	583	3250	2659.1	90	200	429	22500	1640	6440	45
500	1788	5808	96.2	95.4	96.1	95.7	84.0	79.0	69.0	578	3625	1469.0	110	200	249	10100	1270	5900	46
	1190	5808	95.8	95.0	95.7	95.3	81.2	76.2	66.2	601	3625	2207.2	120	200	365	20400	1450	6020	46
	889	5808	95.0	94.1	95.0	94.7	76.0	71.0	61.0	647	3625	2954.5	90	200	472	22500	1710	6790	44
600	1788	5810	96.2	95.4	96.1	95.7	84.0	79.0	69.0	694	4744	1762.8	120	210	291	10100	1330	6680	40
	1190	5810	95.8	95.0	95.7	95.3	81.7	76.7	66.7	717	4744	2648.7	120	200	438	20400	1720	6810	39
700	1788	5810	96.2	95.4	96.1	95.7	85.0	80.0	70.0	800	5535	2056.6	120	200	344	10100	1470	7200	38
	1190	5810	95.8	95.0	95.7	95.3	81.3	76.3	66.3	840	5535	3090.1	120	200	489	20400	1840	7230	38
800	1788	5810	96.2	95.4	96.1	95.7	86.0	81.0	71.0	904	6326	2350.4	120	200	385	10100	1580	7620	37

NOTE : 1. THE ABOVE ARE TYPICAL VALUES BASED ON TEST ACCORDING TO ANSI/IEEE STANDARD 112 METHOD B.

- BREAKDOWN & LOCKED ROTOR TORQUES ARE SHOWN AS AVERAGE EXPECTED VALUES.
- EFFICIENCY, POWER FACTOR, SPEED AND TORQUE ARE THE SAME FOR OTHER VOLTAGES. CURRENT VALUES VARY INVERSELY WITH VOLTAGE.

- DECLARED EFFICIENCY HAVN'T TAKEN INTO ACCOUNT OF THRUST LOAD LOSSES
- TOLERANCE ACCORDING TO NEMA MG1-12& IEC 34-1
- THRUST LOAD LOSSES ESTIMATED OF ANGULAR CONTACT BALL BEARING AS FOLLOWS : (ACCORDING TO NEMA STANDARD MG1-12.7)

FRAME SIZE	LOSS HP/100 RPM RPM /1000 LB THRUST
5007-5810	0.0208

- REDUCING THE THRUST LOAD WILL INCREASE BEARING LIFE AS FOLLOWS :

ANGULAR CONTACT BALL BEARING	THRUST(%)	100	80	71	60	52
	BEARING LIFE(Hrs.)	8800	15000	20000	30000	40000
SPHERICAL ROLLER THRUST BEARING	THRUST(%)	100	84	75	64	58
	BEARING LIFE(Hrs.)	30000	50000	70000	110000	150000

- DATA SUBJECT TO CHANGE WITHOUT NOTICE

APPD.	M.Y.HSU	JUN. 16 2016	<b>TECO Electric &amp; Machinery Co., Ltd.</b>	DWG NO.	<b>3A057M061E</b>
CHKD.	H.Y.WANG	JUN. 16 2016		REV.01	
DWN.	M.H.KUO	JUN. 16 2016		1/1	

6 5 4 3 2 1

D  
C  
B  
A

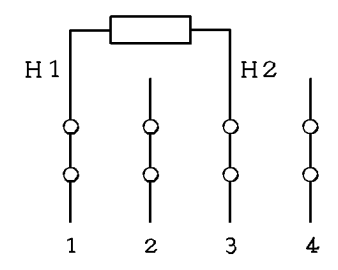
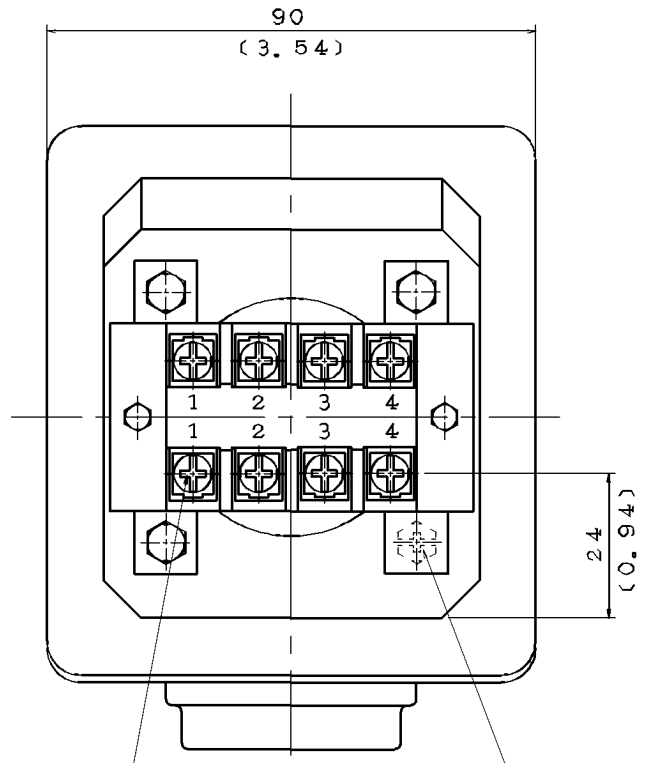
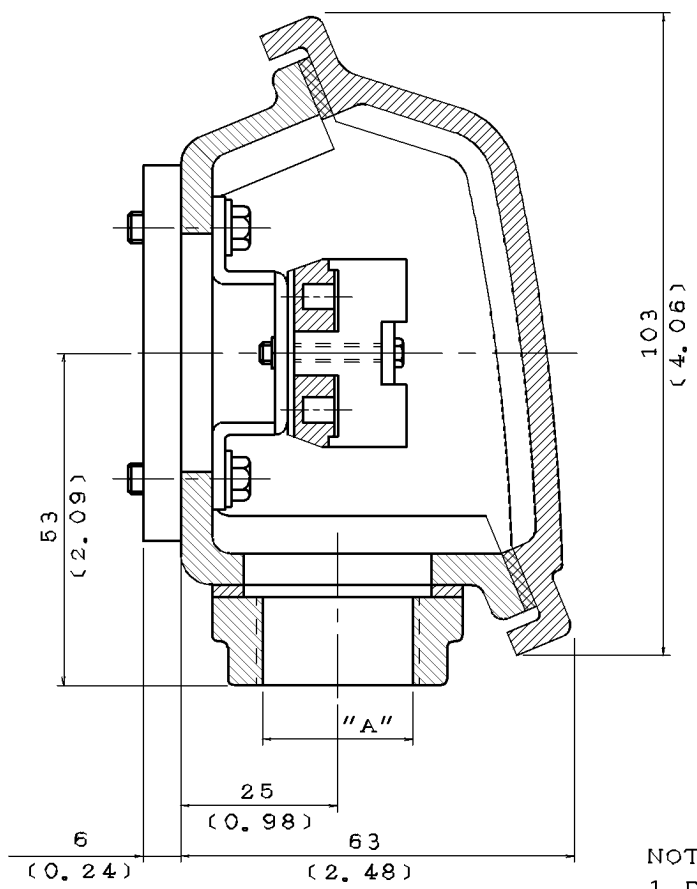

M4 SCREW FOR CONNECTION

M5 EARTH BOLT

- NOTE:
1. DIMENSIONS IN mm (inch)
  2. TW-06
  3. SPACE HEATER T-BOX.
  4. ENCLOSURE: IP55
  5. MATERIAL: CAST IRON

ITEM	A
01	M20×1.5
02	PF-0.5"
03	PF-0.75"
04	PT-0.5"
05	PT-0.75"
06	NPT-0.5"
07	NPT-0.75"
08	M25×1.5
09	PF1"
10	NPT1"
11	PG16

DATE \_\_\_\_\_ SCHEMATIC DRAWING

TERMINAL BOX

DWN.	H. HUANG	JUN 19 200
CHKD.	H. HUANG	JUN 19 200
APPD.	C. WANG	JUN 19 200

**TECO** Westinghouse

DWG NO. 3A040U272 REV:09

6 5 4 3 2 1

**TECO**

# CONNECTION DIAGRAM

MODEL

DATE :  
DEC.04.'02

For  $\Delta/\Delta$  connection

DAC-1545-1

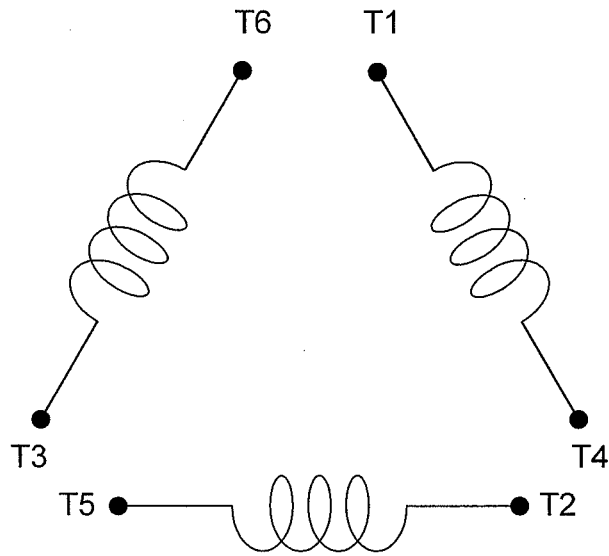

SCHMATIC -  $\Delta/\Delta$  CONNECTION

## ROTATION

(VIEWED FROM DRIVE END)

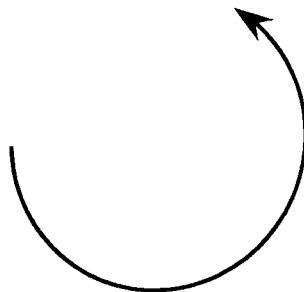

## CONNECTION

$\Delta-\Delta$  START

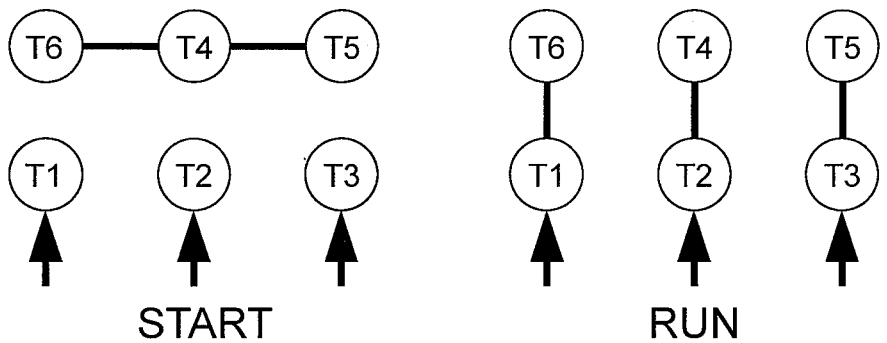

ACROSS-THE-LINE

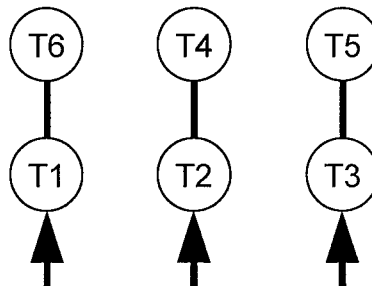

承 認		
審 核	蔡	Dec.05.02
校 對	林	Dec.04.02
繪 製	林賢龍	DEC,04,'02

**東元電機股份有限公司**  
**TECO ELECTRIC & MACHINERY CO., LTD.**  
 TAIWAN R.O.C.

圖 號：  
**DAC-1545-1**