

**BALDOR® • RELIANCE** 

**Product Information Packet**

**VXT3022T-5**

**2HP,3450RPM,3PH,60HZ,143TC,0532M,TEFC,F1**

Part Detail							
Revision:	-	Status:	PRD/A	Change #:		Proprietary:	No
Type:	AC	Elec. Spec:	05WGW062	CD Diagram:	CD0006	Mfg Plant:	
Mech. Spec:		Layout:	05LY-000-374	Poles:	02	Created Date:	05-25-2021
Base:		Eff. Date:	07-09-2021	Leads:	3#18		

Specs			
Catalog Number:	VXT3022T-5	Feedback Device:	NO FEEDBACK
Enclosure:	TEFC	Heater Indicator:	No Heater
Frame:	143TC	Insulation Class:	F
Frame Material:	Iron	Inverter Code:	Inverter Duty
Output @ Frequency:	2.000 HP @ 60 HZ	IP Rating:	NONE
Synchronous Speed @ Frequency:	3600 RPM @ 60 HZ	KVA Code:	N
Voltage @ Frequency:	575.0 V @ 60 HZ	Lifting Lugs:	No Lifting Lugs
XP Class and Group:	CLI GP A,B,C,D	Locked Bearing Indicator:	Locked Bearing
XP Division:	Division II	Motor Lead Termination:	Flying Leads
Agency Approvals:	CSA EEV	Motor Type:	0532M
	NEMA PREMIUM	Mounting Arrangement:	F1
	NEMA_PREMIUM	Power Factor:	85
	UR	Product Family:	General Purpose
	CCSA US	Pulley Face Code:	C-Face
Auxillary Box:	No Auxillary Box	Rodent Screen:	None
Auxillary Box Lead Termination:	None	Shaft Ground Indicator:	No Shaft Grounding
Base Indicator:	No Mounting	Shaft Rotation:	Reversible
Bearing Grease Type:	Polyrex EM (-20F +300F)	Speed Code:	Single Speed

<b>Blower:</b>	None	<b>Motor Standards:</b>	NEMA
<b>Constant Torque Speed Range:</b>	6	<b>Starting Method:</b>	Direct on line
<b>Current @ Voltage:</b>	2.000 A @ 575.0 V	<b>Thermal Device - Bearing:</b>	None
<b>Design Code:</b>	B	<b>Thermal Device - Winding:</b>	None
<b>Drip Cover:</b>	No Drip Cover	<b>Vibration Sensor Indicator:</b>	No Vibration Sensor
<b>Duty Rating:</b>	CONT	<b>Winding Thermal 1:</b>	None
<b>Electrically Isolated Bearing:</b>	Not Electrically Isolated	<b>Winding Thermal 2:</b>	None
		<b>XP Temp Code:</b>	T4

Nameplate NP4224L			
CAT.NO.	VXT3022T-5	I.P.	54
SPEC.	05-0000-0999	ENCL	TEFC
FRAME	143TC	H.P.	2
VOLTS	575	P.F.	85
F.L. AMPS	2	RATING	40C AMB-CONT
R.P.M.	3450	USABLE AT 208V	
HZ.	60	PH.	3
SER.F.	1.00	DES.	B
NEMA NOM. EFF.	86.5	WV	0.09
DE	6205	ODE	6203
MAG. CUR.	.9	SL HZ	1.7
INV TYPE	PWM	CHP	60
CT	6	TO	60
CC	010A	VT	6
		TO	60
		SN	
	1.15 SF ON SINE WAVE		
		INV TEMP CODE	T4

Parts List		
Part Number	Description	Quantity
SA395243	SA 05-0000-0999	1.000 EA
RA385974	RA 05-0000-0999	1.000 EA
LB1119N	WARNING LABEL	1.000 EA
LC0006	CONNECTION LABEL	1.000 EA
LB1449	DIV-2/NEC WARNING LABEL	1.000 EA
PK3082	STYROFOAM CRADLE	1.000 EA
NP4224L	SS CP INV DIV-2 UL CSA-C US EEV PREM, DI	1.000 EA
85XU0407S04	4X1/4 U DRIVE PIN STAINLESS	2.000 EA
MN416A01	TAG-INSTAL-MAINT no wire (2100/bx) 4/22	1.000 EA
35FH4005A32SP	IEC FH NO GRSR W/3 HOLES - PRIMED	1.000 EA
51XW1032A06	10-32 X .38, TAPTITE II, HEX WSHR SLTD S	3.000 EA
34FN3002B01	EXTERNAL FAN, PLASTIC, .637/.639 HUB W/	1.000 EA
51XB0818A12	8-18X3/4 HXWSSLD SERTYB	1.000 EA
MJ1000A02	GREASE, MOBIL POLYREX EM - 124047	0.050 LB
HA3100A47	THRUBOLT 10-32 X 7.625	4.000 EA
35EP3122K00	MASTER ODE,203 BRG,.683SH,#26 DRN,FH MTG	1.000 EA
HW4600B39SP	V-RING SLINGER 0.550 X 0.790 X .18 VITON	1.000 EA
HW5100A03	WAVY WASHER (W1543-017)	1.000 EA
HA4067A01	PUSH IN DRAIN FITTING (BLACK)	1.000 EA
35EP3307F11	F00 W/SLINGER	1.000 EA
HW4600B32SP	V-RING SLINGER 1.000 X 1.540 X .24 VITON	1.000 EA
51XN1032A20	10-32 X 1 1/4 HX WS SL SR	2.000 EA
HA4067A01	PUSH IN DRAIN FITTING (BLACK)	1.000 EA
06CB3000	BALDOR CONDUIT BOX CAST	1.000 EA

<b>Parts List (continued)</b>		
<b>Part Number</b>	<b>Description</b>	<b>Quantity</b>
06GS1000	GASKET,CONDUIT BOX	1.000 EA
51XW2520A12	SCREW, HEX SER SLT HD, ZN, 1/4-20 X .75	2.000 EA
11XW1032G06	10-32 X .38, TAPTITE II, HEX WSHR SLTD U	1.000 EA
HW3001B02	BRASS CUP WASHER W/GROUND SYMBOL TAB,	1.000 EA
06CB3500	BALDOR CONDUIT BOX LID	1.000 EA
06GS1001	BALDOR CONDUIT BOX GASKET	1.000 EA
51XW2520A12	.25-20 X .75, TAPTITE II, HEX WSHR SLTD	2.000 EA
MG1025L14	WILKOFAS, 776.14, GRUNDFOS BLACK	0.125 GA
36PA1000	PKG GRP, PRINT PK1016A06	1.000 EA
HW2501D13	KEY, 3/16 SQ X 1.375	1.000 EA
HA7000A01	KEY RETAINER 7/8" DIA SHAFT	1.000 EA
FE-0000001	ZRTG FE ASSEMBLY	1.000 EA

**AC Induction Motor Performance Data**

Record # 40

Typical performance - not guaranteed values

Winding: 05WGW062-R001		Type: 0532M	Enclosure: TEFC	
<b>Nameplate Data</b>			<b>575 V, 60 Hz: Single Voltage Motor</b>	
Rated Output (HP)	2	Full Load Torque	3 LB-FT	
Volts	575	Start Configuration	direct on line	
Full Load Amps	2	Breakdown Torque	16 LB-FT	
R.P.M.	3450	Pull-up Torque	12.5 LB-FT	
Hz	60 Phase	Locked-rotor Torque	16 LB-FT	
NEMA Design Code	B KVA Code	Starting Current	24 A	
Service Factor (S.F.)	1.15	No-load Current	0.86 A	
NEMA Nom. Eff.	86.5 Power Factor	Line-line Res. @ 25°C	8.58 Ω	
Rating - Duty	40C AMB-CONT	Temp. Rise @ Rated Load	31°C	
S.F. Amps		Temp. Rise @ S.F. Load	36°C	

**Load Characteristics 575 V, 60 Hz, 2 HP**

% of Rated Load	25	50	75	100	125	150	S.F.
Power Factor	50	70	80	85	88	89	87
Efficiency	75.2	83.8	86.2	86.7	86.4	85.5	86.5
Speed	3571	3548	3525	3501	3476	3448	3486
Line amperes	1.02	1.32	1.67	2.04	2.46	2.91	2.3

Performance Graph at 575V, 60Hz, 2.0HP Typical performance - Not guaranteed values

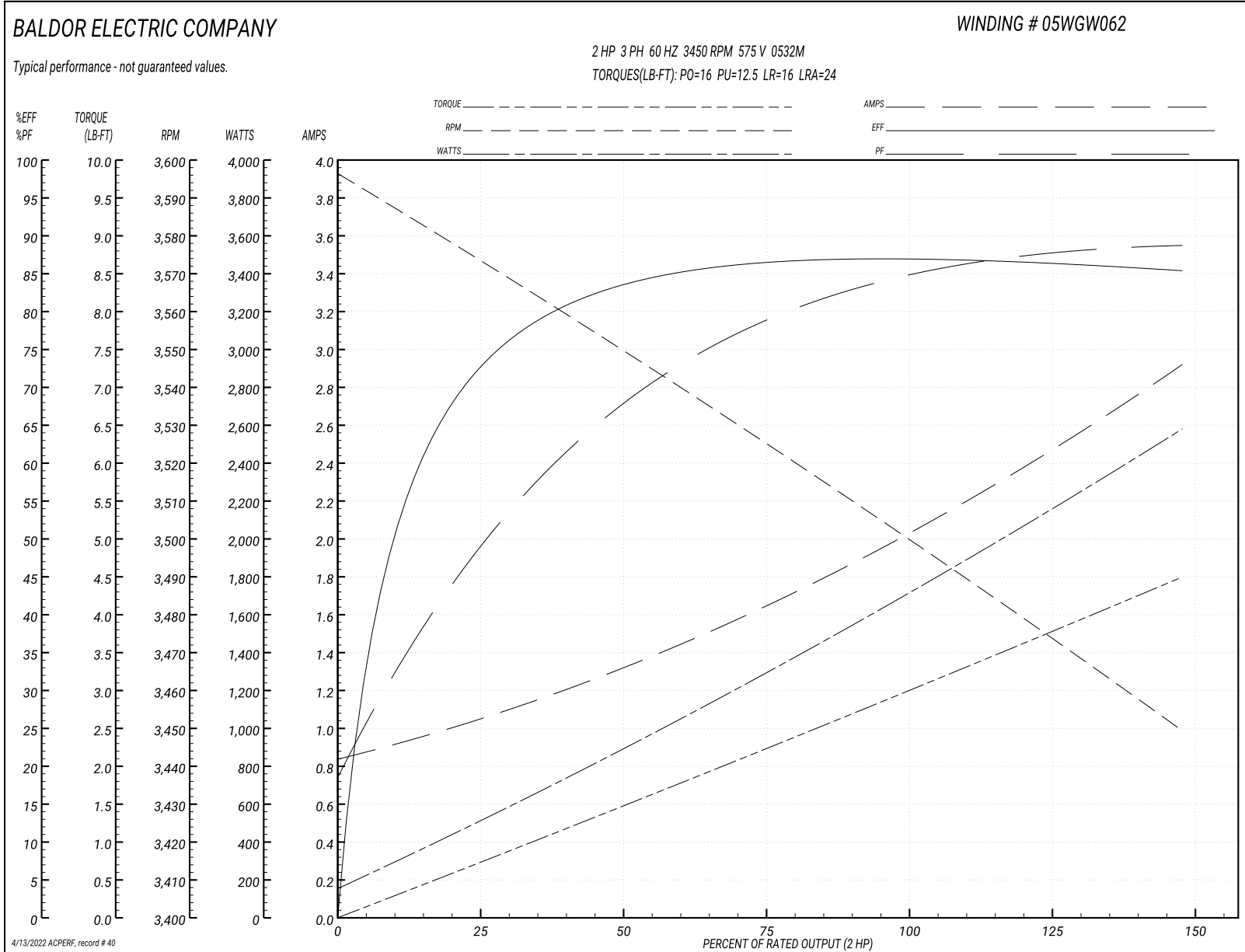



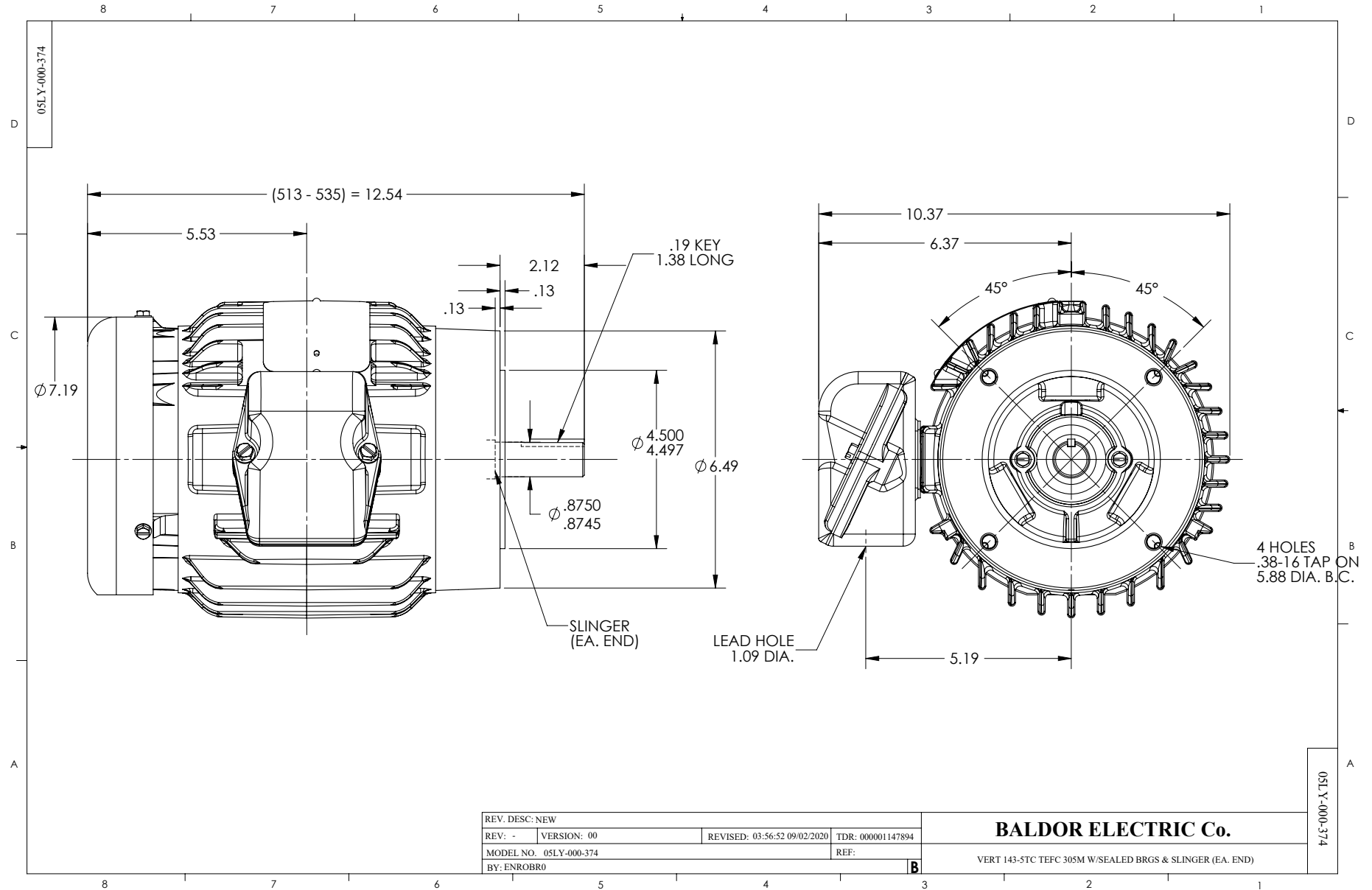

CD0006



NOTES:

1. THREE LEAD MOTOR MAY BE EITHER WYE CONNECTED OR DELTA CONNECTED.
2. INTERCHANGE ANY TWO LINE LEADS TO REVERSE ROTATION.
3. OPTIONAL THERMOSTATS ARE PROVIDED WHEN SPECIFIED.
4. ACTUAL NUMBER OF INTERNAL PARALLEL CIRCUITS MAY VARY.
5. LEAD COLORS ARE OPTIONAL. LEADS MUST BE NUMBERED AS SHOWN.

CD0006

REV. DESC: ADD CLASS CONN00000007		
REV. LTR: E	VERSION: 01	TDR: 000001099922
FILE: \AAA\00005\141	REVISED: 10:24:49 02/19/2019	BY: ENBRIRO
MTL: -		

**BALDOR - RELIANCE®**

3PH, SV, 3 LEADS, WYE OR DELTA CONNECTED

SH 1 of 1

Marketing maintained PDF of MN416:

<http://www.baldor.com/support/Literature/Load.ashx/MN416?ManNumber=MN416>