

BALDOR® • RELIANCE 

Product Information Packet

VXT3034T

3HP,1755RPM,3PH,60HZ,182TC,0632M,TEFC,F1

Part Detail							
Revision:	-	Status:	PRD/A	Change #:		Proprietary:	No
Type:	AC	Elec. Spec:	06WGX181	CD Diagram:	CD0005	Mfg Plant:	
Mech. Spec:		Layout:	06LYH799	Poles:	04	Created Date:	11-19-2020
Base:		Eff. Date:	12-17-2020	Leads:	9#16		

Specs			
Catalog Number:	VXT3034T	Electrically Isolated Bearing:	Not Electrically Isolated
Enclosure:	TEFC	Feedback Device:	NO FEEDBACK
Frame:	182TC	Heater Indicator:	No Heater
Frame Material:	Iron	Insulation Class:	F
Output @ Frequency:	3.000 HP @ 60 HZ	Inverter Code:	Inverter Duty
Synchronous Speed @ Frequency:	1800 RPM @ 60 HZ	IP Rating:	NONE
Voltage @ Frequency:	460.0 V @ 60 HZ	KVA Code:	J
	230.0 V @ 60 HZ	Lifting Lugs:	Standard Lifting Lugs
	208.0 V @ 60 HZ	Locked Bearing Indicator:	Locked Bearing
XP Class and Group:	CLI GP A,B,C,D	Motor Lead Termination:	Flying Leads
XP Division:	Division II	Motor Type:	0632M
Agency Approvals:	CCSA US	Mounting Arrangement:	F1
	CSA EEV	Power Factor:	77
	NEMA PREMIUM	Product Family:	General Purpose
	UR	Pulley Face Code:	C-Face
Auxillary Box:	No Auxillary Box	Rodent Screen:	None
Auxillary Box Lead Termination:	None	Shaft Ground Indicator:	No Shaft Grounding
Base Indicator:	No Mounting	Shaft Rotation:	Reversible

Bearing Grease Type:	Polyrex EM (-20F +300F)	Speed Code:	Single Speed
Blower:	None	Motor Standards:	NEMA
Constant Torque Speed Range:	3	Starting Method:	Direct on line
Current @ Voltage:	8.600 A @ 208.0 V	Thermal Device - Bearing:	None
	8.200 A @ 230.0 V	Thermal Device - Winding:	None
	4.100 A @ 460.0 V	Vibration Sensor Indicator:	No Vibration Sensor
Design Code:	B	Winding Thermal 1:	None
Drip Cover:	No Drip Cover	Winding Thermal 2:	None
Duty Rating:	CONT	XP Temp Code:	T3C

Nameplate NP4163L										
CAT.NO.	VXT3034T					I.P.	54			
SPEC.	06-0000-0797					ENCL	TEFC			
FRAME	182TC				H.P.	3				
VOLTS	208-230/460				P.F.	77				
F.L. AMPS	8.6-8.2/4.1				RATING	40C AMB-CONT				
R.P.M.	1755				USABLE AT 208V					
HZ.	60				PH.	3		CLASS	F	
SER.F.	1.15				DES.	B		SL HZ	1.5	
NEMA NOM. EFF.	89.5				Wk2	0.3				
DE	6206				ODE	6205				
MAG. CUR.	4.2/2.1									
INV TYPE	PWM		CHP	60		TO	90		T. CODE	T3C
CT	3		TO	60		VT	3		TO	60
CC	010A			SN						
USABLE AT 50 HZ 2.5HP 190/380V										
8.2/4.1A										

Parts List		
Part Number	Description	Quantity
SA388655	SA 06-0000-0797	1.000 EA
RA379020	RA 06-0000-0797	1.000 EA
LB1115N	LABEL,LIFTING DEVICE (ON ROLLS)	1.000 EA
LC0005E01	CONN.DIA./WARNING LABEL (LC0005/LB1119N)	1.000 EA
LB1449	DIV-2/NEC WARNING LABEL	1.000 EA
PK3082	STYROFOAM CRADLE	1.000 EA
NP4163L	SS CP INV DIV-2 UL CSA-C US EEV PREM, DI	1.000 EA
85XU0407S04	4X1/4 U DRIVE PIN STAINLESS	2.000 EA
MN416A01	TAG-INSTAL-MAINT no wire (2100/bx) 4/22	1.000 EA
HW3201A05	3/8-16 EYEBOLT	1.000 EA
36FH4009A101	IEC FH NO GREASER, W/PRIMER	1.000 EA
51XW1032A06	10-32 X .38, TAPTITE II, HEX WSHR SLTD S	3.000 EA
34FN3002A02	EXTERNAL FAN, PLASTIC, .905/.907 HUB W/	1.000 EA
51XB0818A12	8-18X3/4 HXWSSLD SERTYB	1.000 EA
MJ1000A02	GREASE, MOBIL POLYREX EM - 124047	0.050 LB
HA3101A34	THRUBOLT- 1/4-20 X 10.375	4.000 EA
36EP3104B47	FREP MACH W/O GRSR,RAISED FH PADS,SLING	1.000 EA
HW4600B32SP	V-RING SLINGER 1.000 X 1.540 X .24 VITON	1.000 EA
HW5100A05	WVY WSHR F/205 & 304 BRGS	1.000 EA
HA4067A01	PUSH IN DRAIN FITTING (BLACK)	1.000 EA
36EP3301A34	SPL PU. ENDPLATE - ENCLOSED	1.000 EA
HW4600B36SP	V-RING SLINGER 1.188 X 1.690 X .24 VITON	1.000 EA
10XN2520A28	1/4-20X 1 3/4 HEX HD	4.000 EA
HW1001A25	LOCKWASHER 1/4, ZINC PLT .493 OD, .255 I	4.000 EA

Parts List (continued)		
Part Number	Description	Quantity
HA4067A01	PUSH IN DRAIN FITTING (BLACK)	1.000 EA
06CB3000	BALDOR CONDUIT BOX CAST	1.000 EA
06GS1000	GASKET,CONDUIT BOX	1.000 EA
51XW2520A12	SCREW, HEX SER SLT HD, ZN, 1/4-20 X .75	2.000 EA
11XW1032G06	10-32 X .38, TAPTITE II, HEX WSHR SLTD U	1.000 EA
HW3001B02	BRASS CUP WASHER W/GROUND SYMBOL TAB,	1.000 EA
06CB3500	BALDOR CONDUIT BOX LID	1.000 EA
06GS1001	BALDOR CONDUIT BOX GASKET	1.000 EA
51XW2520A12	.25-20 X .75, TAPTITE II, HEX WSHR SLTD	2.000 EA
MG1025L14	WILKOFASST, 776.14, GRUNDFOS BLACK	0.125 GA
36PA1001	PKG GRP, PRINT PK1017A06	1.000 EA
HW2501E16	KEY, 1/4 SQ X 1.750	1.000 EA
HA7000A02	KEY RETAINER RING, 1 1/8 DIA, 1 3/8 DIA	1.000 EA

AC Induction Motor Performance Data

Record # 46998

Typical performance - not guaranteed values

Winding: 06WGX181-R047		Type: 0632M	Enclosure: TEFC	
Nameplate Data			460 V, 60 Hz: High Voltage Connection	
Rated Output (HP)	3	Full Load Torque	9.06 LB-FT	
Volts	208-230/460	Start Configuration	direct on line	
Full Load Amps	8.6-8.2/4.1	Breakdown Torque	33.1 LB-FT	
R.P.M.	1755	Pull-up Torque	18.2 LB-FT	
Hz	60 Phase	Locked-rotor Torque	20.4 LB-FT	
NEMA Design Code	B KVA Code	Starting Current	29.8 A	
Service Factor (S.F.)	1.15	No-load Current	2.14 A	
NEMA Nom. Eff.	89.5 Power Factor	Line-line Res. @ 25°C	3.92 Ω	
Rating - Duty	40C AMB-CONT	Temp. Rise @ Rated Load	35°C	
S.F. Amps		Temp. Rise @ S.F. Load	42°C	
		Rotor inertia	0.298 LB-FT ²	

Load Characteristics 460 V, 60 Hz, 3 HP

% of Rated Load	25	50	75	100	125	150	S.F.
Power Factor	38	58	70	77	81	83	79
Efficiency	83.6	88.9	90.1	89.9	89.1	87.8	89.4
Speed	1789.5	1779.3	1768.8	1757	1744.4	1730	1749
Line amperes	2.34	2.79	3.39	4.1	4.91	5.86	4.59

Performance Graph at 460V, 60Hz, 3.0HP Typical performance - Not guaranteed values

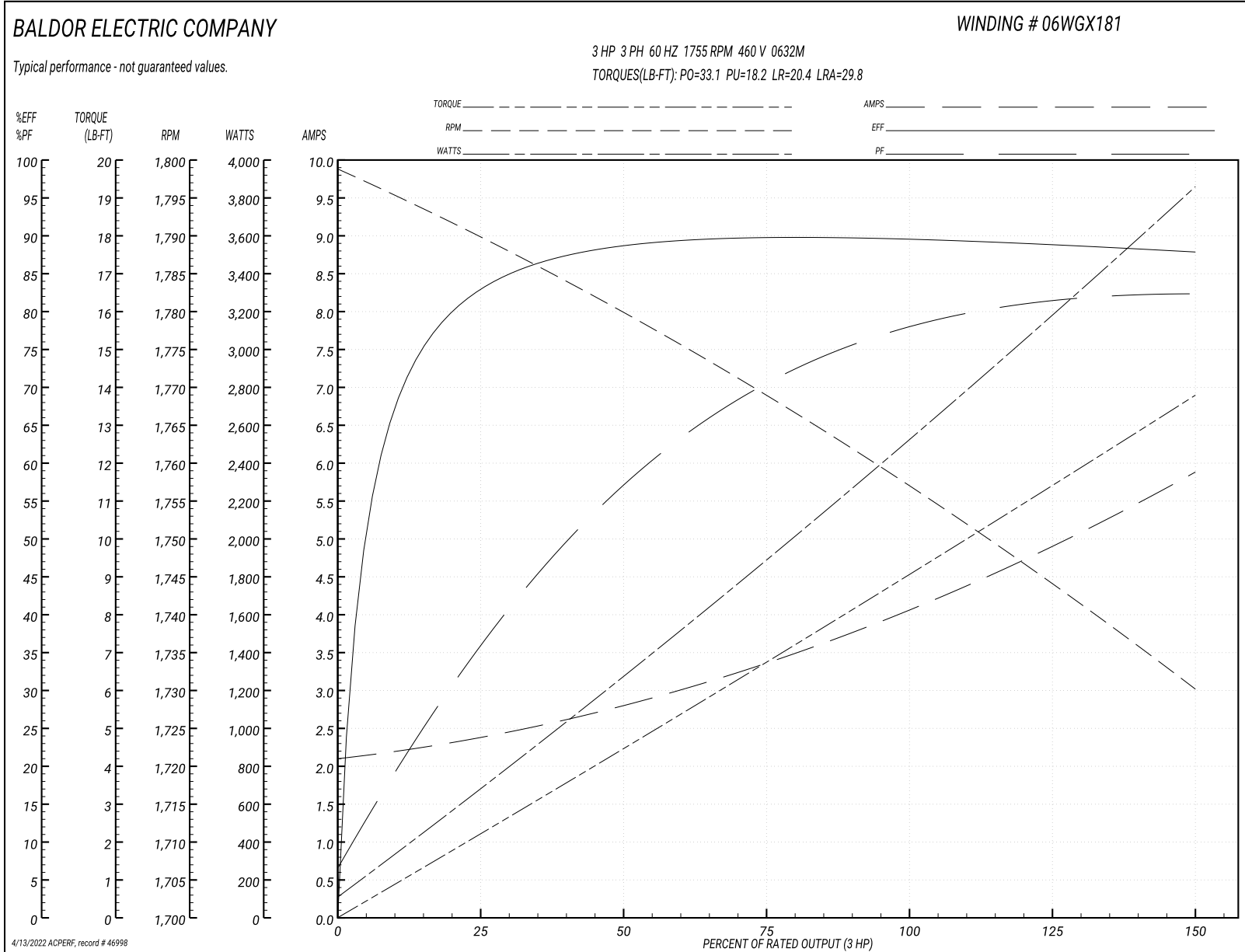

06LYH799

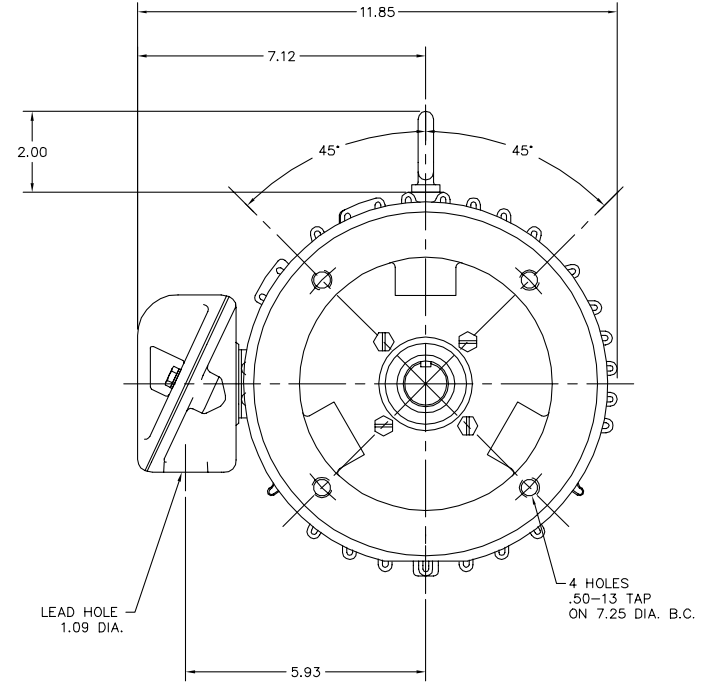
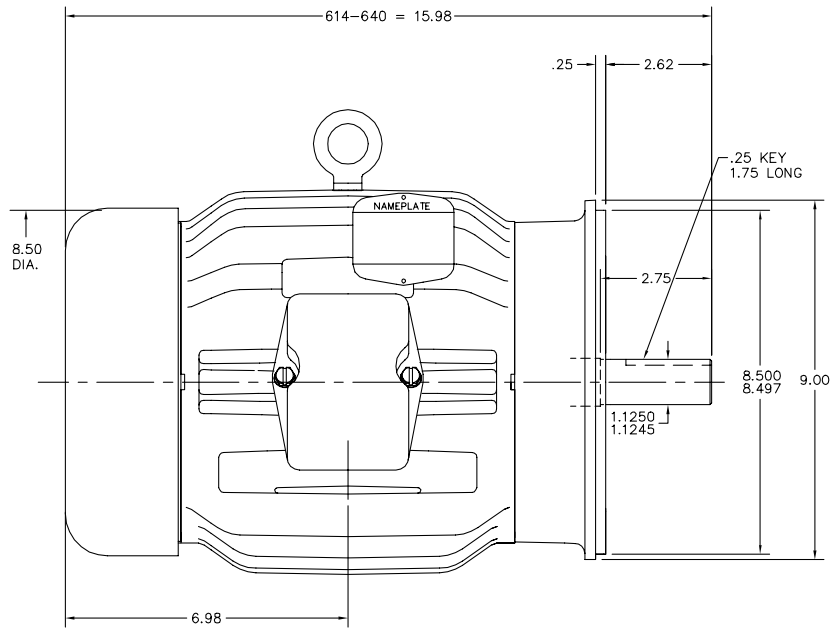

06LYH799

CUSTOMER IS RESPONSIBLE FOR DETERMINING THAT BALDOR'S PRODUCT WILL PERFORM SUITABLY IN THE INTENDED APPLICATION.

REV. DESC: REMOVE GROUND LUG FROM LAYOUT PER PRODUCTION		
REV. LTR: A	VERSION: 01	TDR: 00000116.3096
FILE: \AAA\00139\628	REVISED: 09:51:32 03/17/2021	BY: CKMICRO
MTL: -		

BALDOR - RELIANCE®

VERT 182-4TC TEFC W/SEALED BRGS
SH 1 of 1

CD0005



LOW VOLTAGE
(2Y)



LINE

HIGH VOLTAGE
(1Y)



LINE

NOTES:

1. INTERCHANGE ANY TWO LINE LEADS TO REVERSE ROTATION.
2. OPTIONAL THERMOSTATS ARE PROVIDED WHEN SPECIFIED.
3. ACTUAL NUMBER OF INTERNAL PARALLEL CIRCUITS MAY BE A MULTIPLE OF THOSE SHOWN ABOVE.
4. LEAD COLORS ARE OPTIONAL. LEADS MUST ALWAYS BE NUMBERED AS SHOWN.

REV. DESC: REVISE TO SHOW OPTIONAL COLORS			
REV. LTR: E	BY: JLP	REVISED: 01/19/99 10:15	TDR: 0171435
900000		FILE: AAA00005140	MDL: -
		MTL: -	

BALDOR ELECTRIC Co.

3PH, DV, 9 LEADS

CD0005

Marketing maintained PDF of MN416:

<http://www.baldor.com/support/Literature/Load.ashx/MN416?ManNumber=MN416>