

BALDOR® • RELIANCE 

Product Information Packet

VXT3054T-5

5HP,1750RPM,3PH,60HZ,184TC,0642M,TEFC,F1

Part Detail							
Revision:	-	Status:	PRD/A	Change #:		Proprietary:	No
Type:	AC	Elec. Spec:	06WGY425	CD Diagram:	CD0006	Mfg Plant:	
Mech. Spec:		Layout:	06LYH799	Poles:	04	Created Date:	05-20-2021
Base:		Eff. Date:	07-26-2021	Leads:	3#16		

Specs			
Catalog Number:	VXT3054T-5	Feedback Device:	NO FEEDBACK
Enclosure:	TEFC	Heater Indicator:	No Heater
Frame:	184TC	Insulation Class:	F
Frame Material:	Iron	Inverter Code:	Inverter Duty
Output @ Frequency:	5.000 HP @ 60 HZ	IP Rating:	NONE
Synchronous Speed @ Frequency:	1800 RPM @ 60 HZ	KVA Code:	H
Voltage @ Frequency:	575.0 V @ 60 HZ	Lifting Lugs:	Standard Lifting Lugs
XP Class and Group:	CLI GP A,B,C,D	Locked Bearing Indicator:	Locked Bearing
XP Division:	Division II	Motor Lead Termination:	Flying Leads
Agency Approvals:	CSA EEV	Motor Type:	0642M
	NEMA PREMIUM	Mounting Arrangement:	F1
	NEMA_PREMIUM	Power Factor:	81
	UR	Product Family:	General Purpose
	CCSA US	Pulley Face Code:	C-Face
Auxillary Box:	No Auxillary Box	Rodent Screen:	None
Auxillary Box Lead Termination:	None	Shaft Ground Indicator:	No Shaft Grounding
Base Indicator:	No Mounting	Shaft Rotation:	Reversible
Bearing Grease Type:	Polyrex EM (-20F +300F)	Speed Code:	Single Speed

Blower:	None	Motor Standards:	NEMA
Constant Torque Speed Range:	6	Starting Method:	Direct on line
Current @ Voltage:	5.300 A @ 575.0 V	Thermal Device - Bearing:	None
Design Code:	B	Thermal Device - Winding:	None
Drip Cover:	No Drip Cover	Vibration Sensor Indicator:	No Vibration Sensor
Duty Rating:	CONT	Winding Thermal 1:	None
Electrically Isolated Bearing:	Not Electrically Isolated	Winding Thermal 2:	None
		XP Temp Code:	T3C

Nameplate NP4224L										
CAT.NO.	VXT3054T-5						I.P.	54		
SPEC.	06-0000-0944						ENCL	TEFC		
FRAME	184TC		H.P.	5		T. CODE	T3C			
VOLTS	575			P.F.	81					
F.L. AMPS	5.3			RATING	40C AMB-CONT					
R.P.M.	1750			USABLE AT 208V						
HZ.	60			PH.	3		CLASS	F		
SER.F.	1.15			DES.	B		SL HZ	1.7		
NEMA NOM. EFF.	89.5			Wk2	0.39					
DE	6206			ODE	6205					
MAG. CUR.	2.2									
INV TYPE	PWM		CHP	60		TO	90		INV TEMP CODE	T3C
CT	6		TO	60		VT	6		TO	60
CC	010A		SN							

Parts List		
Part Number	Description	Quantity
SA395277	SA 06-0000-0944	1.000 EA
RA386010	RA 06-0000-0944	1.000 EA
LB1115N	LABEL,LIFTING DEVICE (ON ROLLS)	1.000 EA
LB1119N	WARNING LABEL	1.000 EA
LC0006	CONNECTION LABEL	1.000 EA
LB1449	DIV-2/NEC WARNING LABEL	1.000 EA
PK3082	STYROFOAM CRADLE	1.000 EA
NP4224L	SS CP INV DIV-2 UL CSA-C US EEV PREM, DI	1.000 EA
85XU0407S04	4X1/4 U DRIVE PIN STAINLESS	2.000 EA
MN416A01	TAG-INSTAL-MAINT no wire (2100/bx) 4/22	1.000 EA
HW3201A05	3/8-16 EYEBOLT	1.000 EA
36FH4009A101	IEC FH NO GREASER, W/PRIMER	1.000 EA
51XW1032A06	10-32 X .38, TAPTITE II, HEX WSHR SLTD S	3.000 EA
34FN3002A02	EXTERNAL FAN, PLASTIC, .905/.907 HUB W/	1.000 EA
51XB0818A12	8-18X3/4 HXWSSLD SERTYB	1.000 EA
MJ1000A02	GREASE, MOBIL POLYREX EM - 124047	0.050 LB
HA3101A34	THRUBOLT- 1/4-20 X 10.375	4.000 EA
36EP3104B47	FREP MACH W/O GRSS,RAISED FH PADS,SLING	1.000 EA
HW4600B32SP	V-RING SLINGER 1.000 X 1.540 X .24 VITON	1.000 EA
HW5100A05	WVY WSHR F/205 & 304 BRGS	1.000 EA
HA4067A01	PUSH IN DRAIN FITTING (BLACK)	1.000 EA
36EP3301A34	SPL PU. ENDPLATE - ENCLOSED	1.000 EA
HW4600B36SP	V-RING SLINGER 1.188 X 1.690 X .24 VITON	1.000 EA
10XN2520A28	1/4-20X 1 3/4 HEX HD	4.000 EA

Parts List (continued)		
Part Number	Description	Quantity
HW1001A25	LOCKWASHER 1/4, ZINC PLT .493 OD, .255 I	4.000 EA
HA4067A01	PUSH IN DRAIN FITTING (BLACK)	1.000 EA
06CB3000	BALDOR CONDUIT BOX CAST	1.000 EA
06GS1000	GASKET,CONDUIT BOX	1.000 EA
51XW2520A12	SCREW, HEX SER SLT HD, ZN, 1/4-20 X .75	2.000 EA
11XW1032G06	10-32 X .38, TAPTITE II, HEX WSHR SLTD U	1.000 EA
HW3001B02	BRASS CUP WASHER W/GROUND SYMBOL TAB,	1.000 EA
06CB3500	BALDOR CONDUIT BOX LID	1.000 EA
06GS1001	BALDOR CONDUIT BOX GASKET	1.000 EA
51XW2520A12	.25-20 X .75, TAPTITE II, HEX WSHR SLTD	2.000 EA
MG1025L14	WILKOFASST, 776.14, GRUNDFOS BLACK	0.125 GA
36PA1001	PKG GRP, PRINT PK1017A06	1.000 EA
HW2501E16	KEY, 1/4 SQ X 1.750	1.000 EA
HA7000A02	KEY RETAINER RING, 1 1/8 DIA, 1 3/8 DIA	1.000 EA

AC Induction Motor Performance Data

Record # 88469

Typical performance - not guaranteed values

Winding: 06WGY425-R001		Type: 0642M	Enclosure: TEFC		
Nameplate Data			575 V, 60 Hz: Single Voltage Motor		
Rated Output (HP)	5	Full Load Torque	15 LB-FT		
Volts	575	Start Configuration	direct on line		
Full Load Amps	5.3	Breakdown Torque	43.1 LB-FT		
R.P.M.	1750	Pull-up Torque	28.37 LB-FT		
Hz	60 Phase	3	Locked-rotor Torque	25.4 LB-FT	
NEMA Design Code	B	KVA Code	H	Starting Current	26.7 A
Service Factor (S.F.)	1.15	No-load Current	2.33 A		
NEMA Nom. Eff.	89.5	Power Factor	81	Line-line Res. @ 25°C	3.96 Ω
Rating - Duty	50C AMB-CONT		Temp. Rise @ Rated Load	49°C	
S.F. Amps			Temp. Rise @ S.F. Load	59°C	
			Locked-rotor Power Factor	39.7	
			Rotor inertia	0.391 lb-ft ²	

Load Characteristics 575 V, 60 Hz, 5 HP

% of Rated Load	25	50	75	100	125	150	S.F.
Power Factor	43	66	77	83	86	87	85
Efficiency	84.2	89	89.9	89.5	88.6	87.3	89
Speed	1789	1778	1766	1753	1739	1724	1745
Line amperes	2.59	3.21	4.06	5.05	6.17	7.42	5.72

Performance Graph at 575V, 60Hz, 5.0HP Typical performance - Not guaranteed values

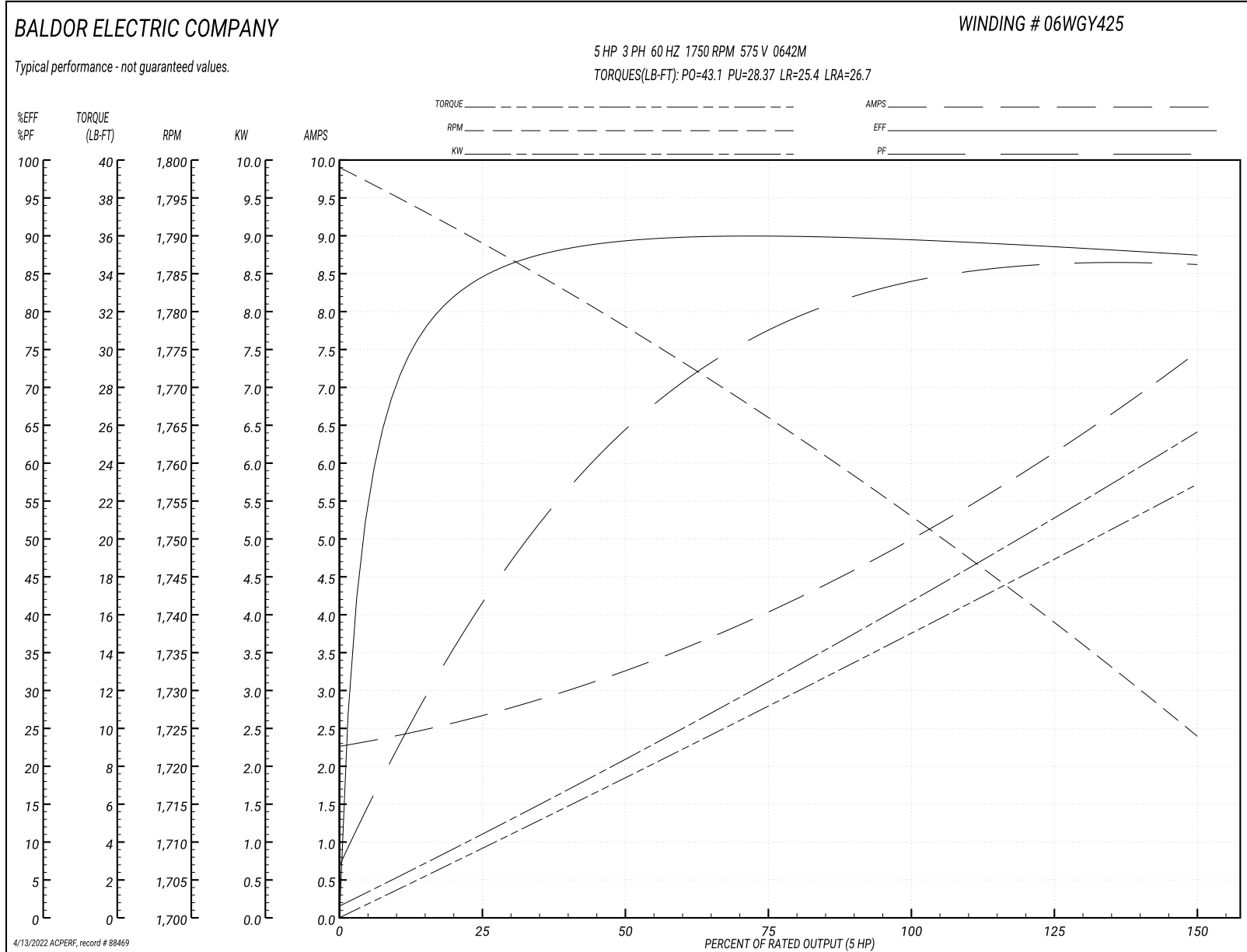

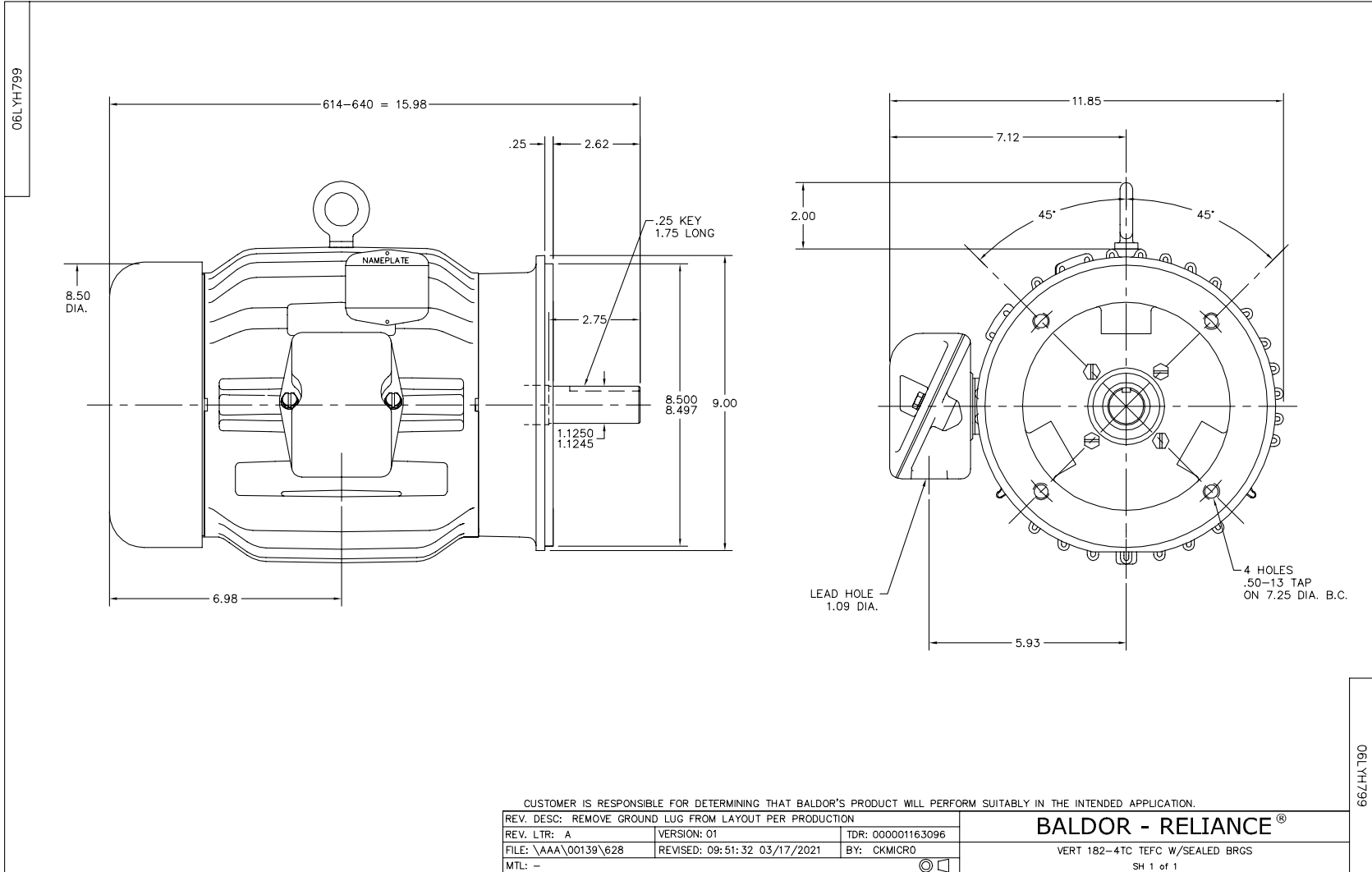

CD0006



NOTES:

1. THREE LEAD MOTOR MAY BE EITHER WYE CONNECTED OR DELTA CONNECTED.
2. INTERCHANGE ANY TWO LINE LEADS TO REVERSE ROTATION.
3. OPTIONAL THERMOSTATS ARE PROVIDED WHEN SPECIFIED.
4. ACTUAL NUMBER OF INTERNAL PARALLEL CIRCUITS MAY VARY.
5. LEAD COLORS ARE OPTIONAL. LEADS MUST BE NUMBERED AS SHOWN.

CD0006

REV. DESC: ADD CLASS CONN00000007		
REV. LTR: E	VERSION: 01	TDR: 000001099922
FILE: \AAA\00005\141	REVISED: 10:24:49 02/19/2019	BY: ENBRIRO
MTL: -	© □	

BALDOR - RELIANCE®

3PH, SV, 3 LEADS, WYE OR DELTA CONNECTED

SH 1 of 1

Marketing maintained PDF of MN416:

<http://www.baldor.com/support/Literature/Load.ashx/MN416?ManNumber=MN416>