

DATA SHEET

Three Phase Induction Motor - Squirrel Cage



Customer :		
Product line	: NEMA Premium Efficiency Three-Phase	
Product code :	12628412	
Catalog # :	00156OT3E143T-S	
Frame	: 143/5T	
Insulation class	: F	
Duty cycle	: Cont.(S1)	
Ambient temperature	: -20°C to +40°C	
Altitude	: 1000 m.a.s.l.	
Design	: B	
Cooling method	: IC01 - ODP	
Mounting	: F-1	
Rotation ¹	: Both (CW and CCW)	
Starting method	: Direct On Line	
Approx. weight ²	: 29.8 lb	
Moment of inertia (J)	: 0.0835 sq.ft.lb	
Output [HP]	1.5	
Poles	2	
Frequency [Hz]	60	
Rated voltage [V]	230/460	
Rated current [A]	3.70/1.85	
L. R. Amperes [A]	31.8/15.9	
LRC [A]	8.6x(Code K)	
No load current [A]	1.62/0.809	
Rated speed [RPM]	3510	
Slip [%]	2.50	
Rated torque [ft.lb]	2.24	
Locked rotor torque [%]	210	
Breakdown torque [%]	330	
Service factor	1.15	
Temperature rise	80 K	
Locked rotor time	34s (cold) 19s (hot)	
Noise level ²	62.0 dB(A)	
Efficiency (%)	25%	81.1
	50%	81.5
	75%	84.0
	100%	84.0
Power Factor	25%	0.45
	50%	0.73
	75%	0.83
	100%	0.89
Bearing type	: <u>Drive end</u> 6205 ZZ <u>Non drive end</u> 6203 ZZ	
Sealing	: Without Without	
	: Bearing Seal Bearing Seal	
Lubrication interval	: - -	
Lubricant amount	: - -	
Lubricant type	: Mobil Polyrex EM	
Foundation loads	Max. traction : 51 lb	
	Max. compression : 81 lb	
Notes		
USABLE @208V 4.09A SF 1.00 SFA 4.09A		
This revision replaces and cancel the previous one, which must be eliminated.		
(1) Looking the motor from the shaft end.		
(2) Measured at 1m and with tolerance of +3dB(A).		
(3) Approximate weight subject to changes after manufacturing process.		
(4) At 100% of full load.		
These are average values based on tests with sinusoidal power supply, subject to the tolerances stipulated in NEMA MG-1.		
Rev.	Changes Summary	
Performed by	Performed	
Checked by	Checked	
Date	Date	
12/04/2022		
Page	Revision	
1 /		

TORQUE AND CURRENT VS SPEED CURVE

Three Phase Induction Motor - Squirrel Cage



Customer :

Product line : NEMA Premium Efficiency Three-Phase

Product code : 12628412

Catalog # : 00156OT3E143T-S

TORQUE AND CURRENT VS SPEED CURVE

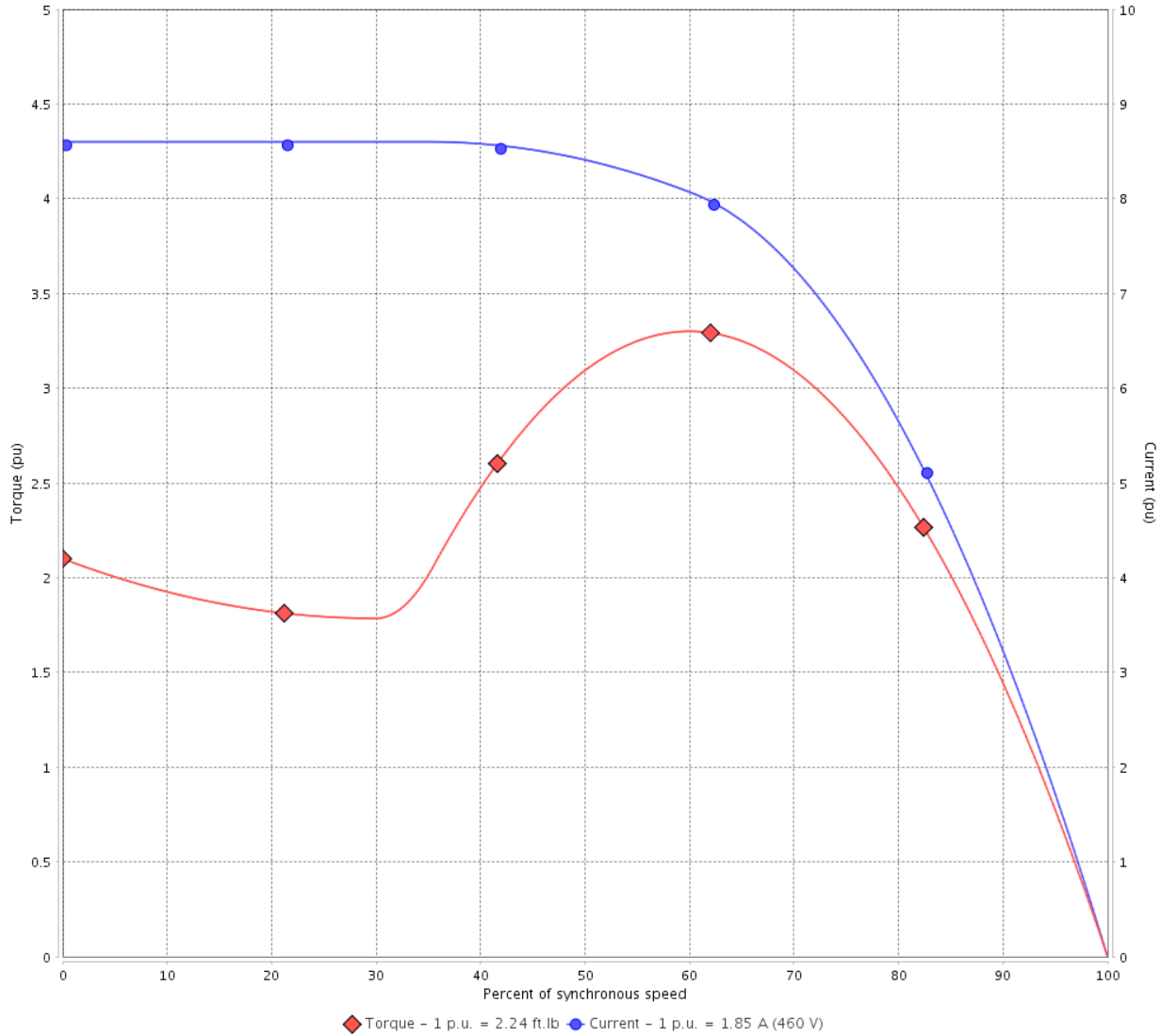

Performance : 230/460 V 60 Hz 2P

Rated current	: 3.70/1.85 A	Moment of inertia (J)	: 0.0835 sq.ft.lb
LRC	: 8.6	Duty cycle	: Cont.(S1)
Rated torque	: 2.24 ft.lb	Insulation class	: F
Locked rotor torque	: 210 %	Service factor	:
Breakdown torque	: 330 %	Temperature rise	: 80 K
Rated speed	: 3510 rpm	Design	: B

Locked rotor time : 34s (cold) 19s (hot)

Rev.	Changes Summary	Performed	Checked	Date
Performed by			Page 2 /	Revision
Checked by				
Date	12/04/2022			

TORQUE AND CURRENT VS SPEED CURVE



Three Phase Induction Motor - Squirrel Cage

Customer :

Product line : NEMA Premium Efficiency Three-Phase

Product code : 12628412

Catalog # : 00156OT3E143T-S

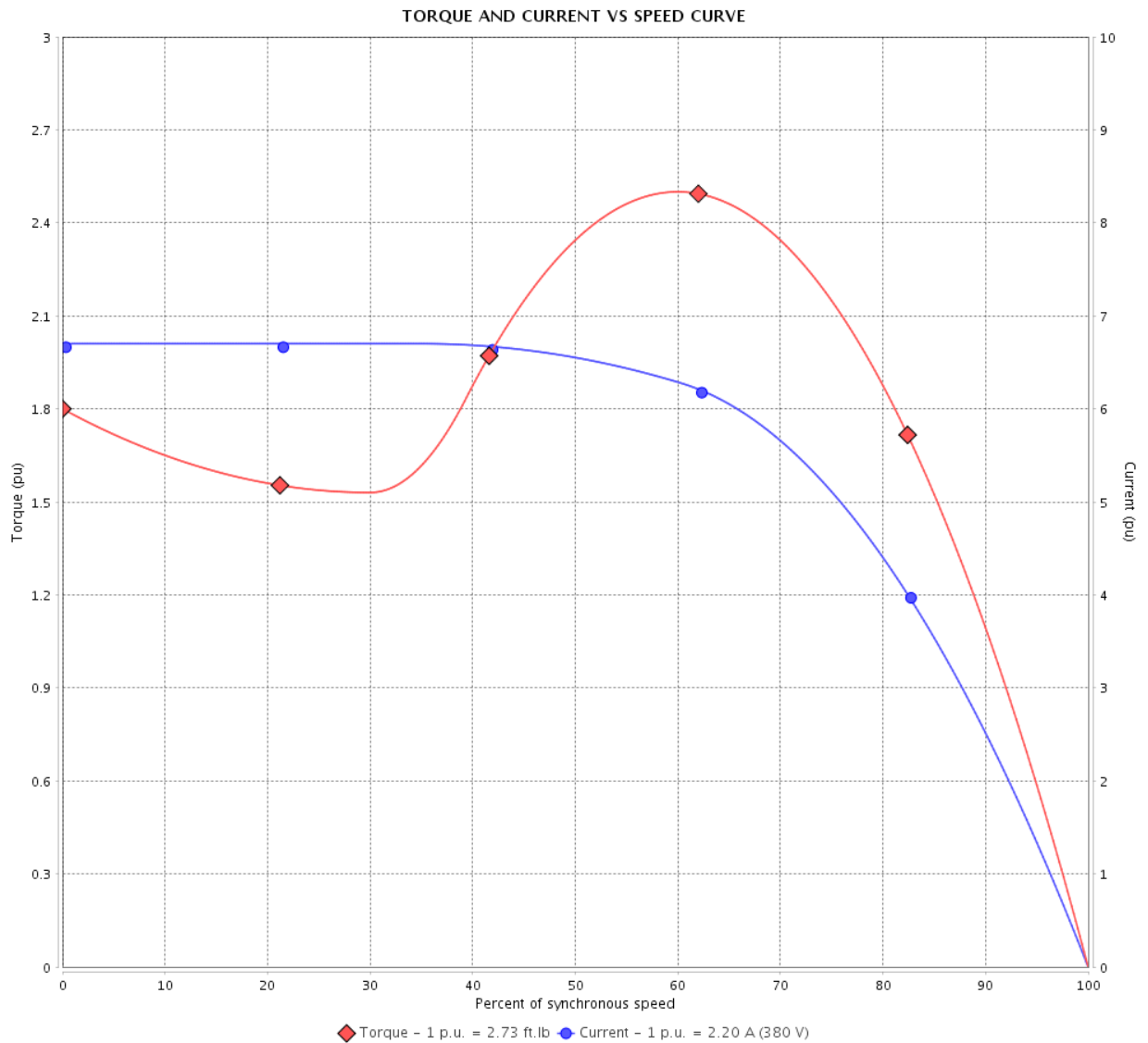

Performance : 190/380 V 50 Hz 2P

Rated current : 4.40/2.20 A
 LRC : 6.7
 Rated torque : 2.73 ft.lb
 Locked rotor torque : 180 %
 Breakdown torque : 250 %
 Rated speed : 2890 rpm

Moment of inertia (J) : 0.0835 sq.ft.lb
 Duty cycle : Cont.(S1)
 Insulation class : F
 Service factor : 1.15
 Temperature rise : 80 K
 Design : B

Locked rotor time : 0s (cold) 0s (hot)

Rev.	Changes Summary	Performed	Checked	Date
Performed by			Page 3 /	Revision
Checked by				
Date	12/04/2022			

TORQUE AND CURRENT VS SPEED CURVE

Three Phase Induction Motor - Squirrel Cage



Customer :

Product line : NEMA Premium Efficiency Three-Phase

Product code : 12628412

Catalog # : 00156OT3E143T-S

TORQUE AND CURRENT VS SPEED CURVE

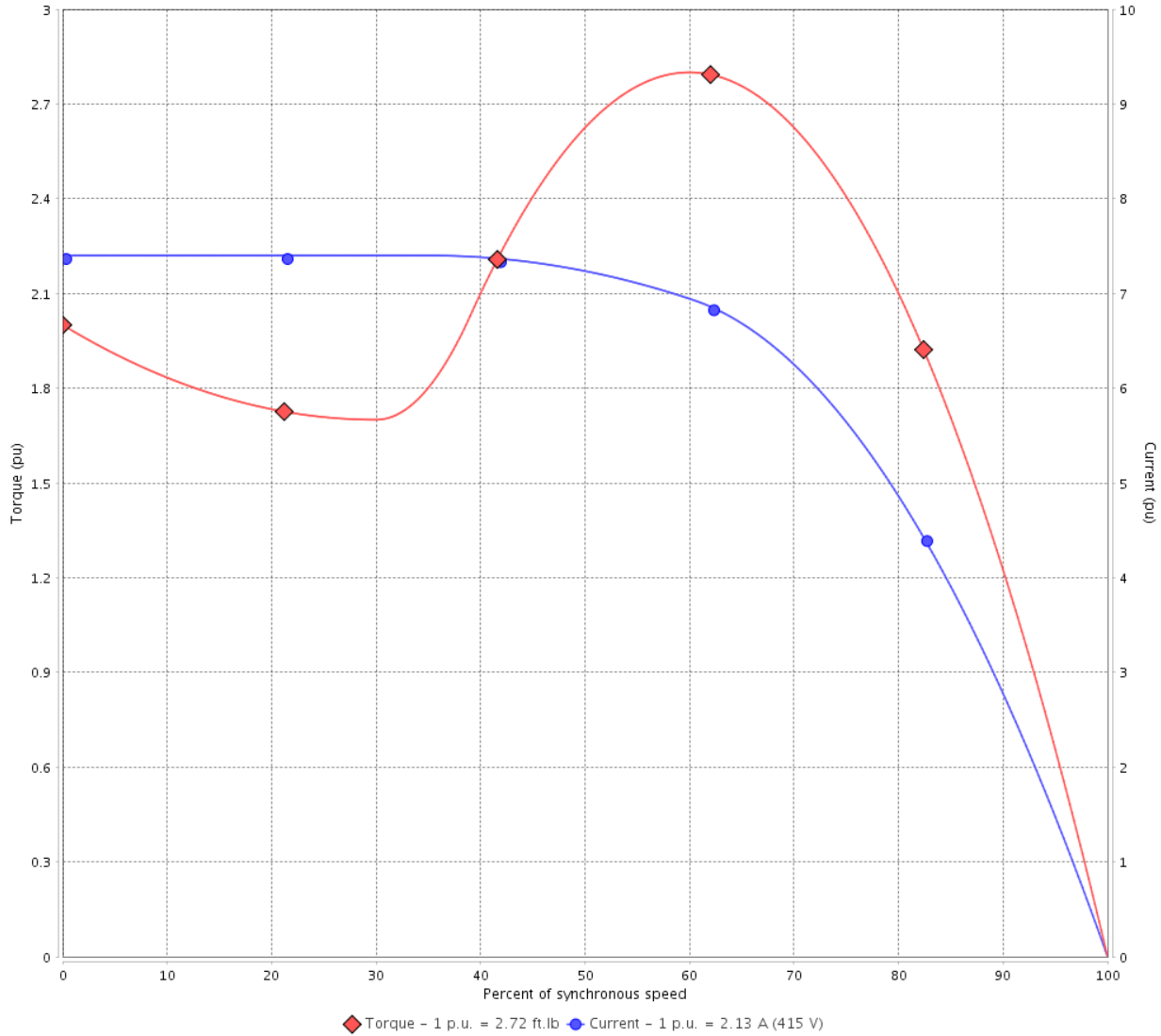

Performance : 220/415 V 50 Hz 2P

Rated current : 4.02/2.13 A
 LRC : 7.4
 Rated torque : 2.72 ft.lb
 Locked rotor torque : 200 %
 Breakdown torque : 280 %
 Rated speed : 2900 rpm

Moment of inertia (J) : 0.0835 sq.ft.lb
 Duty cycle : Cont.(S1)
 Insulation class : F
 Service factor : 1.15
 Temperature rise : 80 K
 Design : B

Locked rotor time : 0s (cold) 0s (hot)

Rev.	Changes Summary	Performed	Checked	Date
Performed by			Page 4 /	Revision
Checked by				
Date	12/04/2022			

LOAD PERFORMANCE CURVE

Three Phase Induction Motor - Squirrel Cage



Customer :

Product line : NEMA Premium Efficiency Three-Phase

Product code : 12628412

Catalog # : 00156OT3E143T-S

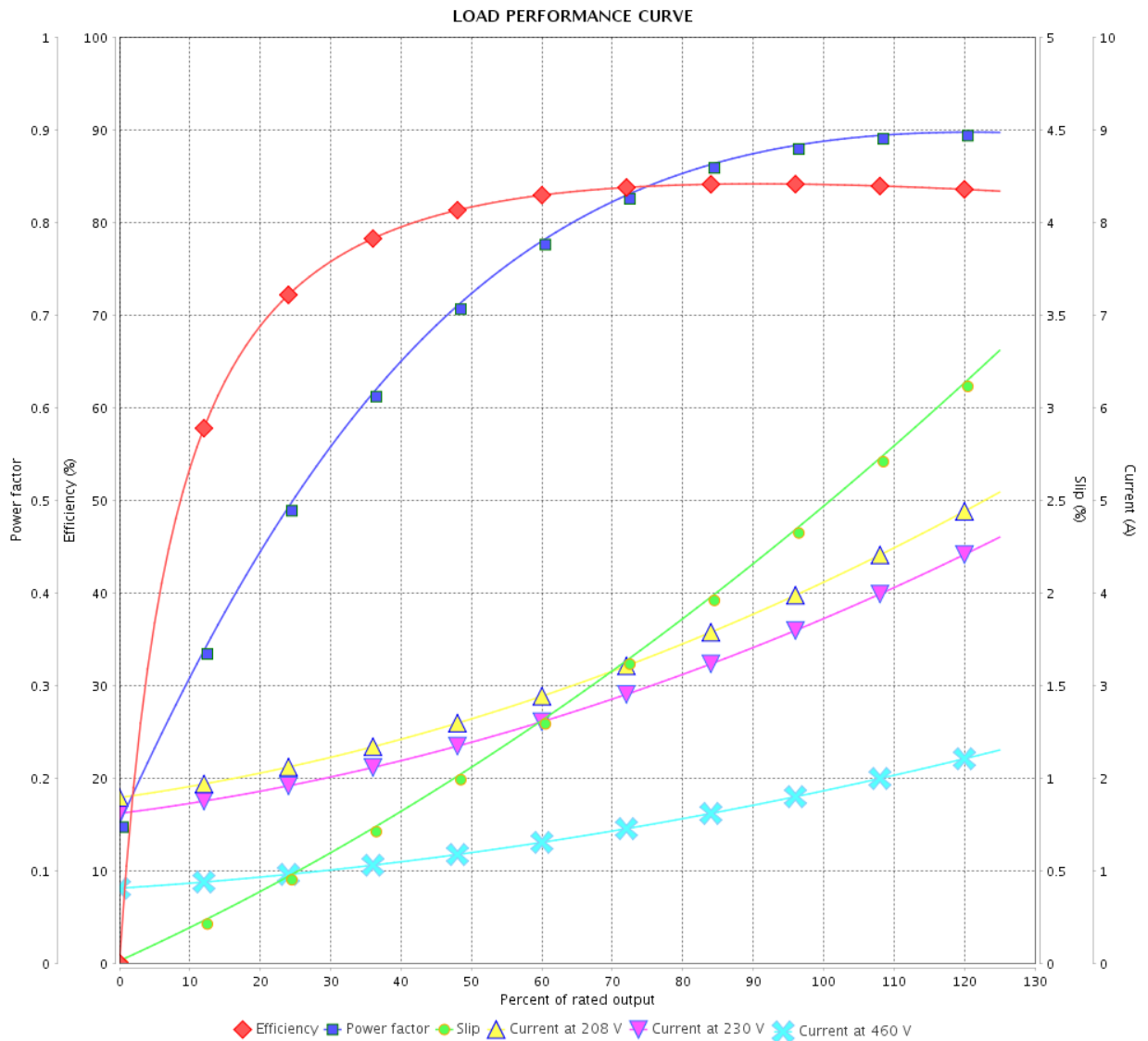

Performance : 230/460 V 60 Hz 2P

Rated current : 3.70/1.85 A
 LRC : 8.6
 Rated torque : 2.24 ft.lb
 Locked rotor torque : 210 %
 Breakdown torque : 330 %
 Rated speed : 3510 rpm

Moment of inertia (J) : 0.0835 sq.ft.lb
 Duty cycle : Cont.(S1)
 Insulation class : F
 Service factor :
 Temperature rise : 80 K
 Design : B

Rev.	Changes Summary	Performed	Checked	Date
Performed by			Page	Revision
Checked by			5 /	
Date	12/04/2022			

LOAD PERFORMANCE CURVE

Three Phase Induction Motor - Squirrel Cage



Customer :

Product line : NEMA Premium Efficiency Three-Phase

Product code : 12628412

Catalog # : 00156OT3E143T-S

LOAD PERFORMANCE CURVE

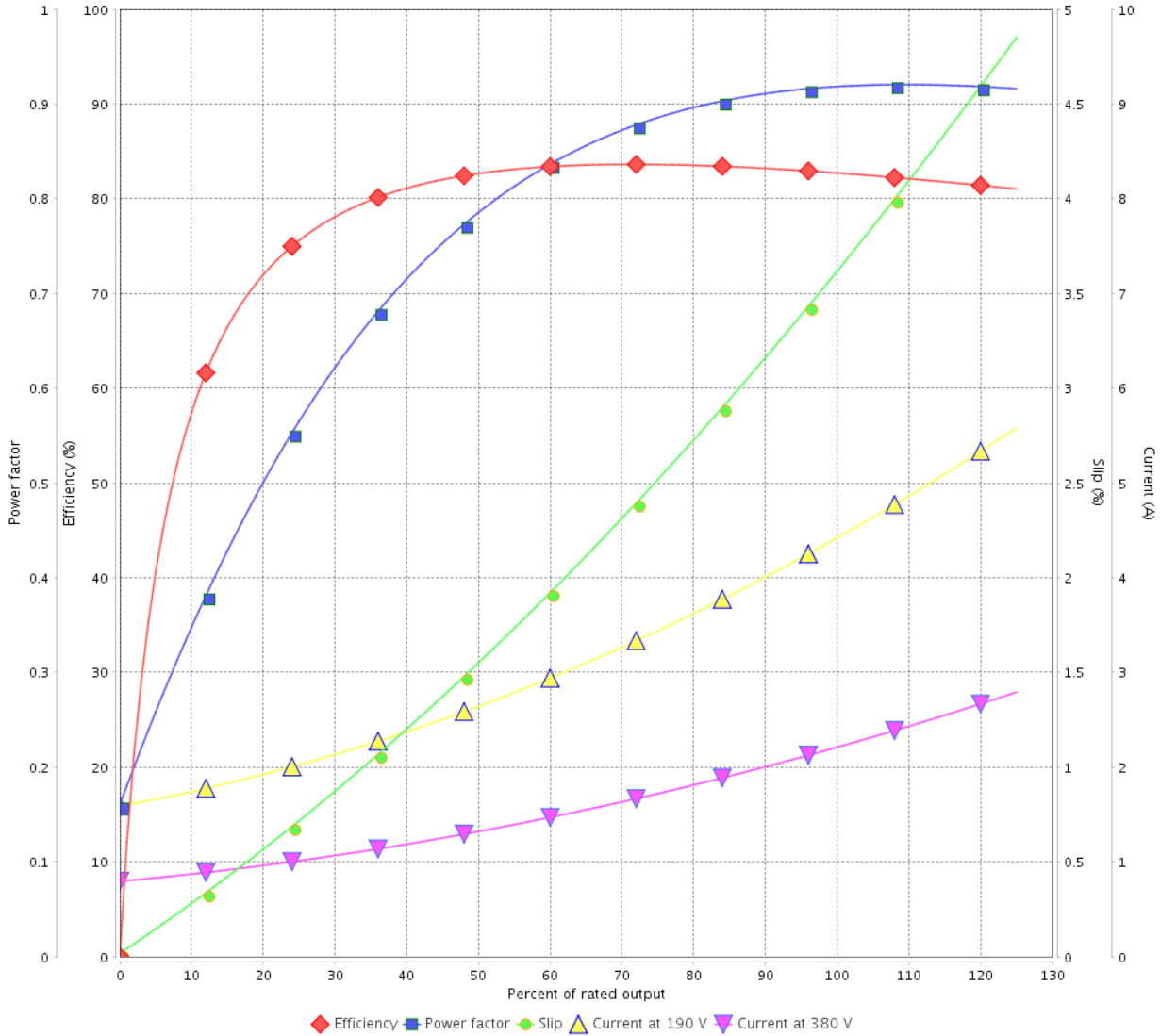

Performance : 190/380 V 50 Hz 2P

Rated current : 4.40/2.20 A
 LRC : 6.7
 Rated torque : 2.73 ft.lb
 Locked rotor torque : 180 %
 Breakdown torque : 250 %
 Rated speed : 2890 rpm

Moment of inertia (J) : 0.0835 sq.ft.lb
 Duty cycle : Cont.(S1)
 Insulation class : F
 Service factor : 1.15
 Temperature rise : 80 K
 Design : B

Rev.	Changes Summary	Performed	Checked	Date
Performed by		Page		Revision
Checked by		6 /		
Date	12/04/2022			

LOAD PERFORMANCE CURVE

Three Phase Induction Motor - Squirrel Cage



Customer :

Product line : NEMA Premium Efficiency Three-Phase

Product code : 12628412

Catalog # : 00156OT3E143T-S

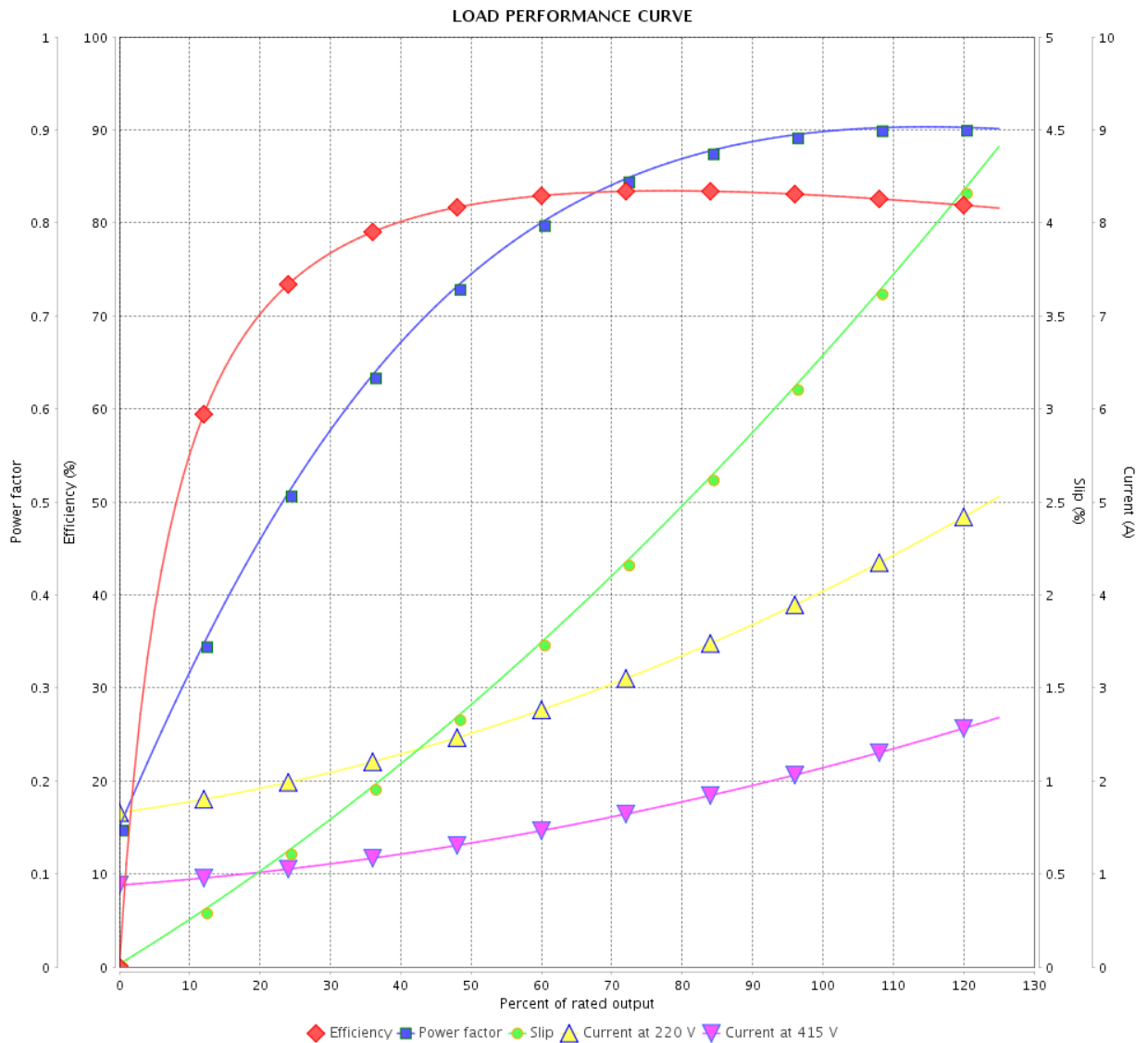

Performance : 220/415 V 50 Hz 2P

Rated current : 4.02/2.13 A
 LRC : 7.4
 Rated torque : 2.72 ft.lb
 Locked rotor torque : 200 %
 Breakdown torque : 280 %
 Rated speed : 2900 rpm

Moment of inertia (J) : 0.0835 sq.ft.lb
 Duty cycle : Cont.(S1)
 Insulation class : F
 Service factor : 1.15
 Temperature rise : 80 K
 Design : B

Rev.	Changes Summary	Performed	Checked	Date
Performed by		Page		Revision
Checked by		7 /		
Date		12/04/2022		

THERMAL LIMIT CURVE



Three Phase Induction Motor - Squirrel Cage

Customer :

Product line : NEMA Premium Efficiency Three-Phase
Product code : 12628412
Catalog # : 00156OT3E143T-S

Performance : 230/460 V 60 Hz 2P

Rated current	: 3.70/1.85 A	Moment of inertia (J)	: 0.0835 sq.ft.lb
LRC	: 8.6	Duty cycle	: Cont.(S1)
Rated torque	: 2.24 ft.lb	Insulation class	: F
Locked rotor torque	: 210 %	Service factor	:
Breakdown torque	: 330 %	Temperature rise	: 80 K
Rated speed	: 3510 rpm	Design	: B

Heating constant

Cooling constant

Rev.	Changes Summary	Performed	Checked	Date
Performed by				
Checked by			Page	Revision
Date	12/04/2022		8 /	

THERMAL LIMIT CURVE

Three Phase Induction Motor - Squirrel Cage



Customer : _____

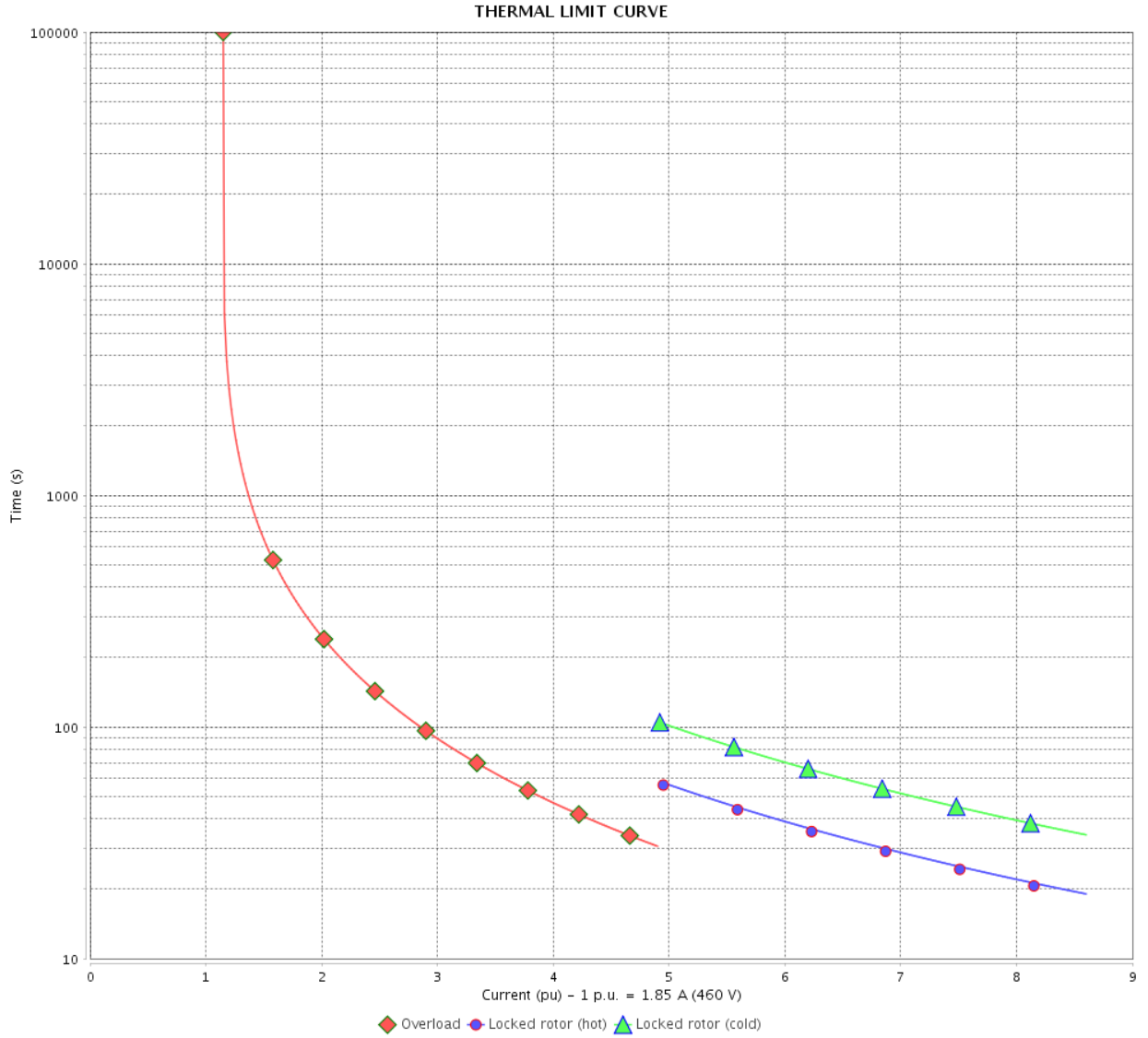

Rev.	Changes Summary	Performed	Checked	Date
Performed by		Page		Revision
Checked by		9 /		
Date		12/04/2022		

THERMAL LIMIT CURVE



Three Phase Induction Motor - Squirrel Cage

Customer :

Product line : NEMA Premium Efficiency Three-Phase
Product code : 12628412
Catalog # : 00156OT3E143T-S

Performance : 190/380 V 50 Hz 2P

Rated current	: 4.40/2.20 A	Moment of inertia (J)	: 0.0835 sq.ft.lb
LRC	: 6.7	Duty cycle	: Cont.(S1)
Rated torque	: 2.73 ft.lb	Insulation class	: F
Locked rotor torque	: 180 %	Service factor	: 1.15
Breakdown torque	: 250 %	Temperature rise	: 80 K
Rated speed	: 2890 rpm	Design	: B

Heating constant

Cooling constant

Rev.	Changes Summary	Performed	Checked	Date
Performed by				
Checked by			Page	Revision
Date	12/04/2022		10 /	

THERMAL LIMIT CURVE

Three Phase Induction Motor - Squirrel Cage



Customer : _____

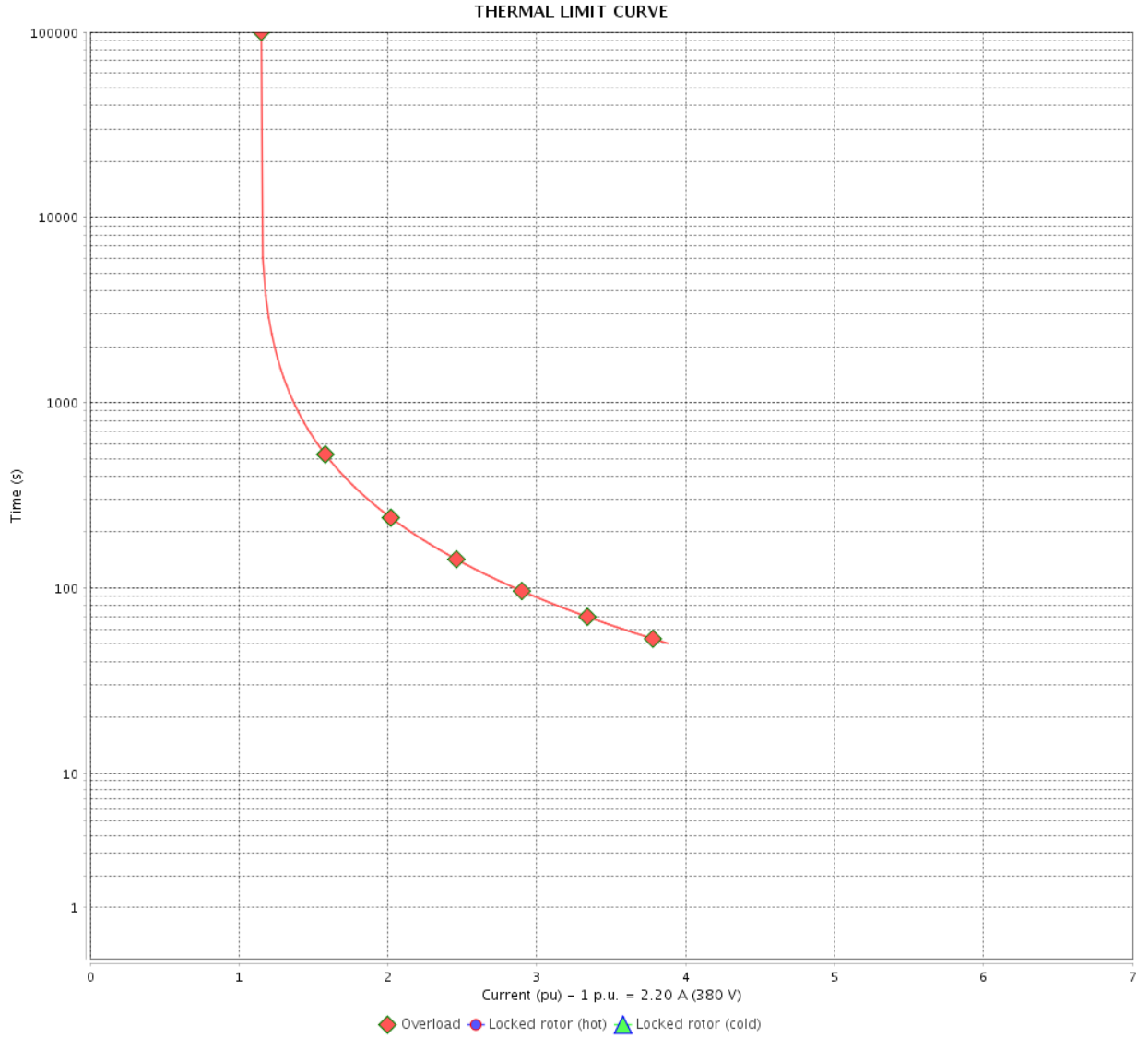

Rev.	Changes Summary	Performed	Checked	Date
Performed by		Page		Revision
Checked by		11 /		
Date		12/04/2022		

THERMAL LIMIT CURVE



Three Phase Induction Motor - Squirrel Cage

Customer :

Product line : NEMA Premium Efficiency Three-Phase
 Product code : 12628412
 Catalog # : 00156OT3E143T-S

Performance : 220/415 V 50 Hz 2P

Rated current : 4.02/2.13 A	Moment of inertia (J) : 0.0835 sq.ft.lb
LRC : 7.4	Duty cycle : Cont.(S1)
Rated torque : 2.72 ft.lb	Insulation class : F
Locked rotor torque : 200 %	Service factor : 1.15
Breakdown torque : 280 %	Temperature rise : 80 K
Rated speed : 2900 rpm	Design : B

Heating constant

Cooling constant

Rev.	Changes Summary	Performed	Checked	Date
Performed by			Page 12 /	Revision
Checked by				
Date	12/04/2022			

THERMAL LIMIT CURVE

Three Phase Induction Motor - Squirrel Cage



Customer : _____

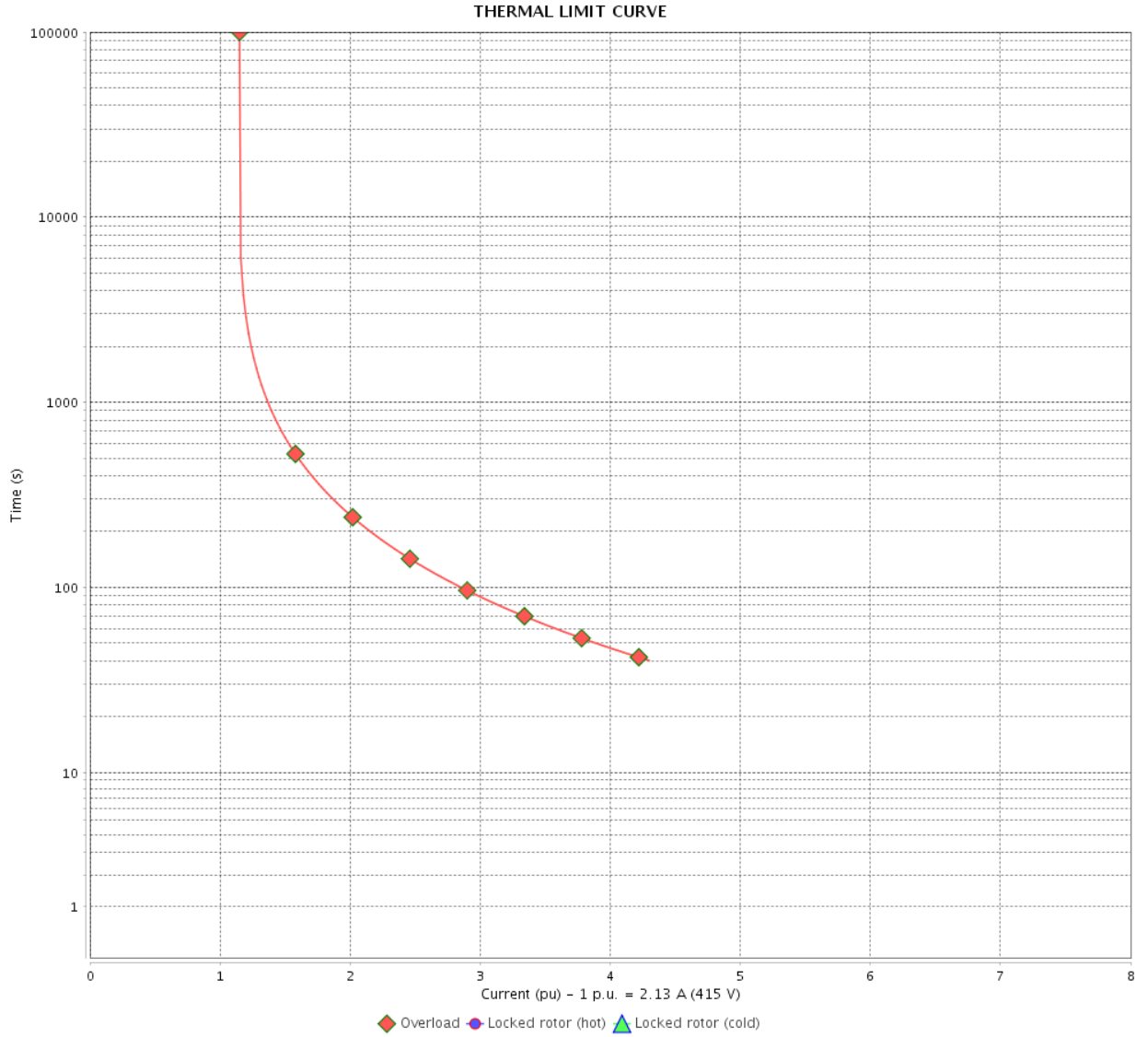

Rev.	Changes Summary	Performed	Checked	Date
Performed by		Page		Revision
Checked by		13 /		
Date		12/04/2022		

VFD OPERATION CURVE

Three Phase Induction Motor - Squirrel Cage



Customer :

Product line : NEMA Premium Efficiency Three-Phase

Product code : 12628412

Catalog # : 00156OT3E143T-S

VFD OPERATION CURVE

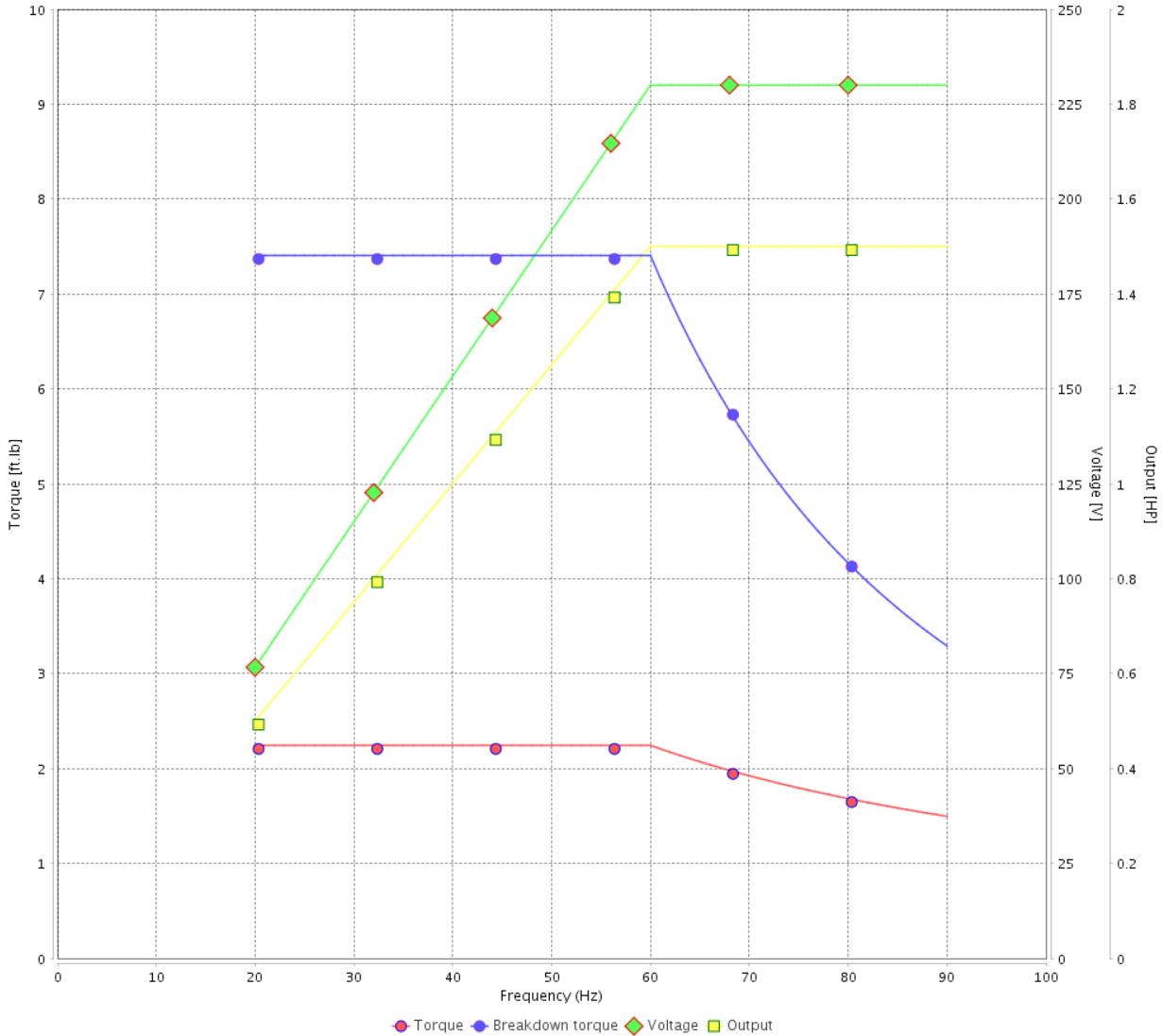

Performance : 230/460 V 60 Hz 2P

Rated current : 3.70/1.85 A
 LRC : 8.6
 Rated torque : 2.24 ft.lb
 Locked rotor torque : 210 %
 Breakdown torque : 330 %
 Rated speed : 3510 rpm

Moment of inertia (J) : 0.0835 sq.ft.lb
 Duty cycle : Cont.(S1)
 Insulation class : F
 Service factor :
 Temperature rise : 80 K
 Design : B

Rev.	Changes Summary	Performed	Checked	Date
Performed by			Page 14 /	Revision
Checked by				
Date	12/04/2022			

1 2 3 4 5 6

A

B

C

D

E

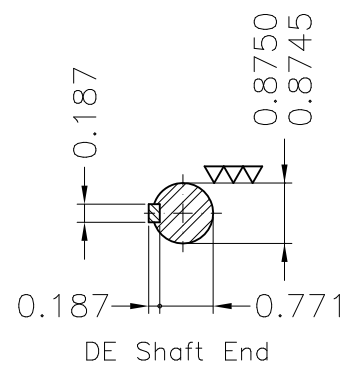
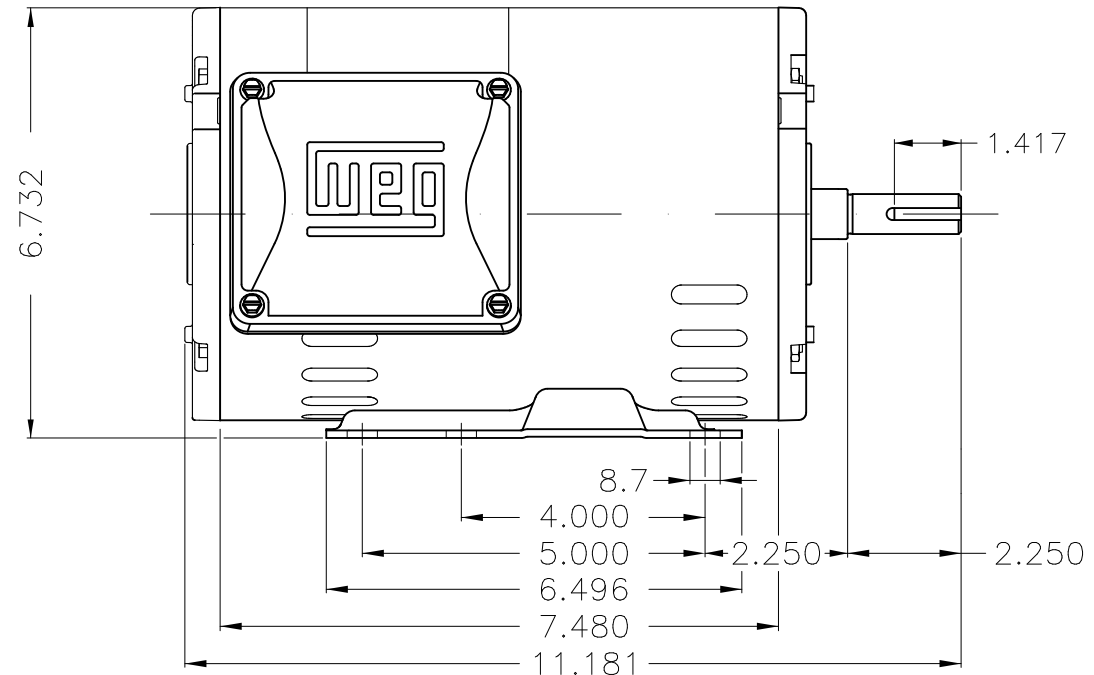
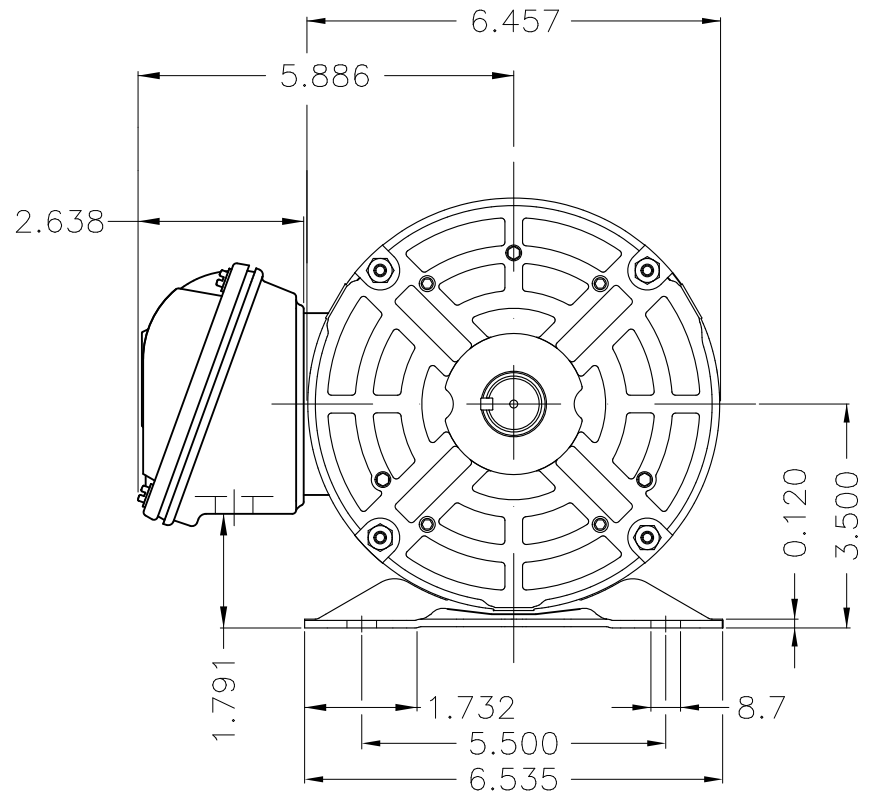

Dimensions in inches

Color Munsell N 1 matte black
 Painting plan 207N
 Mounting F-1/B3R(D)

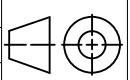
ECM	LOC	SUMMARY OF MODIFICATIONS	EXECUTED	CHECKED	RELEASED	DATE	VER
EXECUTED	PIRWBUSER	 THREE PH. MOTOR ROLLED STEEL PREM. EFF. FRAME 143/5T IP21 ODP					
CHECKED							
RELEASED							
REL DT.	WMO	Jaragua do Sul	Product Engineering	SHEET		1 / 1	

PREVIEW
WDD



1.5 HP 02 Poles 60 Hz



NEMA
Premium



MADE IN BRAZIL

MAT: 12628412 CC029A
W01.T00IC0X0N
MODEL 001560T3E143T-S
14MAR2022 B/N:



PH 3	Hz 60	HP 1.5
FR 143/5T		KW 1.1
DUTY CONT.		V 230/460
ALT 1000 m.a.s.l.		A 3.70/1.85
INS CL F AT 80K		SFA 4.25/2.13
AMB 40°C	DES B	SF 1.15
ENCL ODP	CODE K	PF 0.89
USABLE @ 208V 4.09A		RPM 3510
SF1.00		NEMA NOM. EFF 84.0%
ALTERNATE RATING: 1.5HP 50Hz 190-220/380-415V SF1.15		
4.40-3.94/2.20-2.09A 2890RPM EFF 82.7% (IE3) IEC 60034-1		
Inverter duty motor For 80Hz use on VPWM 1000:1 VT, 3:1 CT		
DE 6205-ZZ	ODE 6203-ZZ	MOBIL POLYREX EM



T1-BLU T2-WHT
T3-ORG T4-YEL
T5-BLK T6-GRY
T7-PNK T8-RED
T9-BRK RED

INTERCHANGE ANY TWO LINE WIRES TO REVERSE THE ROTATION



WARNING: Motor must be grounded in accordance with local and national electrical codes to prevent serious electrical shocks. Disconnect power source before servicing unit.

AVERTISSEMENT: Le moteur doit être mis à la terre

conformément aux codes électriques locaux et nationaux afin d'éviter tout choc électrique grave. Déconnectez l'alimentation avant l'entretien de la machine.

