

# DATA SHEET



## Three Phase Induction Motor - Squirrel Cage

Customer :				
Product line	: JM Pump NEMA Premium Efficiency Three-Phase			
Product code :	14808488			
Catalog # :	00158ET3V145JM-S			
Frame : 143/5JM Output : 1.5 HP (1.1 kW) Poles : 4 Frequency : 60 Hz Rated voltage : 200/400 V Rated current : 4.65/2.32 A L. R. Amperes : 38.1/19.0 A LRC : 8.2x(Code K) No load current : 2.49/1.25 A Rated speed : 1750 rpm Slip : 2.78 % Rated torque : 4.50 ft.lb Locked rotor torque : 270 % Breakdown torque : 300 % Insulation class : F Service factor : 1.15 Moment of inertia (J) : 0.1101 sq.ft.lb Design : B	Locked rotor time : 37s (cold) 21s (hot) Temperature rise : 80 K Duty cycle : Cont.(S1) Ambient temperature : -20°C to +40°C Altitude : 1000 m.a.s.l. Protection degree : IP55 Cooling method : IC411 - TEFC Mounting : F-1 Rotation <sup>1</sup> : Both (CW and CCW) Noise level <sup>2</sup> : 52.0 dB(A) Starting method : Direct On Line Approx. weight <sup>3</sup> : 40.9 lb			
Output	25%    50%    75%    100%			
Efficiency (%)	85.2    85.5    86.5    86.5			
Power Factor	0.35    0.59    0.72    0.79			
Foundation loads				
Max. traction : 97 lb				
Max. compression : 138 lb				
Bearing type	: <u>Drive end</u> 6206 ZZ <u>Non drive end</u> 6203 ZZ			
Sealing	: V'Ring    Without Bearing Seal			
Lubrication interval	: -    -			
Lubricant amount	: -    -			
Lubricant type	: Mobil Polyrex EM			
Notes				
This revision replaces and cancel the previous one, which must be eliminated. (1) Looking the motor from the shaft end. (2) Measured at 1m and with tolerance of +3dB(A). (3) Approximate weight subject to changes after manufacturing process. (4) At 100% of full load.				
These are average values based on tests with sinusoidal power supply, subject to the tolerances stipulated in NEMA MG-1.				
Rev.	Changes Summary	Performed	Checked	Date
Performed by				
Checked by			Page	Revision
Date	12/04/2022		1 / 6	

# TORQUE AND CURRENT VS SPEED CURVE

## Three Phase Induction Motor - Squirrel Cage



Customer :

Product line : JM Pump NEMA Premium  
Efficiency Three-Phase

Product code : 14808488

Catalog # : 00158ET3V145JM-S

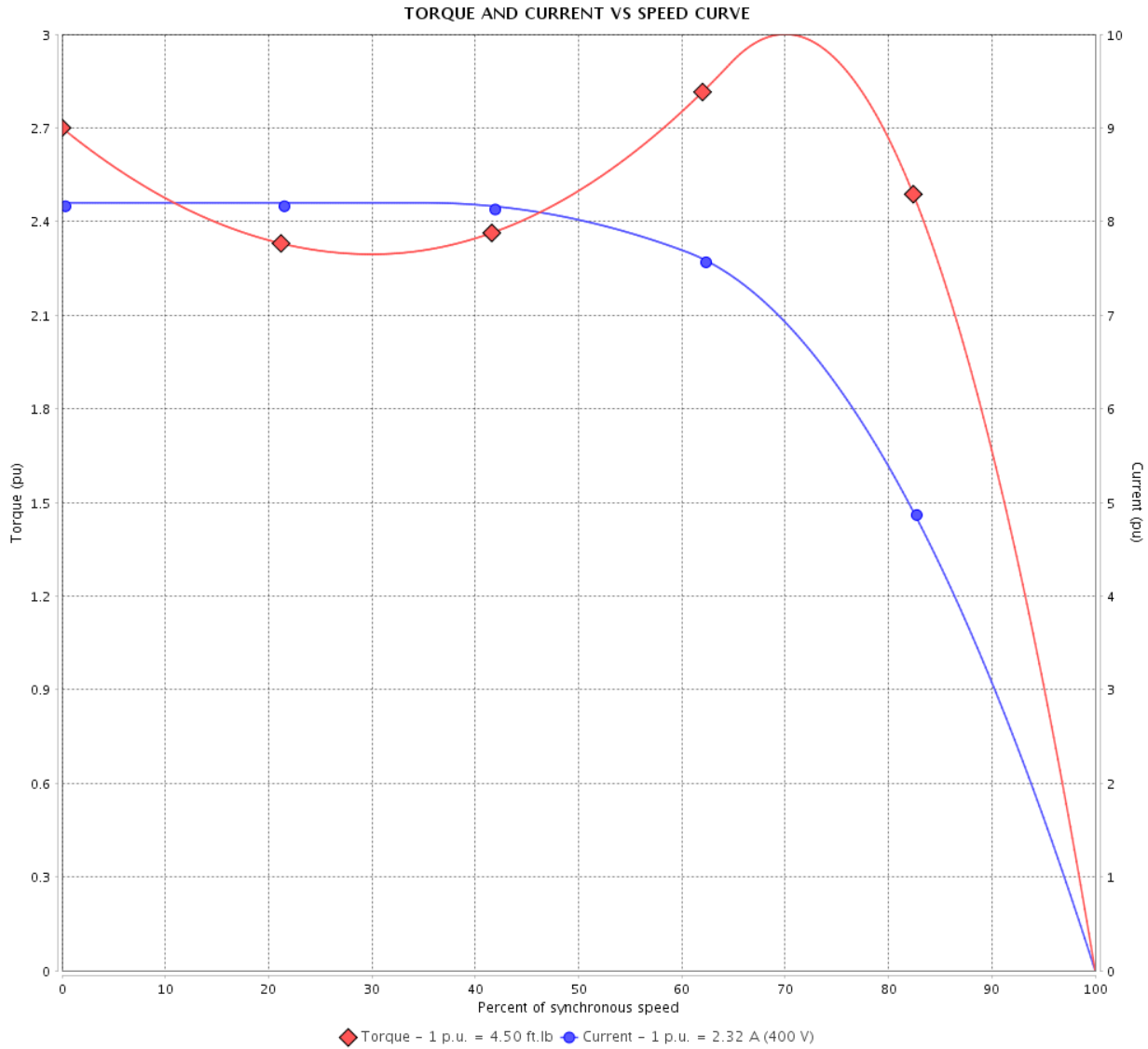

Performance : 200/400 V 60 Hz 4P

Rated current : 4.65/2.32 A  
LRC : 8.2  
Rated torque : 4.50 ft.lb  
Locked rotor torque : 270 %  
Breakdown torque : 300 %  
Rated speed : 1750 rpm

Moment of inertia (J) : 0.1101 sq.ft.lb  
Duty cycle : Cont.(S1)  
Insulation class : F  
Service factor : 1.15  
Temperature rise : 80 K  
Design : B

Locked rotor time : 37s (cold) 21s (hot)

Rev.	Changes Summary	Performed	Checked	Date
Performed by			Page 2 / 6	Revision
Checked by				
Date	12/04/2022			

# LOAD PERFORMANCE CURVE

## Three Phase Induction Motor - Squirrel Cage



Customer :

Product line : JM Pump NEMA Premium  
Efficiency Three-Phase

Product code : 14808488

Catalog # : 00158ET3V145JM-S

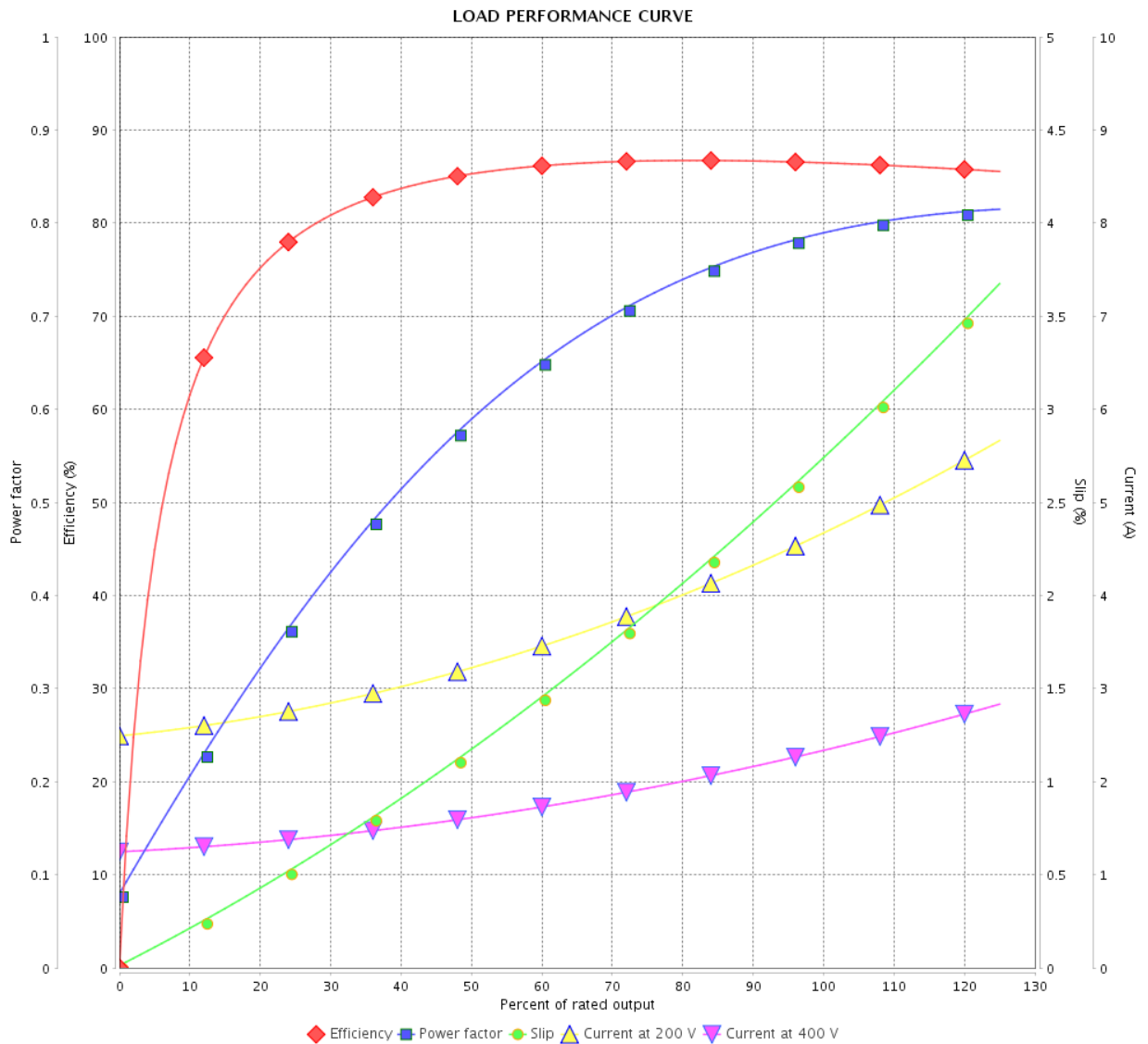

Performance : 200/400 V 60 Hz 4P

Rated current : 4.65/2.32 A  
 LRC : 8.2  
 Rated torque : 4.50 ft.lb  
 Locked rotor torque : 270 %  
 Breakdown torque : 300 %  
 Rated speed : 1750 rpm

Moment of inertia (J) : 0.1101 sq.ft.lb  
 Duty cycle : Cont.(S1)  
 Insulation class : F  
 Service factor : 1.15  
 Temperature rise : 80 K  
 Design : B

Rev.	Changes Summary	Performed	Checked	Date
Performed by		Page		Revision
Checked by		3 / 6		
Date		12/04/2022		

# THERMAL LIMIT CURVE



## Three Phase Induction Motor - Squirrel Cage

Customer :

Product line : JM Pump NEMA Premium  
Efficiency Three-Phase

Product code : 14808488

Catalog # : 00158ET3V145JM-S

Performance : 200/400 V 60 Hz 4P

Rated current : 4.65/2.32 A  
LRC : 8.2  
Rated torque : 4.50 ft.lb  
Locked rotor torque : 270 %  
Breakdown torque : 300 %  
Rated speed : 1750 rpm

Moment of inertia (J) : 0.1101 sq.ft.lb  
Duty cycle : Cont.(S1)  
Insulation class : F  
Service factor : 1.15  
Temperature rise : 80 K  
Design : B

Heating constant

Cooling constant

Rev.	Changes Summary	Performed	Checked	Date
Performed by				
Checked by			Page	Revision
Date	12/04/2022		4 / 6	

# THERMAL LIMIT CURVE

## Three Phase Induction Motor - Squirrel Cage



Customer : \_\_\_\_\_

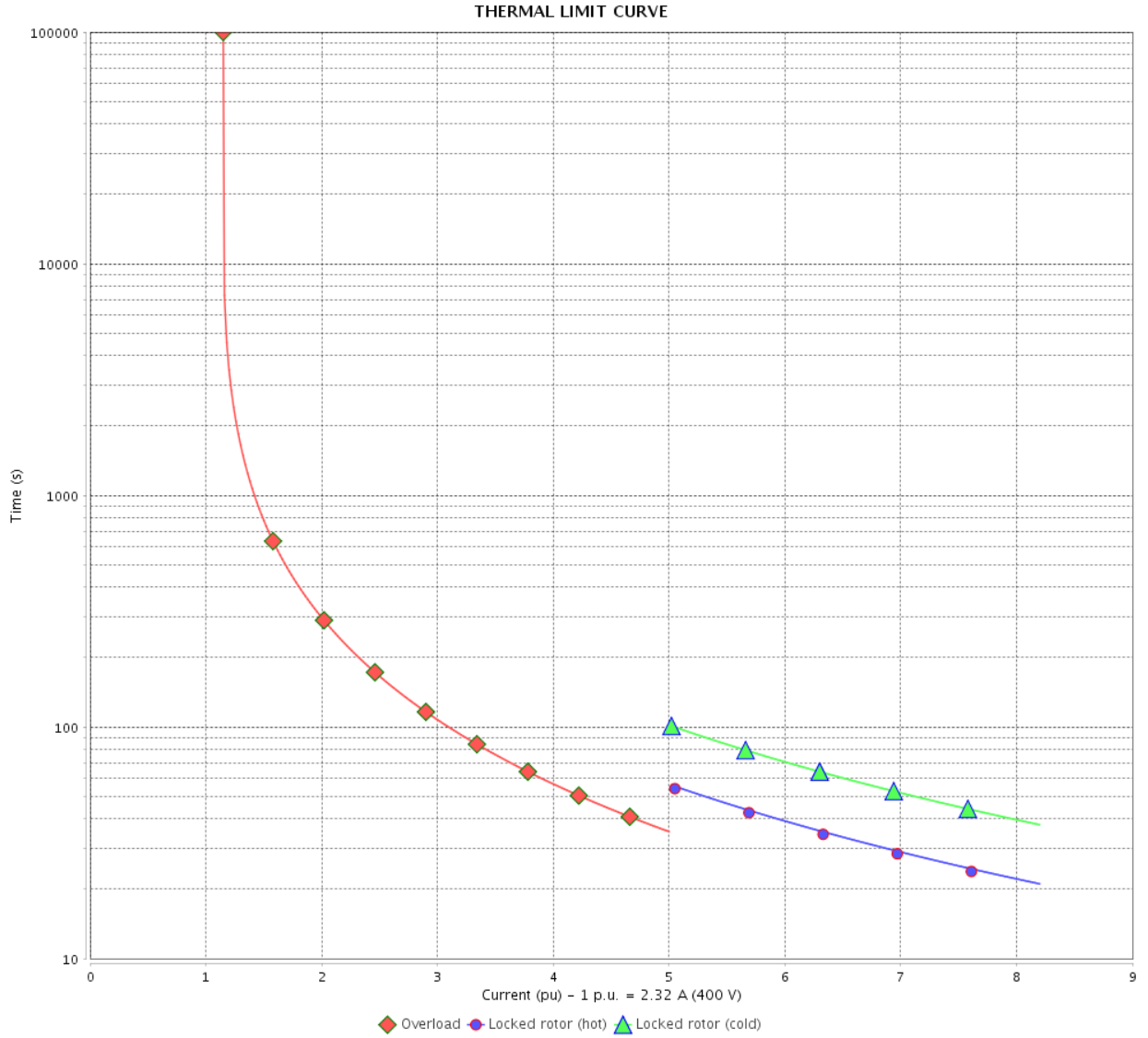

Rev.	Changes Summary	Performed	Checked	Date
Performed by				
Checked by				
Date				
			Page 5 / 6	Revision

# VFD OPERATION CURVE

Three Phase Induction Motor - Squirrel Cage



Customer : \_\_\_\_\_

Product line : JM Pump NEMA Premium Efficiency Three-Phase

Product code : 14808488

Catalog # : 00158ET3V145JM-S

VFD OPERATION CURVE

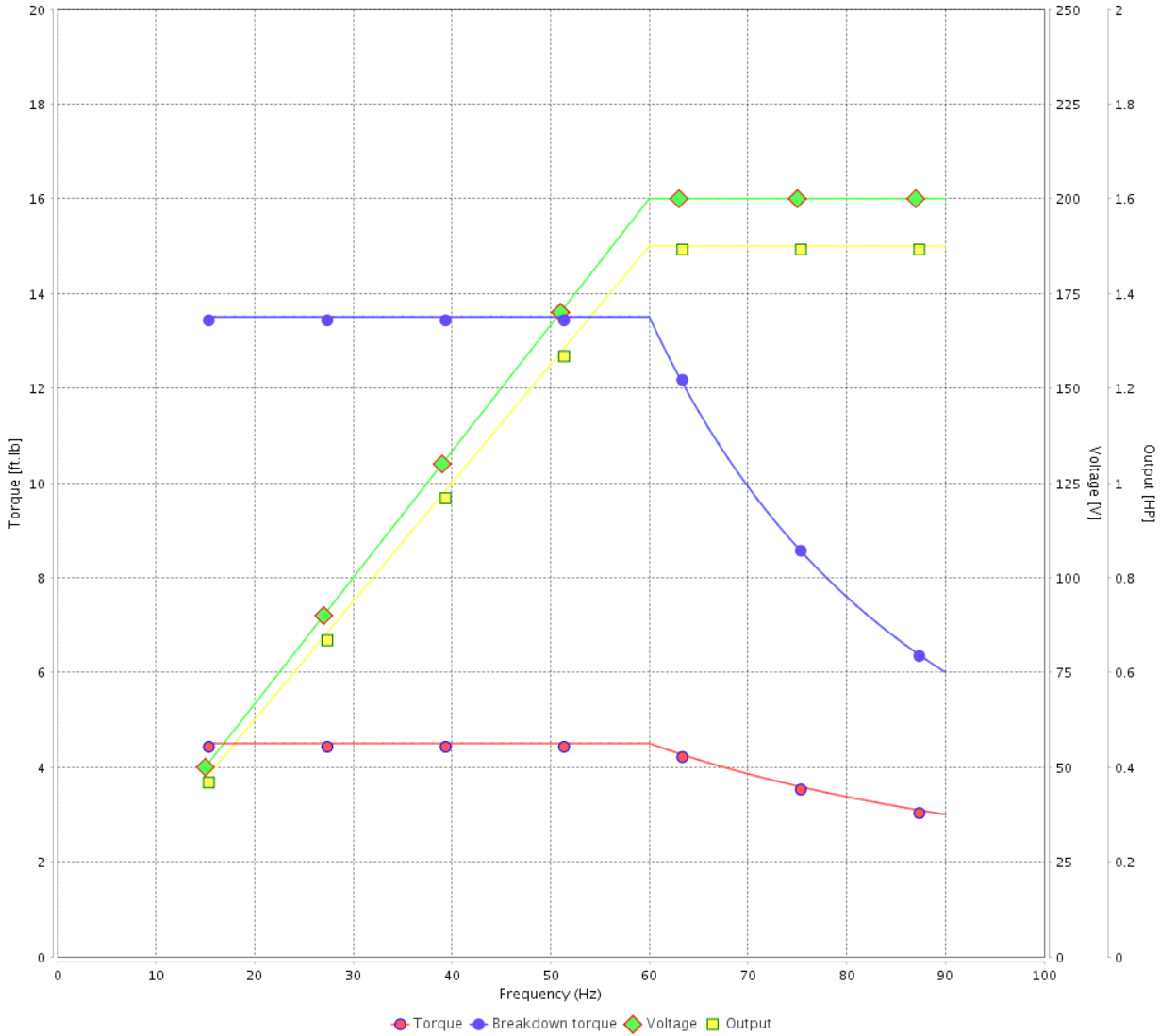

Performance : 200/400 V 60 Hz 4P

Rated current : 4.65/2.32 A  
 LRC : 8.2  
 Rated torque : 4.50 ft.lb  
 Locked rotor torque : 270 %  
 Breakdown torque : 300 %  
 Rated speed : 1750 rpm

Moment of inertia (J) : 0.1101 sq.ft.lb  
 Duty cycle : Cont.(S1)  
 Insulation class : F  
 Service factor : 1.15  
 Temperature rise : 80 K  
 Design : B

Rev.	Changes Summary	Performed	Checked	Date
Performed by			Page	Revision
Checked by				
Date				

1 2 3 4 5 6

A

B

C

D

E

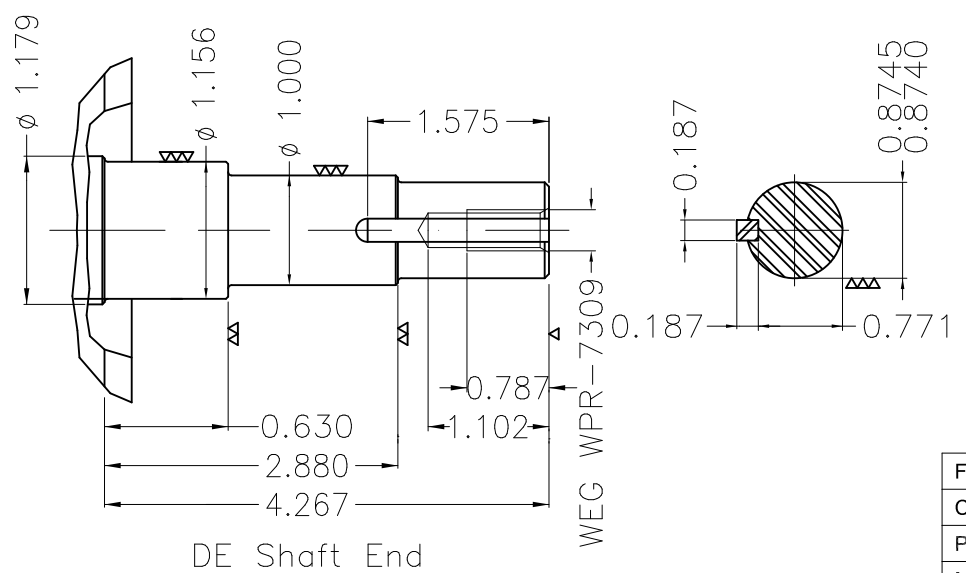
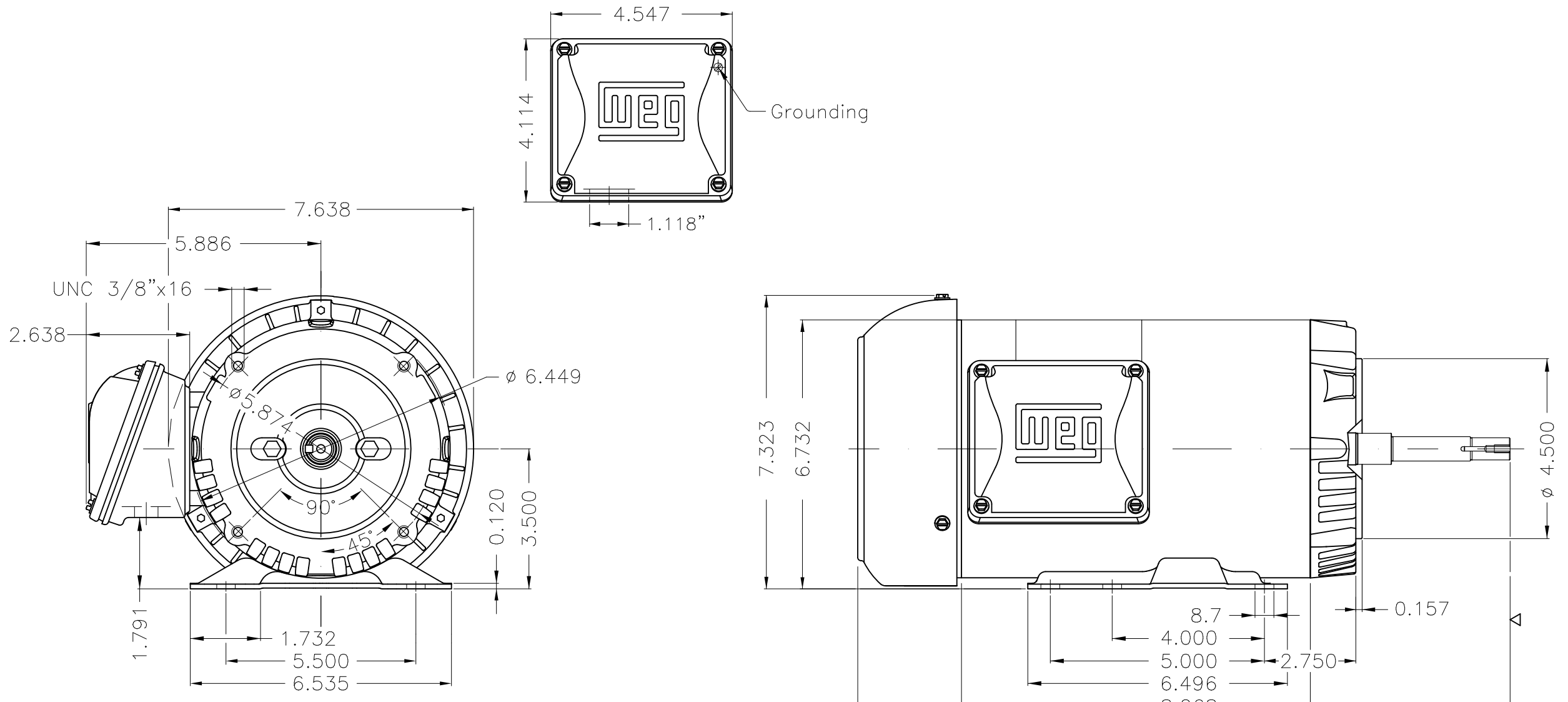

EUNC 3/8"-16 WEG WPR-7309

DE Shaft End

Fan cover - steel plate						
Color Munsell N 1 matte black						
Painting plan 207N						
Mounting F-1/B34R(D)						

ECM	LOC	SUMMARY OF MODIFICATIONS			EXECUTED	CHECKED	RELEASED	DATE	VER
EXECUTED	PIRBUSER		THREE PH. MOTOR ROLLED STEEL CLOSE COUPLED PUMP JN TYPE PSE 143						
CHECKED			FRAME 143/5JM IP55 TEFC						
RELEASED									
REL DT.		WMO	Jaragua do Sul	Product Engineering	SHEET	1 / 1			

1.5 HP 04 Poles 60 Hz

**NEMA  
Premium**3PT9  
US LISTED  
FOR SAFE AREA

Energy Verified

MADE IN MEXICO

**MAT: 14808488 CC029A****W01.TE0IC0X0N****MODEL 00158ET3V145JM-S****05AUG2021 B/N:****For 60Hz: Class I, Zone 2, IIC  
Class I, Div.2, Gr. A,B,C,D - T3****Div 2 Inverter Duty (SF1.00)  
CT 2:1/VT 1000:1**

<b>PH 3</b>	<b>Hz 60</b>	<b>HP 1.5</b>
<b>FR 143/5JM</b>		<b>KW 1.1</b>
<b>DUTY CONT.</b>		<b>V 200/400</b>
<b>ALT 1000 m.a.s.l.</b>		<b>A 4.65/2.32</b>
<b>INS CL F AT 80K</b>	<b>IP55</b>	<b>SFA 5.35/2.67</b>
<b>AMB 40°C</b>	<b>DES B</b>	<b>SF 1.15</b>
<b>ENCL TEFC</b>	<b>CODE K</b>	<b>PF 0.79</b>
		<b>RPM 1750</b>
		<b>NEMA NOM. EFF 86.5%</b>

**For safe area-inverter duty motor For use on VPWM 1000:1 VT, 4:1 CT**

<b>DE 6206-ZZ</b>	<b>ODE 6203-ZZ</b>	<b>MOBIL POLYREX EM</b>
-------------------	--------------------	-------------------------

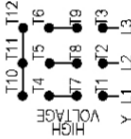
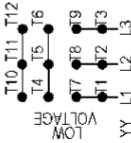

T1-BLU T2-WHT  
 T3-ORG T4-YEL  
 T5-BLK T6-GRY  
 T7-PNK T8-RED  
 T9-BRK RED  
 T10-CURRY  
 T11-GRN T12-VLT

**INTERCHANGE ANY TWO LINE WIRES TO REVERSE THE ROTATION**

**WARNING:** Motor must be grounded in accordance with local and national electrical codes to prevent serious electrical shocks. Disconnect power source before servicing unit.



**AVERTISSEMENT:** Le moteur doit être mis à la terre conformément aux codes électriques locaux et nationaux afin d'éviter tout choc électrique grave. Déconnectez l'alimentation avant l'entretien de la machine.

