

# DATA SHEET

## Three Phase Induction Motor - Squirrel Cage



Customer :				
Product line	: NEMA Premium Efficiency Three-Phase	Product code :	12708221	
		Catalog # :	00158OT3E145T-SG	
Frame	: 143/5T	Cooling method	: IC01 - ODP	
Insulation class	: F	Mounting	: F-1	
Duty cycle	: Cont.(S1)	Rotation <sup>1</sup>	: Both (CW and CCW)	
Ambient temperature	: -20°C to +40°C	Starting method	: Direct On Line	
Altitude	: 1000 m.a.s.l.	Approx. weight <sup>2</sup>	: 42.6 lb	
Design	: B	Moment of inertia (J)	: 0.1426 sq.ft.lb	
Output [HP]	1.5	1.5	1.5	
Poles	4	4	4	
Frequency [Hz]	60	50	50	
Rated voltage [V]	230/460	190/380	220/415	
Rated current [A]	4.14/2.07	4.84/2.42	4.41/2.34	
L. R. Amperes [A]	36.0/18.0	31.0/15.5	30.9/16.4	
LRC [A]	8.7x(Code L)	6.4x(Code H)	7.0x(Code J)	
No load current [A]	2.40/1.20	2.36/1.18	2.41/1.28	
Rated speed [RPM]	1760	1440	1445	
Slip [%]	2.22	4.00	3.67	
Rated torque [ft.lb]	4.48	5.47	5.45	
Locked rotor torque [%]	280	190	220	
Breakdown torque [%]	330	250	280	
Service factor		1.15	1.15	
Temperature rise	80 K	80 K	80 K	
Locked rotor time	27s (cold) 15s (hot)	0s (cold) 0s (hot)	0s (cold) 0s (hot)	
Noise level <sup>2</sup>	52.0 dB(A)	49.0 dB(A)	49.0 dB(A)	
Efficiency (%)	25%	83.6	84.0	
	50%	84.0	83.6	
	75%	86.5	84.8	
	100%	86.5	83.9	
Power Factor	25%	0.32	0.35	
	50%	0.56	0.60	
	75%	0.69	0.73	
	100%	0.77	0.81	
Bearing type	: <u>Drive end</u> 6205 ZZ <u>Non drive end</u> 6203 ZZ	Foundation loads		
Sealing	: Without Without Bearing Seal Bearing Seal	Max. traction	: 111 lb	
		Max. compression	: 154 lb	
Lubrication interval	: - -			
Lubricant amount	: - -			
Lubricant type	: Mobil Polyrex EM			
Notes USABLE @208V 4.58A SF 1.00 SFA 4.58A				
This revision replaces and cancel the previous one, which must be eliminated. (1) Looking the motor from the shaft end. (2) Measured at 1m and with tolerance of +3dB(A). (3) Approximate weight subject to changes after manufacturing process. (4) At 100% of full load.		These are average values based on tests with sinusoidal power supply, subject to the tolerances stipulated in NEMA MG-1.		
Rev.	Changes Summary	Performed	Checked	Date
Performed by				
Checked by			Page	Revision
Date	12/04/2022		1 / 16	

# TORQUE AND CURRENT VS SPEED CURVE

Three Phase Induction Motor - Squirrel Cage



Customer :

Product line : NEMA Premium Efficiency Three-Phase

Product code : 12708221

Catalog # : 00158OT3E145T-SG

TORQUE AND CURRENT VS SPEED CURVE

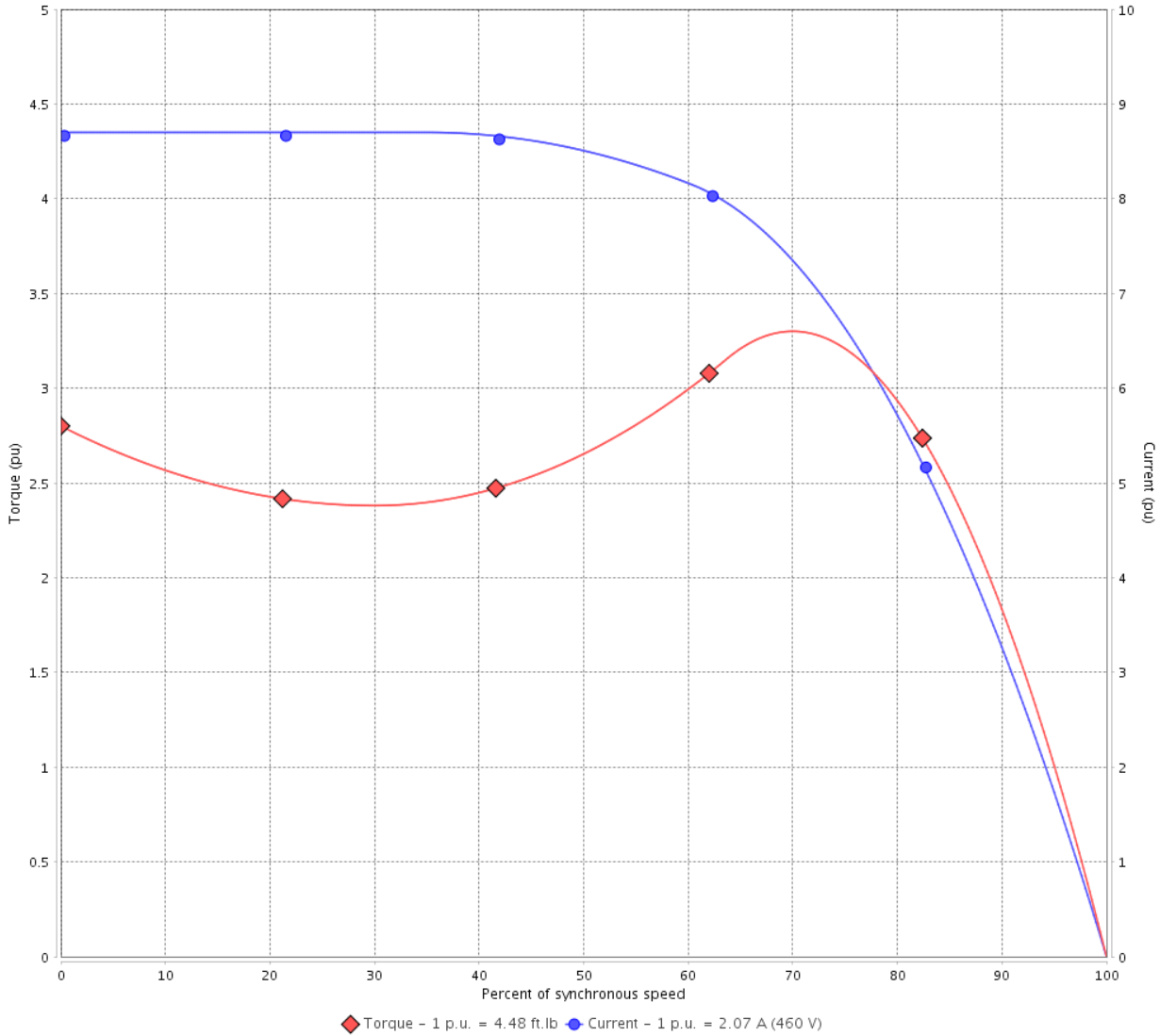

Performance : 230/460 V 60 Hz 4P

Rated current	: 4.14/2.07 A	Moment of inertia (J)	: 0.1426 sq.ft.lb
LRC	: 8.7	Duty cycle	: Cont.(S1)
Rated torque	: 4.48 ft.lb	Insulation class	: F
Locked rotor torque	: 280 %	Service factor	:
Breakdown torque	: 330 %	Temperature rise	: 80 K
Rated speed	: 1760 rpm	Design	: B

Locked rotor time : 27s (cold) 15s (hot)

Rev.	Changes Summary	Performed	Checked	Date
Performed by			Page 2 / 16	Revision
Checked by				
Date	12/04/2022			

# TORQUE AND CURRENT VS SPEED CURVE



## Three Phase Induction Motor - Squirrel Cage

Customer :

Product line : NEMA Premium Efficiency Three-Phase

Product code : 12708221

Catalog # : 00158OT3E145T-SG

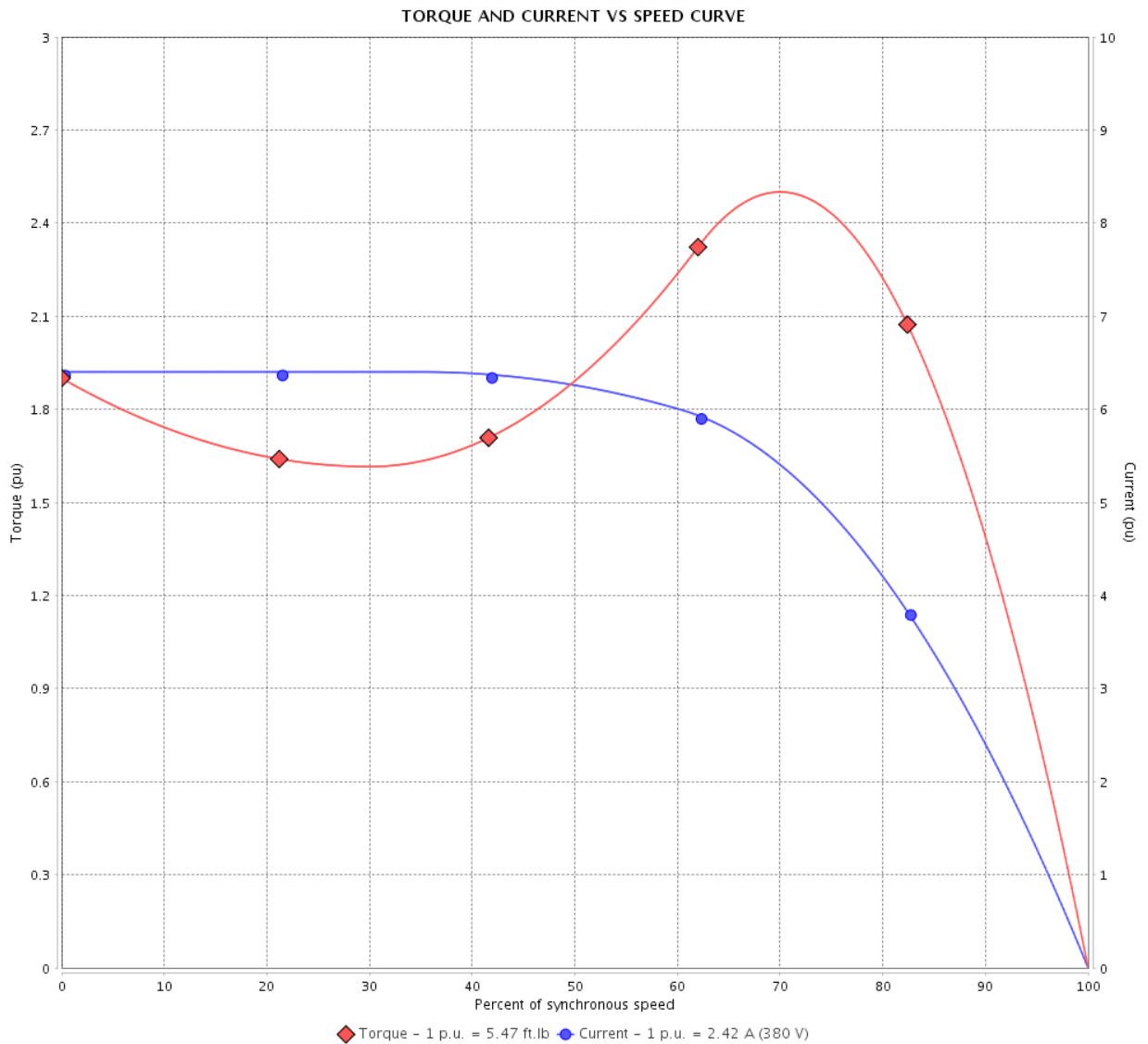

Performance : 190/380 V 50 Hz 4P

Rated current	: 4.84/2.42 A	Moment of inertia (J)	: 0.1426 sq.ft.lb
LRC	: 6.4	Duty cycle	: Cont.(S1)
Rated torque	: 5.47 ft.lb	Insulation class	: F
Locked rotor torque	: 190 %	Service factor	: 1.15
Breakdown torque	: 250 %	Temperature rise	: 80 K
Rated speed	: 1440 rpm	Design	: B

Locked rotor time : 0s (cold) 0s (hot)

Rev.	Changes Summary	Performed	Checked	Date
Performed by			Page 3 / 16	Revision
Checked by				
Date	12/04/2022			

# TORQUE AND CURRENT VS SPEED CURVE

Three Phase Induction Motor - Squirrel Cage



Customer :

Product line : NEMA Premium Efficiency Three-Phase

Product code : 12708221

Catalog # : 00158OT3E145T-SG

TORQUE AND CURRENT VS SPEED CURVE

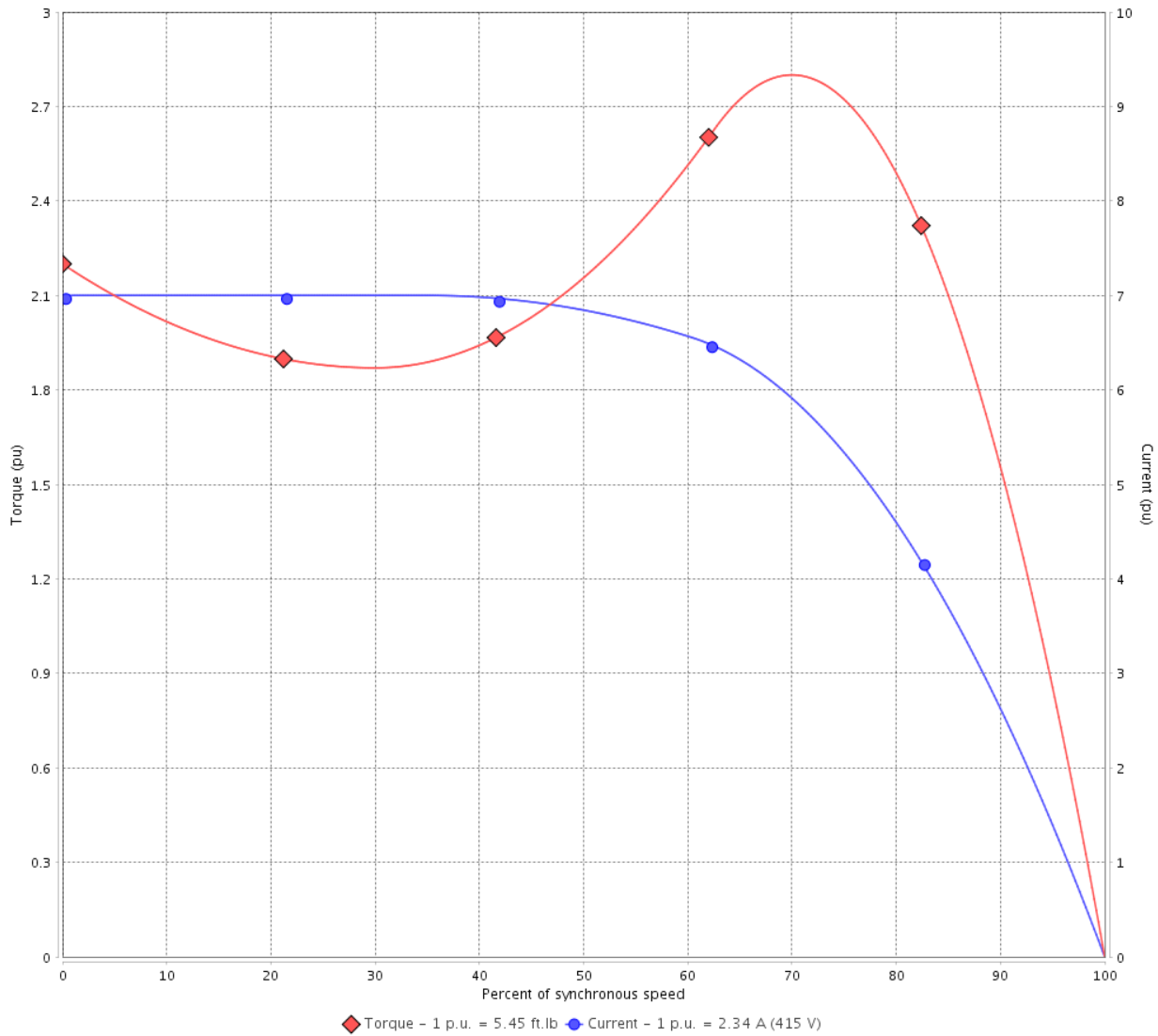

Performance : 220/415 V 50 Hz 4P

Rated current	: 4.41/2.34 A	Moment of inertia (J)	: 0.1426 sq.ft.lb
LRC	: 7.0	Duty cycle	: Cont.(S1)
Rated torque	: 5.45 ft.lb	Insulation class	: F
Locked rotor torque	: 220 %	Service factor	: 1.15
Breakdown torque	: 280 %	Temperature rise	: 80 K
Rated speed	: 1445 rpm	Design	: B

Locked rotor time : 0s (cold) 0s (hot)

Rev.	Changes Summary	Performed	Checked	Date
Performed by			Page 4 / 16	Revision
Checked by				
Date	12/04/2022			

# LOAD PERFORMANCE CURVE

## Three Phase Induction Motor - Squirrel Cage



Customer :

Product line : NEMA Premium Efficiency Three-Phase

Product code : 12708221

Catalog # : 00158OT3E145T-SG

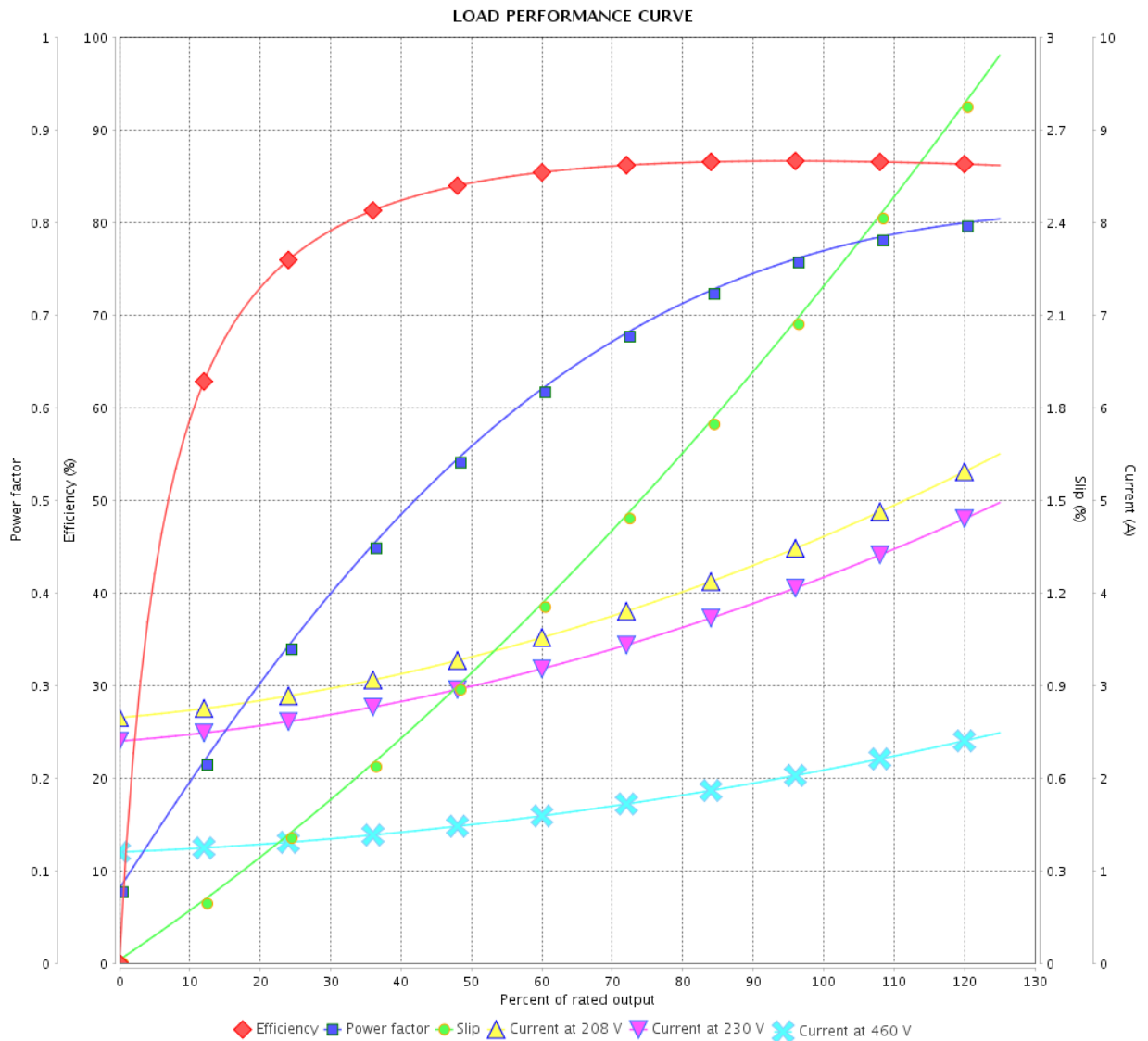

Performance : 230/460 V 60 Hz 4P

Rated current : 4.14/2.07 A  
 LRC : 8.7  
 Rated torque : 4.48 ft.lb  
 Locked rotor torque : 280 %  
 Breakdown torque : 330 %  
 Rated speed : 1760 rpm

Moment of inertia (J) : 0.1426 sq.ft.lb  
 Duty cycle : Cont.(S1)  
 Insulation class : F  
 Service factor :  
 Temperature rise : 80 K  
 Design : B

Rev.	Changes Summary	Performed	Checked	Date
Performed by			Page	Revision
Checked by			5 / 16	
Date	12/04/2022			

# LOAD PERFORMANCE CURVE

Three Phase Induction Motor - Squirrel Cage



Customer :

Product line : NEMA Premium Efficiency Three-Phase

Product code : 12708221

Catalog # : 00158OT3E145T-SG

LOAD PERFORMANCE CURVE

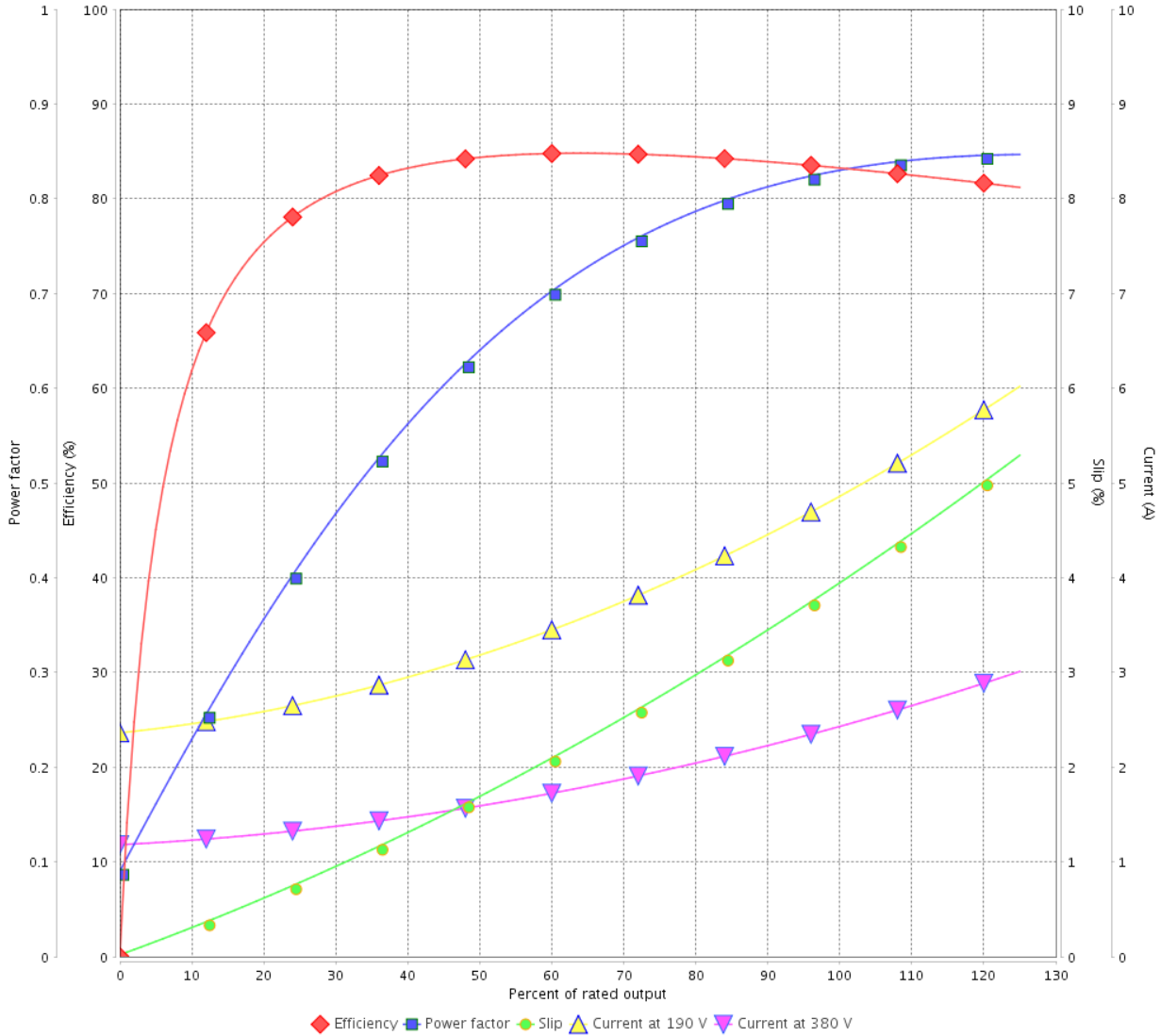

Performance : 190/380 V 50 Hz 4P

Rated current : 4.84/2.42 A  
 LRC : 6.4  
 Rated torque : 5.47 ft.lb  
 Locked rotor torque : 190 %  
 Breakdown torque : 250 %  
 Rated speed : 1440 rpm

Moment of inertia (J) : 0.1426 sq.ft.lb  
 Duty cycle : Cont.(S1)  
 Insulation class : F  
 Service factor : 1.15  
 Temperature rise : 80 K  
 Design : B

Rev.	Changes Summary	Performed	Checked	Date
Performed by			Page	Revision
Checked by			6 / 16	
Date	12/04/2022			

# LOAD PERFORMANCE CURVE

## Three Phase Induction Motor - Squirrel Cage



Customer :

Product line : NEMA Premium Efficiency Three-Phase

Product code : 12708221

Catalog # : 00158OT3E145T-SG

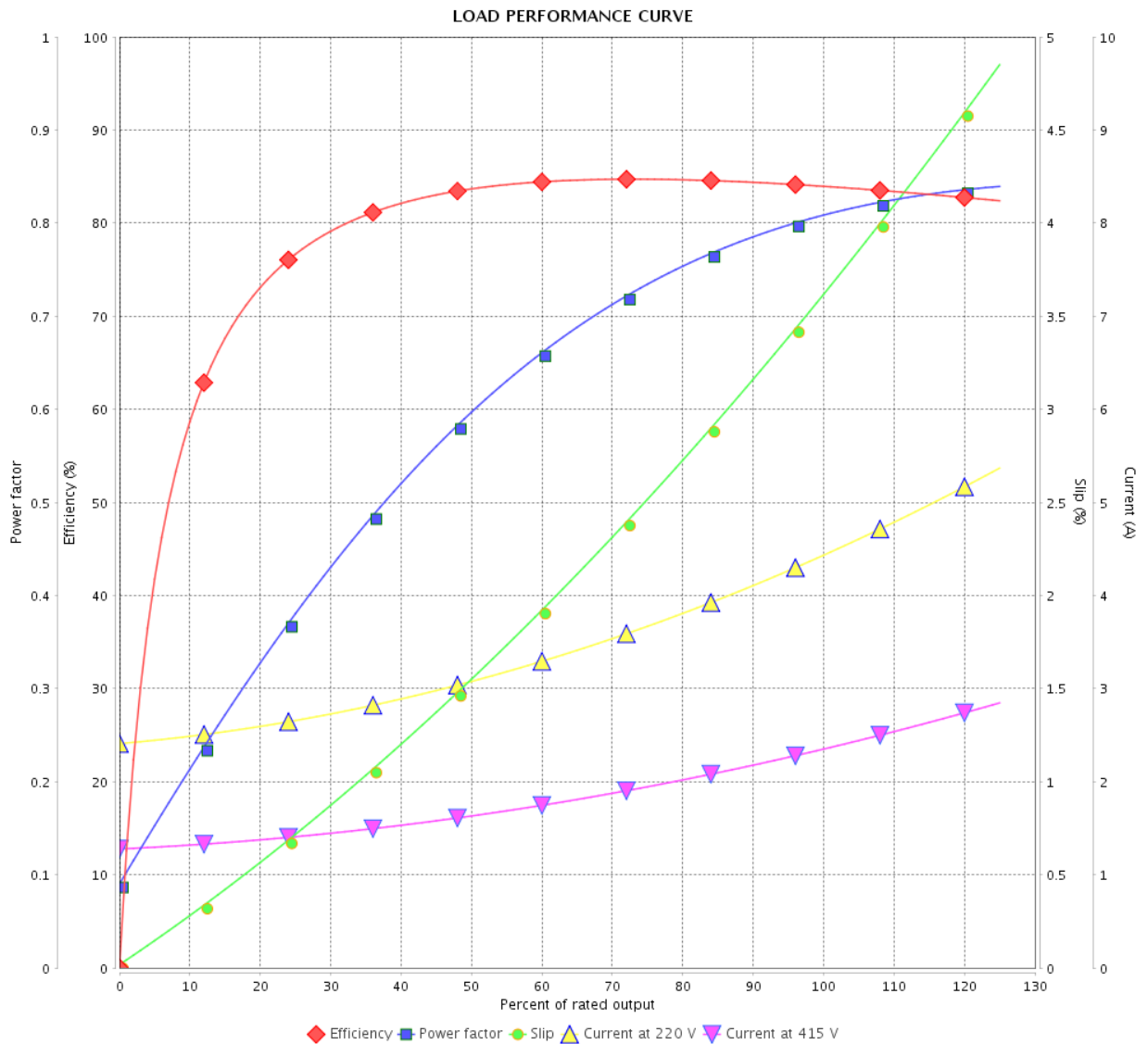

Performance : 220/415 V 50 Hz 4P

Rated current : 4.41/2.34 A  
 LRC : 7.0  
 Rated torque : 5.45 ft.lb  
 Locked rotor torque : 220 %  
 Breakdown torque : 280 %  
 Rated speed : 1445 rpm

Moment of inertia (J) : 0.1426 sq.ft.lb  
 Duty cycle : Cont.(S1)  
 Insulation class : F  
 Service factor : 1.15  
 Temperature rise : 80 K  
 Design : B

Rev.	Changes Summary	Performed	Checked	Date
Performed by			Page	Revision
Checked by			7 / 16	
Date	12/04/2022			

# THERMAL LIMIT CURVE



## Three Phase Induction Motor - Squirrel Cage

Customer :

Product line : NEMA Premium Efficiency Three-Phase  
 Product code : 12708221  
 Catalog # : 00158OT3E145T-SG

Performance : 230/460 V 60 Hz 4P

Rated current : 4.14/2.07 A	Moment of inertia (J) : 0.1426 sq.ft.lb
LRC : 8.7	Duty cycle : Cont.(S1)
Rated torque : 4.48 ft.lb	Insulation class : F
Locked rotor torque : 280 %	Service factor :
Breakdown torque : 330 %	Temperature rise : 80 K
Rated speed : 1760 rpm	Design : B

Heating constant

Cooling constant

Rev.	Changes Summary	Performed	Checked	Date
Performed by			Page	Revision
Checked by				
Date	12/04/2022			



# THERMAL LIMIT CURVE

Three Phase Induction Motor - Squirrel Cage



Customer : \_\_\_\_\_

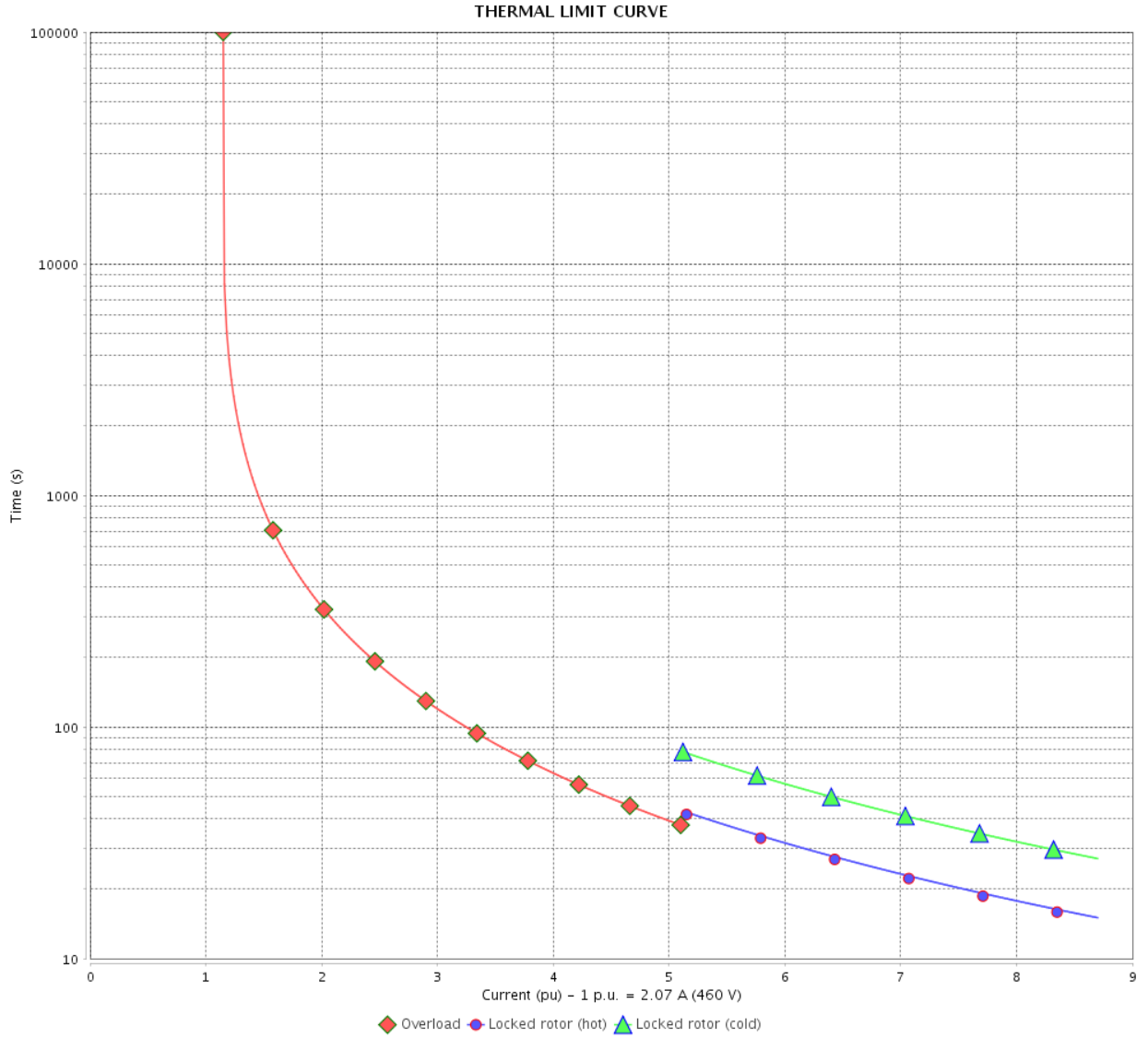

Rev.	Changes Summary	Performed	Checked	Date
Performed by			Page	Revision
Checked by				
Date				
			9 / 16	

# THERMAL LIMIT CURVE



## Three Phase Induction Motor - Squirrel Cage

Customer :

Product line : NEMA Premium Efficiency Three-Phase  
 Product code : 12708221  
 Catalog # : 00158OT3E145T-SG

Performance : 190/380 V 50 Hz 4P

Rated current : 4.84/2.42 A	Moment of inertia (J) : 0.1426 sq.ft.lb
LRC : 6.4	Duty cycle : Cont.(S1)
Rated torque : 5.47 ft.lb	Insulation class : F
Locked rotor torque : 190 %	Service factor : 1.15
Breakdown torque : 250 %	Temperature rise : 80 K
Rated speed : 1440 rpm	Design : B

Heating constant

Cooling constant

Rev.	Changes Summary	Performed	Checked	Date
Performed by			Page 10 / 16	Revision
Checked by				
Date	12/04/2022			

# THERMAL LIMIT CURVE

Three Phase Induction Motor - Squirrel Cage



Customer : \_\_\_\_\_

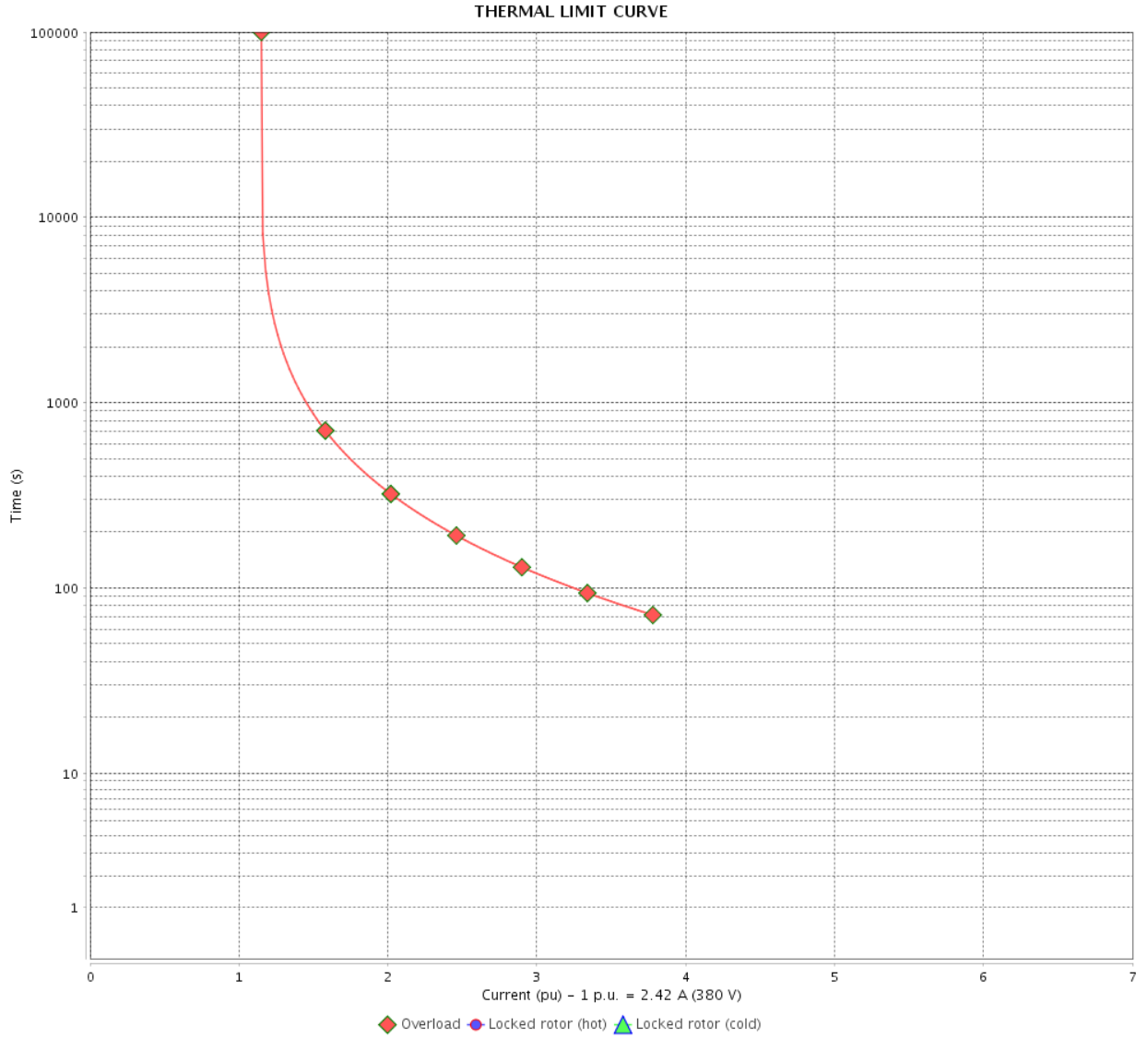

Rev.	Changes Summary	Performed	Checked	Date
Performed by		Page		Revision
Checked by		11 / 16		
Date		12/04/2022		

# THERMAL LIMIT CURVE



## Three Phase Induction Motor - Squirrel Cage

Customer :

Product line : NEMA Premium Efficiency Three-Phase  
Product code : 12708221  
Catalog # : 00158OT3E145T-SG

Performance : 220/415 V 50 Hz 4P

Rated current	: 4.41/2.34 A	Moment of inertia (J)	: 0.1426 sq.ft.lb
LRC	: 7.0	Duty cycle	: Cont.(S1)
Rated torque	: 5.45 ft.lb	Insulation class	: F
Locked rotor torque	: 220 %	Service factor	: 1.15
Breakdown torque	: 280 %	Temperature rise	: 80 K
Rated speed	: 1445 rpm	Design	: B

Heating constant

Cooling constant

Rev.	Changes Summary	Performed	Checked	Date
Performed by				
Checked by			Page	Revision
Date	12/04/2022		12 / 16	

# THERMAL LIMIT CURVE

Three Phase Induction Motor - Squirrel Cage



Customer : \_\_\_\_\_

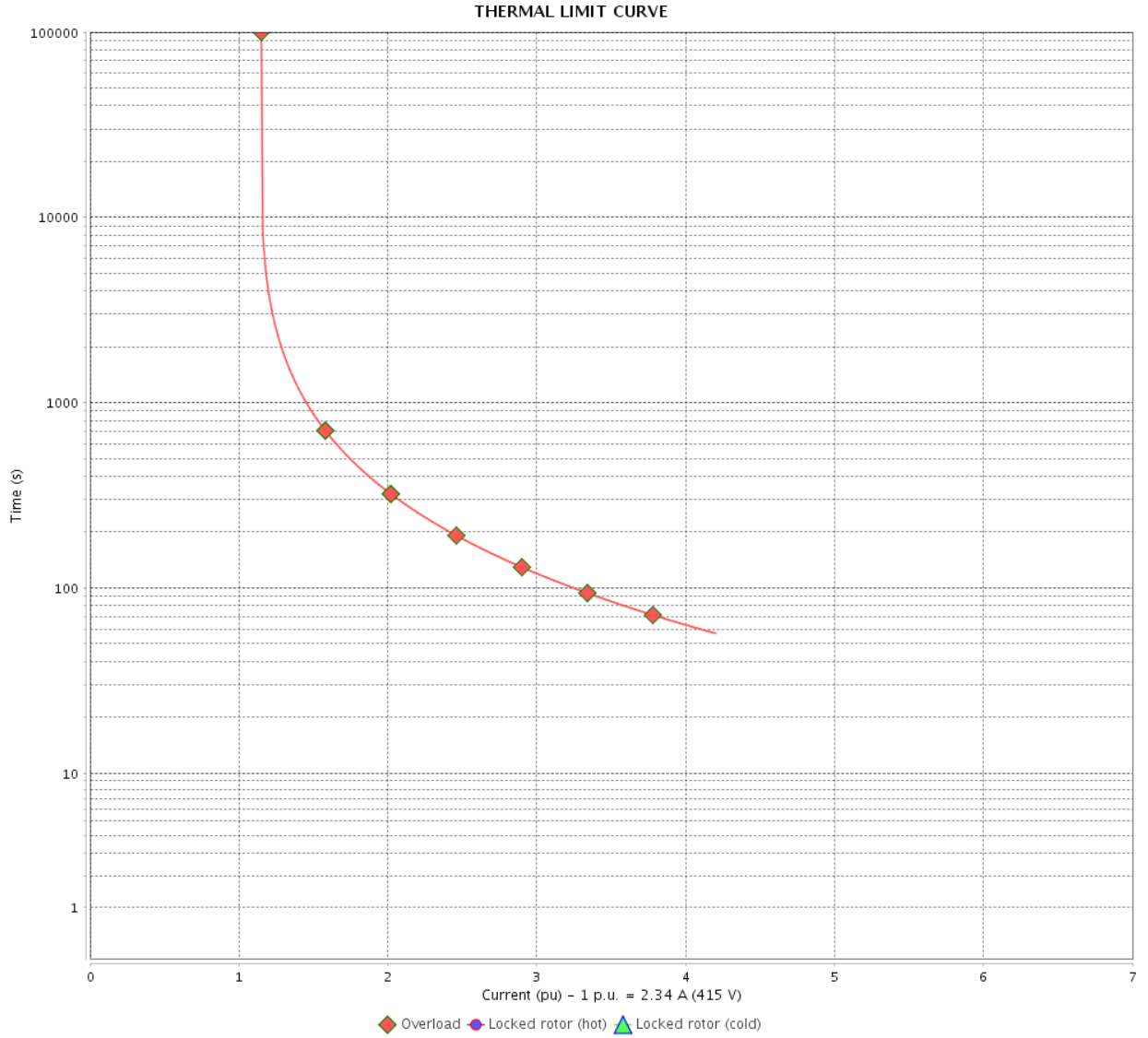

Rev.	Changes Summary	Performed	Checked	Date
Performed by		Page		Revision
Checked by		13 / 16		
Date		12/04/2022		

# VFD OPERATION CURVE

Three Phase Induction Motor - Squirrel Cage



Customer :

Product line : NEMA Premium Efficiency Three-Phase

Product code : 12708221

Catalog # : 00158OT3E145T-SG

VFD OPERATION CURVE

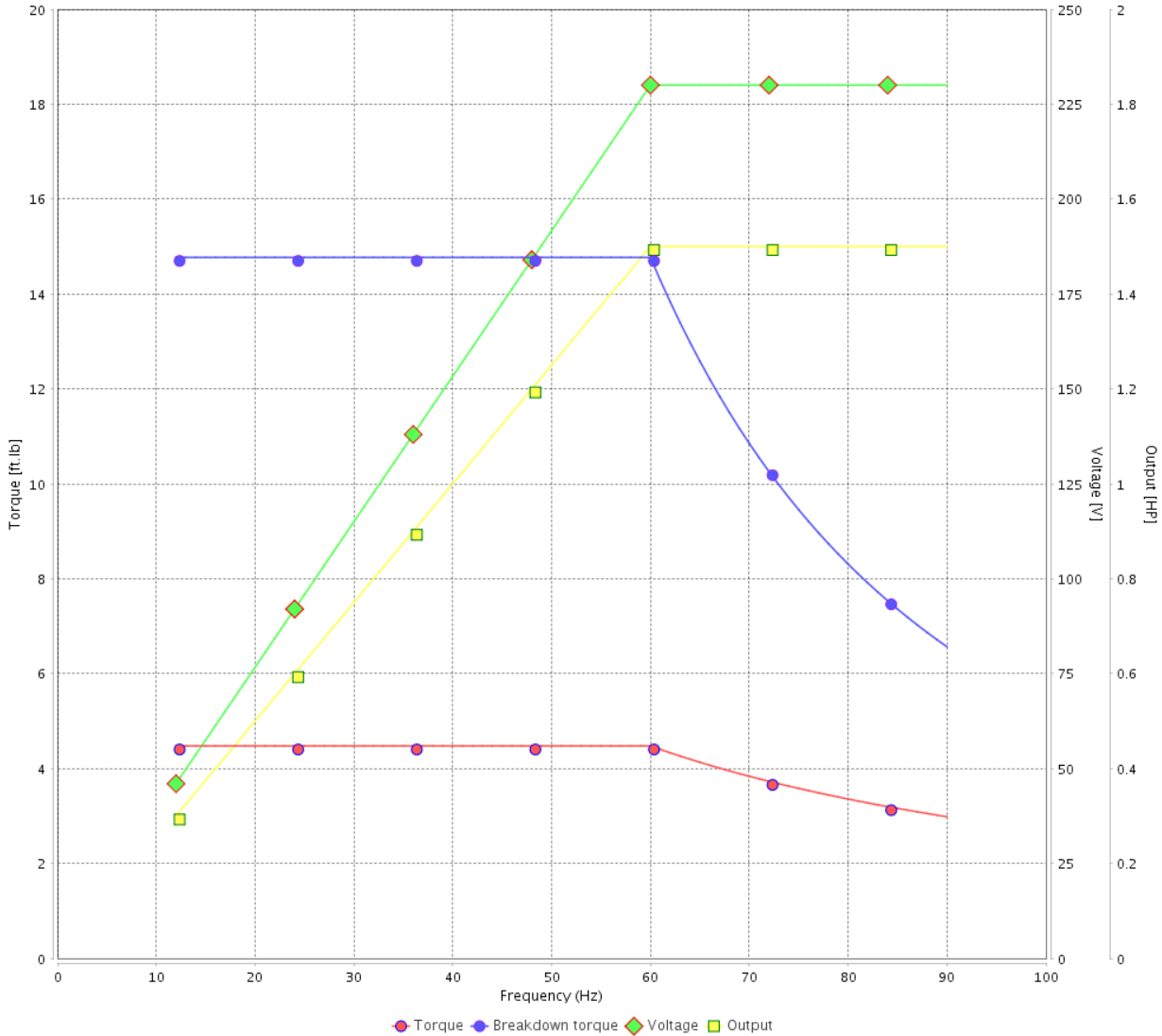

Performance : 230/460 V 60 Hz 4P

Rated current : 4.14/2.07 A  
 LRC : 8.7  
 Rated torque : 4.48 ft.lb  
 Locked rotor torque : 280 %  
 Breakdown torque : 330 %  
 Rated speed : 1760 rpm

Moment of inertia (J) : 0.1426 sq.ft.lb  
 Duty cycle : Cont.(S1)  
 Insulation class : F  
 Service factor :  
 Temperature rise : 80 K  
 Design : B

Rev.	Changes Summary	Performed	Checked	Date
Performed by			Page 14 / 16	Revision
Checked by				
Date	12/04/2022			

# VFD OPERATION CURVE

## Three Phase Induction Motor - Squirrel Cage



Customer :

Product line : NEMA Premium Efficiency Three-Phase

Product code : 12708221

Catalog # : 00158OT3E145T-SG

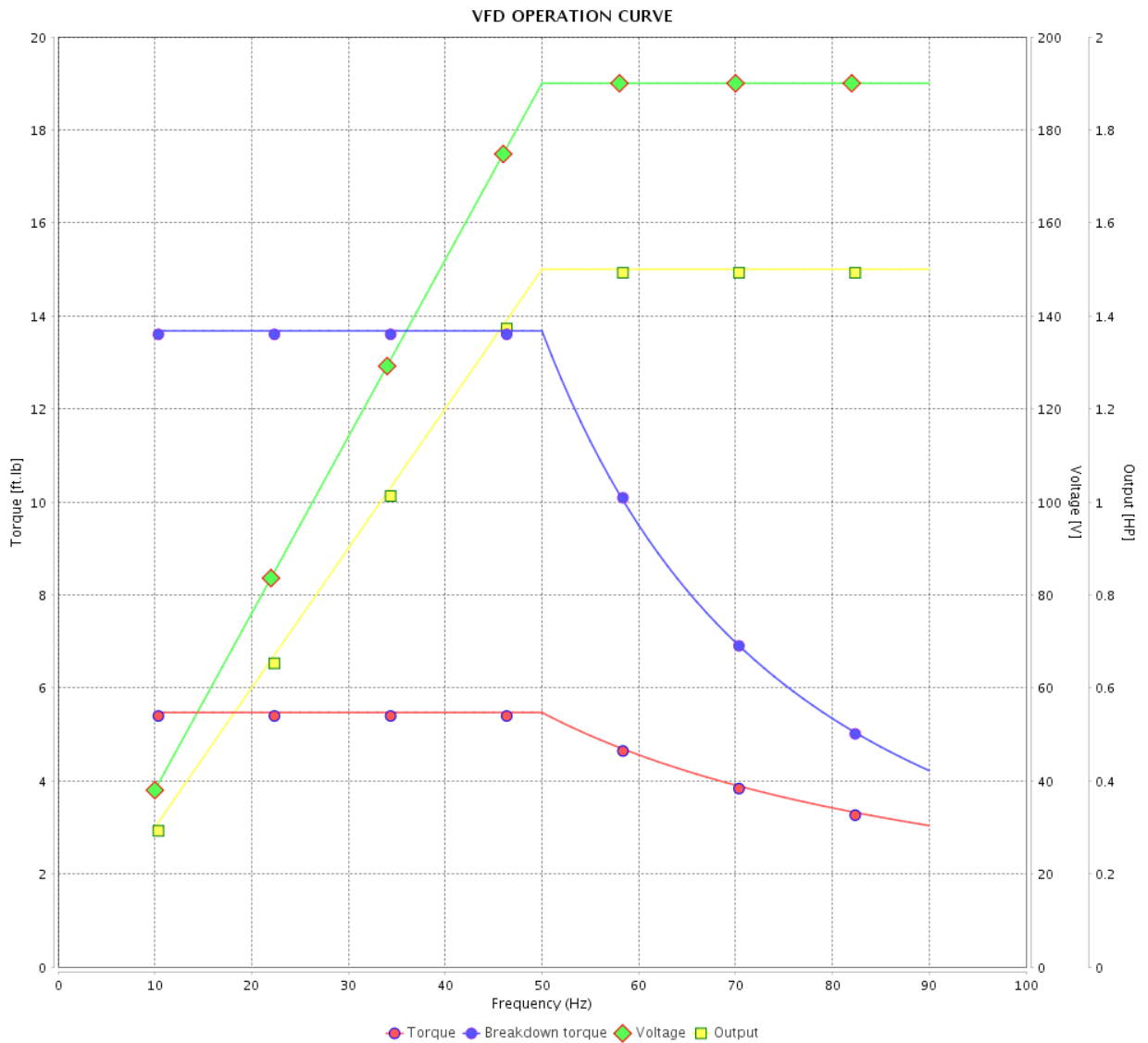

Performance : 190/380 V 50 Hz 4P

Rated current : 4.84/2.42 A  
 LRC : 6.4  
 Rated torque : 5.47 ft.lb  
 Locked rotor torque : 190 %  
 Breakdown torque : 250 %  
 Rated speed : 1440 rpm

Moment of inertia (J) : 0.1426 sq.ft.lb  
 Duty cycle : Cont.(S1)  
 Insulation class : F  
 Service factor : 1.15  
 Temperature rise : 80 K  
 Design : B

Rev.	Changes Summary	Performed	Checked	Date
Performed by			Page 15 / 16	Revision
Checked by				
Date	12/04/2022			

# VFD OPERATION CURVE

Three Phase Induction Motor - Squirrel Cage



Customer :

Product line : NEMA Premium Efficiency Three-Phase

Product code : 12708221

Catalog # : 00158OT3E145T-SG

VFD OPERATION CURVE

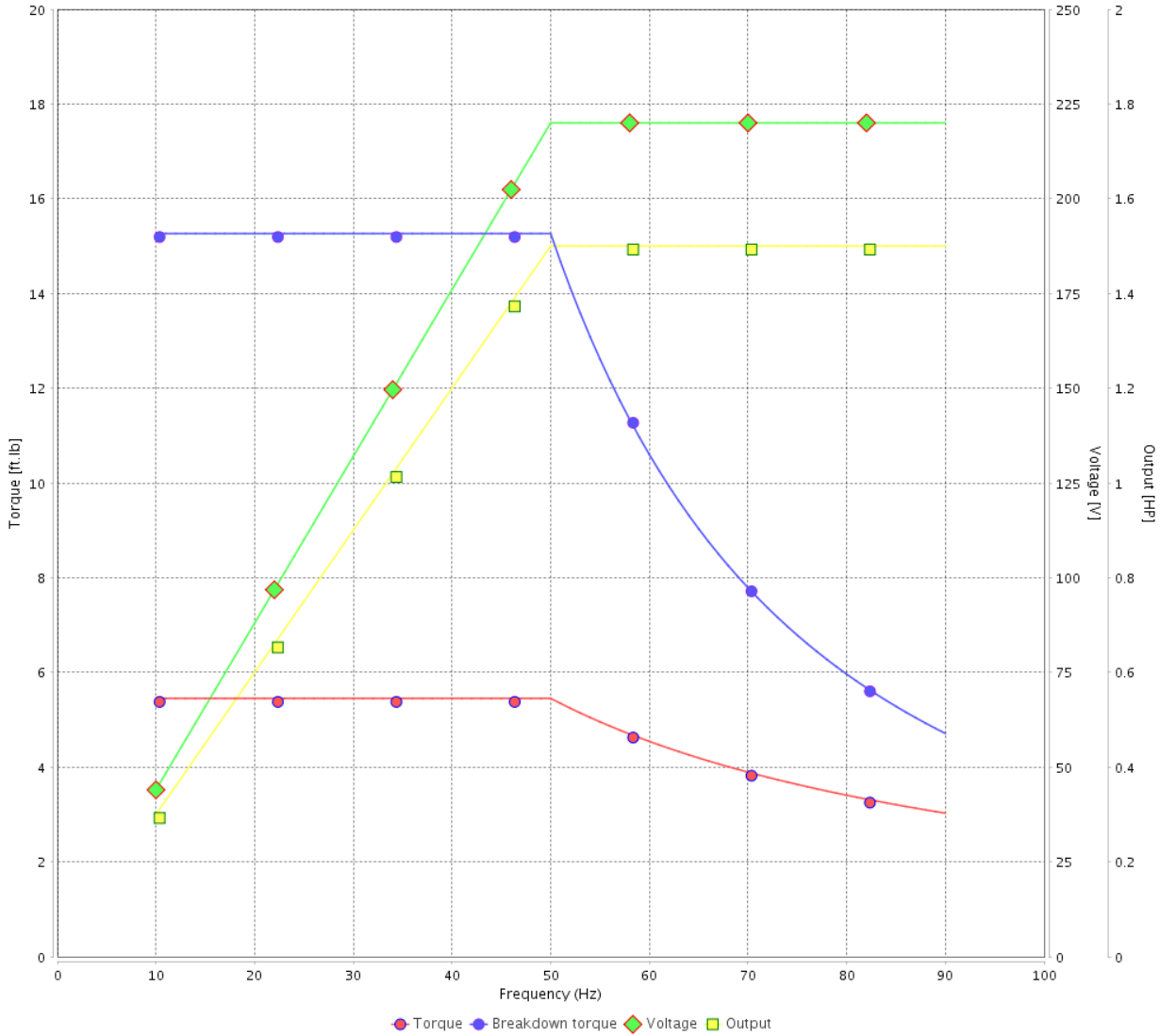

Performance : 220/415 V 50 Hz 4P

Rated current : 4.41/2.34 A  
 LRC : 7.0  
 Rated torque : 5.45 ft.lb  
 Locked rotor torque : 220 %  
 Breakdown torque : 280 %  
 Rated speed : 1445 rpm

Moment of inertia (J) : 0.1426 sq.ft.lb  
 Duty cycle : Cont.(S1)  
 Insulation class : F  
 Service factor : 1.15  
 Temperature rise : 80 K  
 Design : B

Rev.	Changes Summary	Performed	Checked	Date
Performed by			Page	Revision
Checked by				
Date				



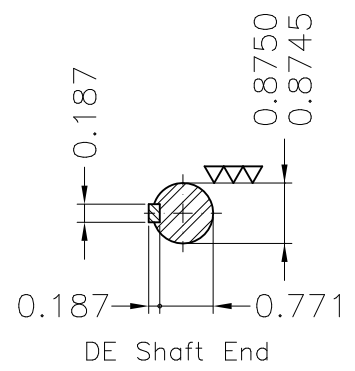
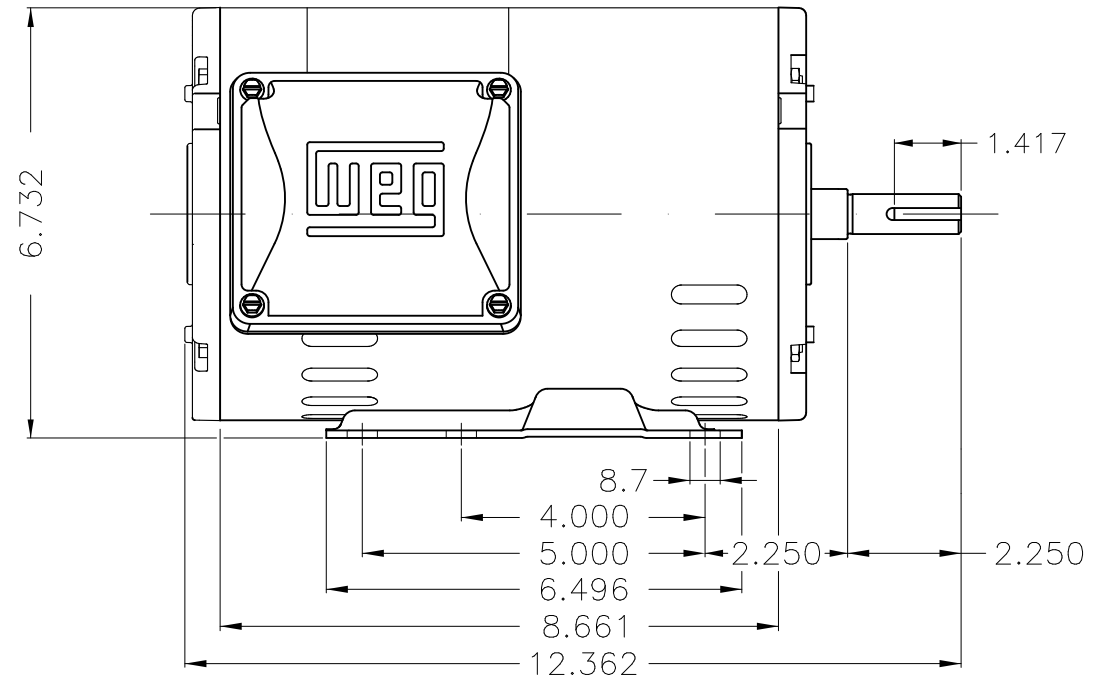
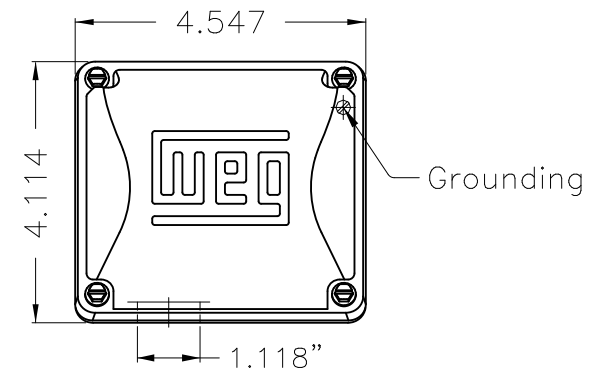
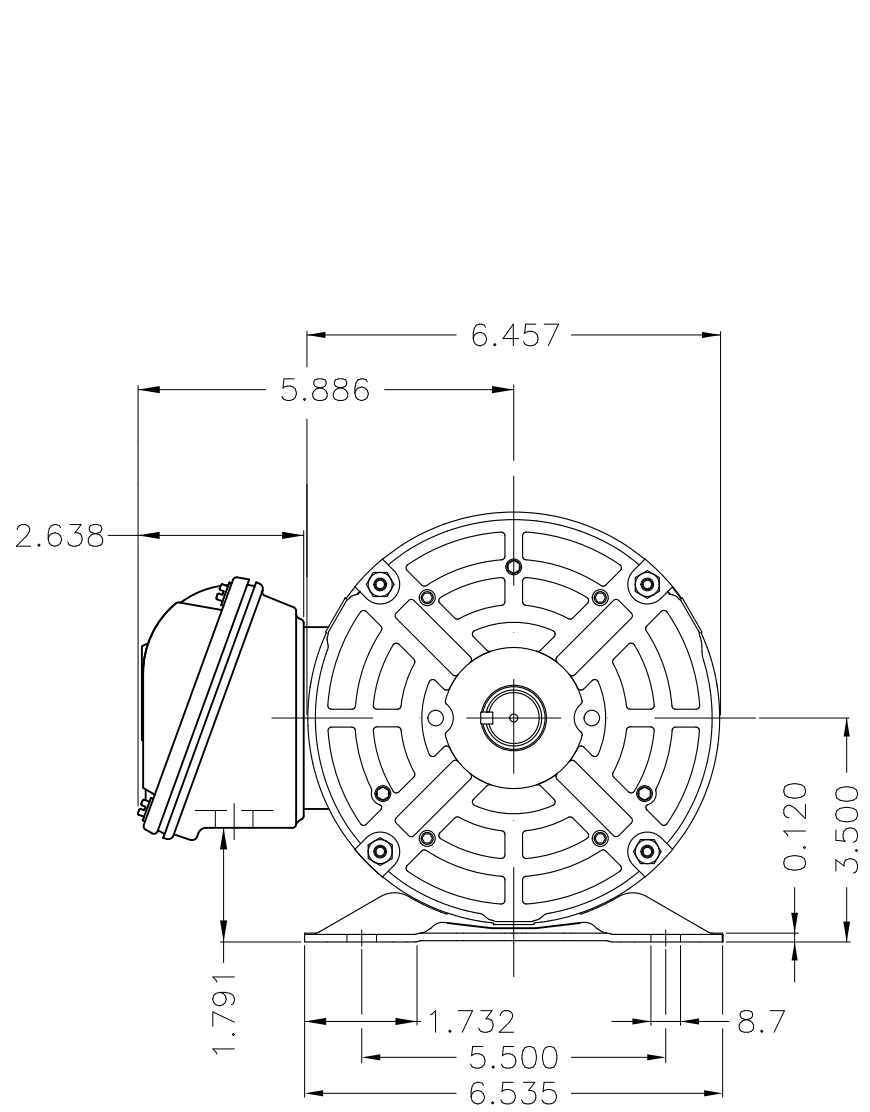

1 2 3 4 5 6

A  
B  
C  
D  
E

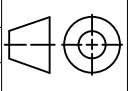

Bearing cap  
 Internal AEGIS ground ring on the DE  
 Color Munsell N 1 matte black  
 Painting plan 207N  
 Mounting F-1/B3R(D)

ECM	LOC	SUMMARY OF MODIFICATIONS	EXECUTED	CHECKED	RELEASED	DATE	VER
EXECUTED	PIRWBUSER	 THREE PH. MOTOR ROLLED STEEL PREM. EFF. FRAME 143/5T IP21 ODP					
CHECKED							
RELEASED							
REL DT.	WMO	Jaragua do Sul	Product Engineering	SHEET 1 / 1		PREVIEW WDD 	

1.5 HP 04 Poles 60 Hz

Dimensions in inches XME A3

**NEMA  
Premium**

MADE IN MEXICO

**MAT: 12708221 CC029A****W01.T00IC0X0N****MODEL 001580T3E145T-SG****21JAN2022 B/N:**

<b>PH 3</b>	<b>Hz 60</b>	<b>HP 1.5</b>
<b>FR 143/5T</b>		<b>KW 1.1</b>
<b>DUTY CONT.</b>		<b>V 230/460</b>
<b>ALT 1000 m.a.s.l.</b>		<b>A 4.14/2.07</b>
<b>INS CL F AT 80K</b>		<b>SFA 4.76/2.38</b>
<b>AMB 40°C</b>	<b>DES B</b>	<b>SF 1.15</b>
<b>ENCL ODP</b>	<b>CODE L</b>	<b>PF 0.77</b>
<b>USABLE @ 208V 4.58A</b>		<b>RPM 1760</b>
<b>SF1.00</b>		<b>NEMA NOM. EFF 86.5%</b>

<b>ALTERNATE RATING: 1.5HP 50Hz 190-220/380-415V SF1.15</b>
<b>4.84-4.34/2.42-2.30A 1440RPM EFF 83.2% (IE2) IEC 60034-1</b>

Inverter duty motor For 80Hz use on VPWM 1000:1 VT, 5:1 CT

<b>DE 6205-ZZ</b>	<b>ODE 6203-ZZ</b>	<b>MOBIL POLYREX EM</b>
-------------------	--------------------	-------------------------



T1-BLU T2-WHT  
 T3-ORG T4-YEL  
 T5-BLK T6-GRY  
 T7-PNK T8-RED  
 T9-BRK RED

**INTERCHANGE ANY TWO LINE WIRES TO REVERSE THE ROTATION**

**WARNING:** Motor must be grounded in accordance with local and national electrical codes to prevent serious electrical shocks. Disconnect power source before servicing unit.



**AVERTISSEMENT:** Le moteur doit être mis à la terre conformément aux codes électriques locaux et nationaux afin d'éviter tout choc électrique grave. Déconnectez l'alimentation avant l'entretien de la machine.

