

DATA SHEET

Three Phase Induction Motor - Squirrel Cage



Customer :					
Product line	: NEMA Premium Efficiency Three-Phase	Product code :	14293169		
		Catalog # :	00158XT3ER145TC		
Frame	: 143/5TC	Cooling method	: IC411 - TEFC		
Insulation class	: F	Mounting	: W-6		
Duty cycle	: Cont.(S1)	Rotation ¹	: Both (CW and CCW)		
Ambient temperature	: -20°C to +40°C	Starting method	: Direct On Line		
Altitude	: 1000 m.a.s.l.	Approx. weight ²	: 73.5 lb		
Protection degree	: IP55	Moment of inertia (J)	: 0.1303 sq.ft.lb		
Design	: B				
Output [HP]	1.5	1.5	1.5	1.5	
Poles	4	4	4	4	
Frequency [Hz]	60	50	50	50	
Rated voltage [V]	230/460	380	400	415	
Rated current [A]	4.10/2.05	2.40	2.33	2.27	
L. R. Amperes [A]	36.5/18.2	15.8	16.8	17.5	
LRC [A]	8.9x(Code L)	6.6x(Code H)	7.2x(Code J)	7.7x(Code K)	
No load current [A]	2.40/1.20	1.20	1.30	1.40	
Rated speed [RPM]	1755	1440	1445	1450	
Slip [%]	2.50	4.00	3.67	3.33	
Rated torque [ft.lb]	4.49	5.47	5.45	5.43	
Locked rotor torque [%]	270	200	229	250	
Breakdown torque [%]	350	260	290	320	
Service factor	1.15	1.00	1.00	1.00	
Temperature rise	80 K	80 K	80 K	80 K	
Locked rotor time	25s (cold) 14s (hot)	27s (cold) 15s (hot)	27s (cold) 15s (hot)	27s (cold) 15s (hot)	
Noise level ²	51.0 dB(A)	49.0 dB(A)	49.0 dB(A)	49.0 dB(A)	
Efficiency (%)	25%	80.2	83.7	83.7	80.9
	50%	81.5	84.0	84.0	82.5
	75%	85.5	84.0	84.0	84.0
	100%	86.5	84.0	84.0	85.5
Power Factor	25%	0.34	0.39	0.35	0.33
	50%	0.58	0.66	0.62	0.58
	75%	0.70	0.77	0.74	0.71
	100%	0.78	0.83	0.81	0.79
Bearing type	: <u>Drive end</u> 6205 2RS <u>Non drive end</u> 6204 2RS	Foundation loads			
Sealing	: Oil Seal Lip Seal	Max. traction	: 114 lb		
Lubrication interval	: - -	Max. compression	: 188 lb		
Lubricant amount	: - -				
Lubricant type	: Mobil Polyrex EM				
Notes USABLE @208V 4.53A SF 1.15 SFA 5.21A					
This revision replaces and cancel the previous one, which must be eliminated. (1) Looking the motor from the shaft end. (2) Measured at 1m and with tolerance of +3dB(A). (3) Approximate weight subject to changes after manufacturing process. (4) At 100% of full load.		These are average values based on tests with sinusoidal power supply, subject to the tolerances stipulated in NEMA MG-1.			
Rev.	Changes Summary	Performed	Checked	Date	
Performed by					
Checked by			Page	Revision	
Date	12/04/2022		1 / 22		

DATA SHEET

Three Phase Induction Motor - Squirrel Cage



Customer : _____

Thermal protection

ID	Application	Type	Quantity	Sensing Temperature
1	Winding	Thermostat - 2 wires	1 x Phase	155 °C

Rev.	Changes Summary	Performed	Checked	Date
Performed by				
Checked by			Page	Revision
Date	12/04/2022		2 / 22	

TORQUE AND CURRENT VS SPEED CURVE



Three Phase Induction Motor - Squirrel Cage

Customer :

Product line : NEMA Premium Efficiency Three-Phase

Product code : 14293169

Catalog # : 00158XT3ER145TC

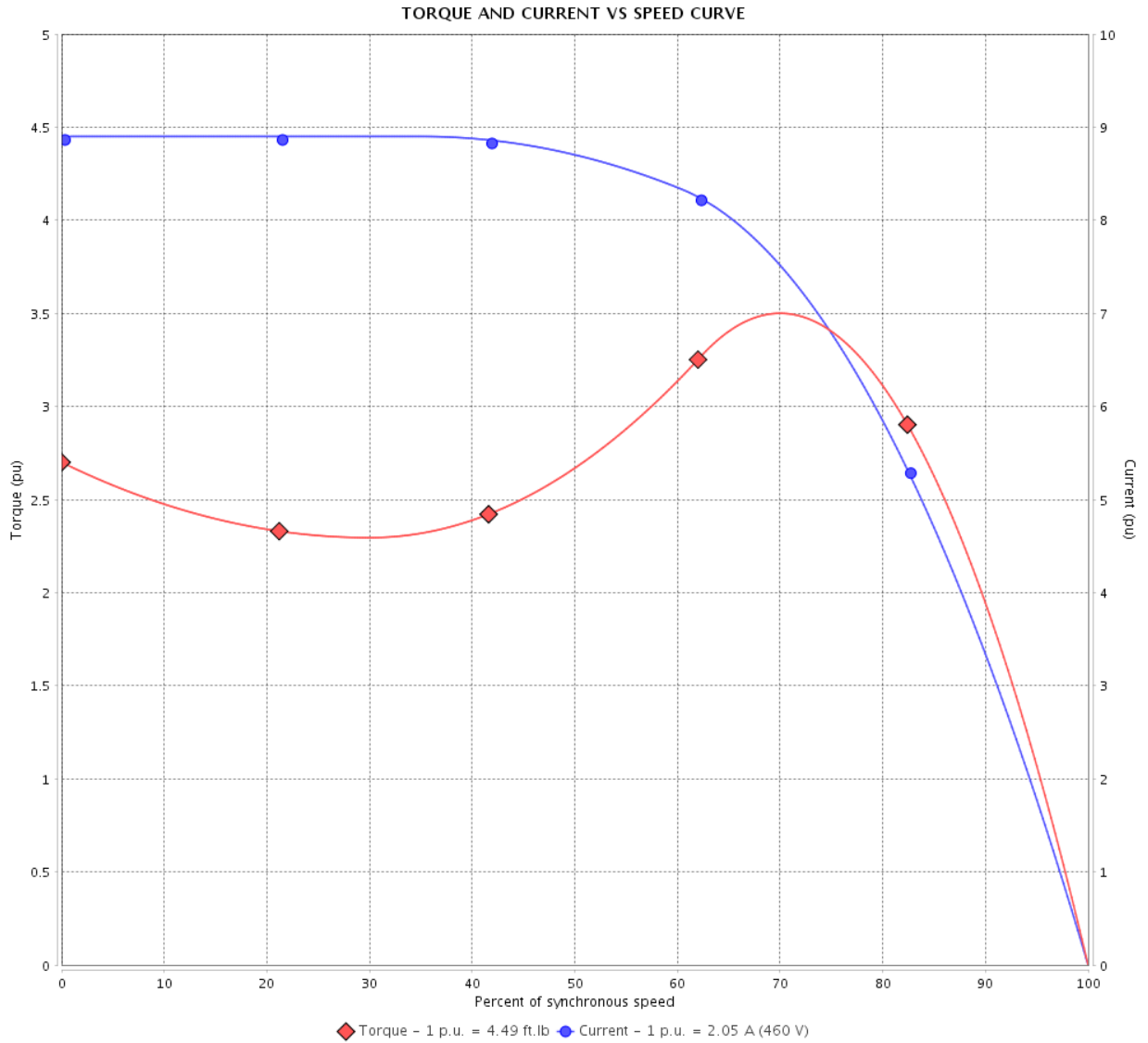

Performance : 230/460 V 60 Hz 4P

Rated current : 4.10/2.05 A
 LRC : 8.9
 Rated torque : 4.49 ft.lb
 Locked rotor torque : 270 %
 Breakdown torque : 350 %
 Rated speed : 1755 rpm

Moment of inertia (J) : 0.1303 sq.ft.lb
 Duty cycle : Cont.(S1)
 Insulation class : F
 Service factor : 1.15
 Temperature rise : 80 K
 Design : B

Locked rotor time : 25s (cold) 14s (hot)

Rev.	Changes Summary	Performed	Checked	Date
Performed by			Page 3 / 22	Revision
Checked by				
Date	12/04/2022			

TORQUE AND CURRENT VS SPEED CURVE

Three Phase Induction Motor - Squirrel Cage



Customer :

Product line : NEMA Premium Efficiency Three-Phase

Product code : 14293169

Catalog # : 00158XT3ER145TC

TORQUE AND CURRENT VS SPEED CURVE

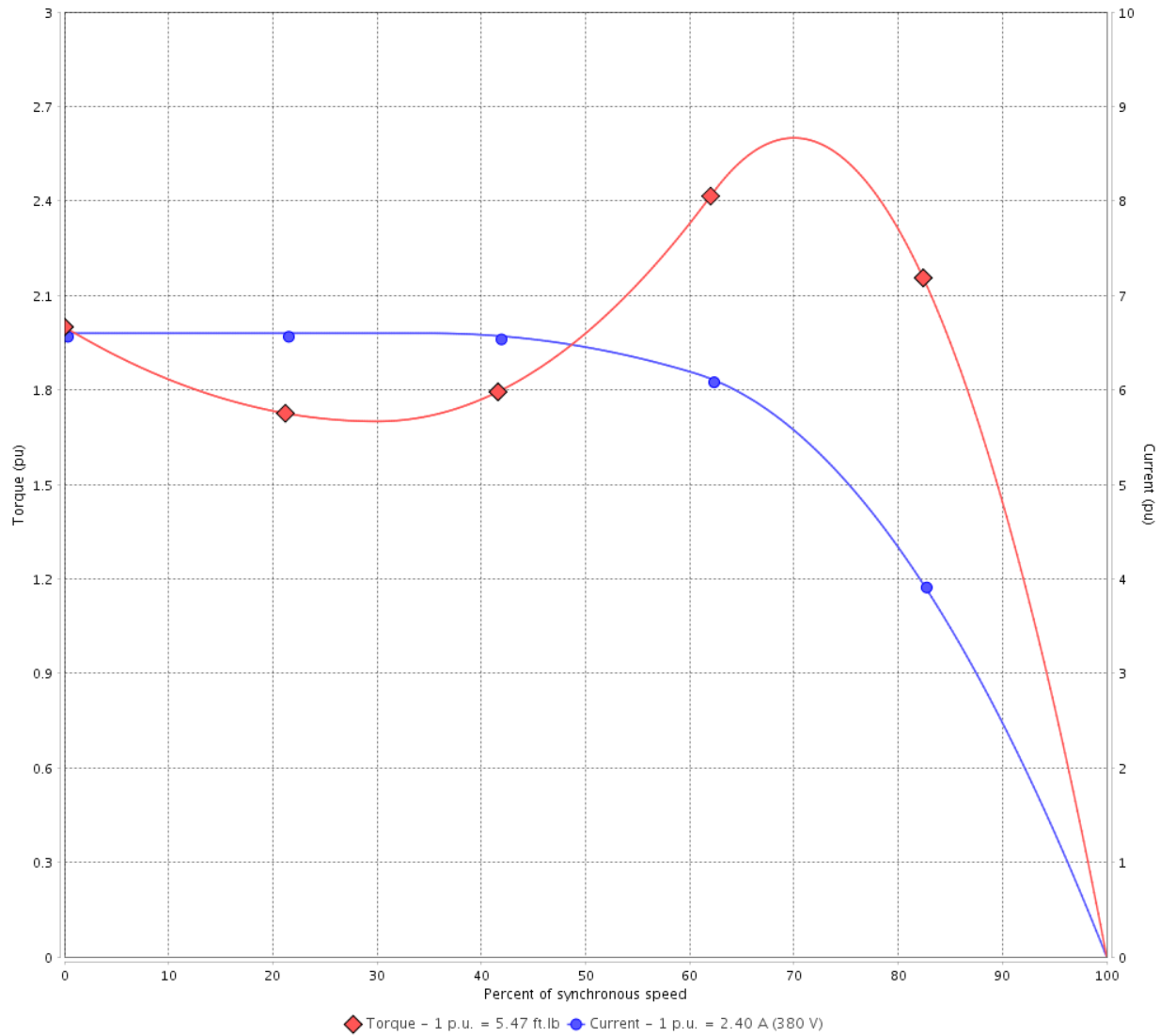

Performance : 380 V 50 Hz 4P IE2

Rated current	: 2.40 A	Moment of inertia (J)	: 0.1303 sq.ft.lb
LRC	: 6.6	Duty cycle	: Cont.(S1)
Rated torque	: 5.47 ft.lb	Insulation class	: F
Locked rotor torque	: 200 %	Service factor	: 1.00
Breakdown torque	: 260 %	Temperature rise	: 80 K
Rated speed	: 1440 rpm	Design	: B

Locked rotor time : 27s (cold) 15s (hot)

Rev.	Changes Summary	Performed	Checked	Date
Performed by			Page 4 / 22	Revision
Checked by				
Date	12/04/2022			

TORQUE AND CURRENT VS SPEED CURVE



Three Phase Induction Motor - Squirrel Cage

Customer :

Product line : NEMA Premium Efficiency Three-Phase

Product code : 14293169

Catalog # : 00158XT3ER145TC

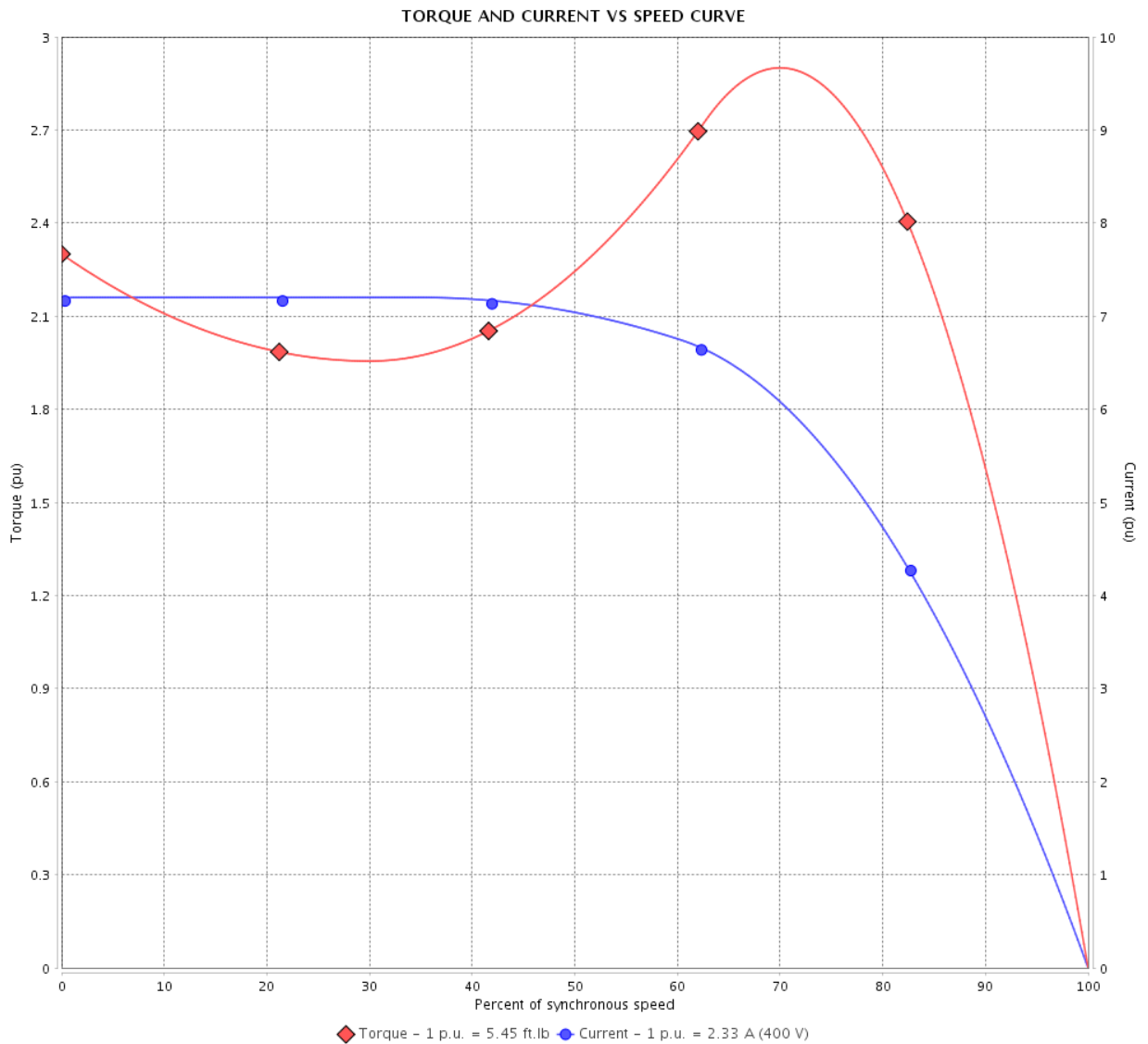

Performance : 400 V 50 Hz 4P IE2

Rated current	: 2.33 A	Moment of inertia (J)	: 0.1303 sq.ft.lb
LRC	: 7.2	Duty cycle	: Cont.(S1)
Rated torque	: 5.45 ft.lb	Insulation class	: F
Locked rotor torque	: 229 %	Service factor	: 1.00
Breakdown torque	: 290 %	Temperature rise	: 80 K
Rated speed	: 1445 rpm	Design	: B

Locked rotor time : 27s (cold) 15s (hot)

Rev.	Changes Summary	Performed	Checked	Date
Performed by			Page	Revision
Checked by			5 / 22	
Date	12/04/2022			

TORQUE AND CURRENT VS SPEED CURVE

Three Phase Induction Motor - Squirrel Cage



Customer :

Product line : NEMA Premium Efficiency Three-Phase

Product code : 14293169

Catalog # : 00158XT3ER145TC

TORQUE AND CURRENT VS SPEED CURVE

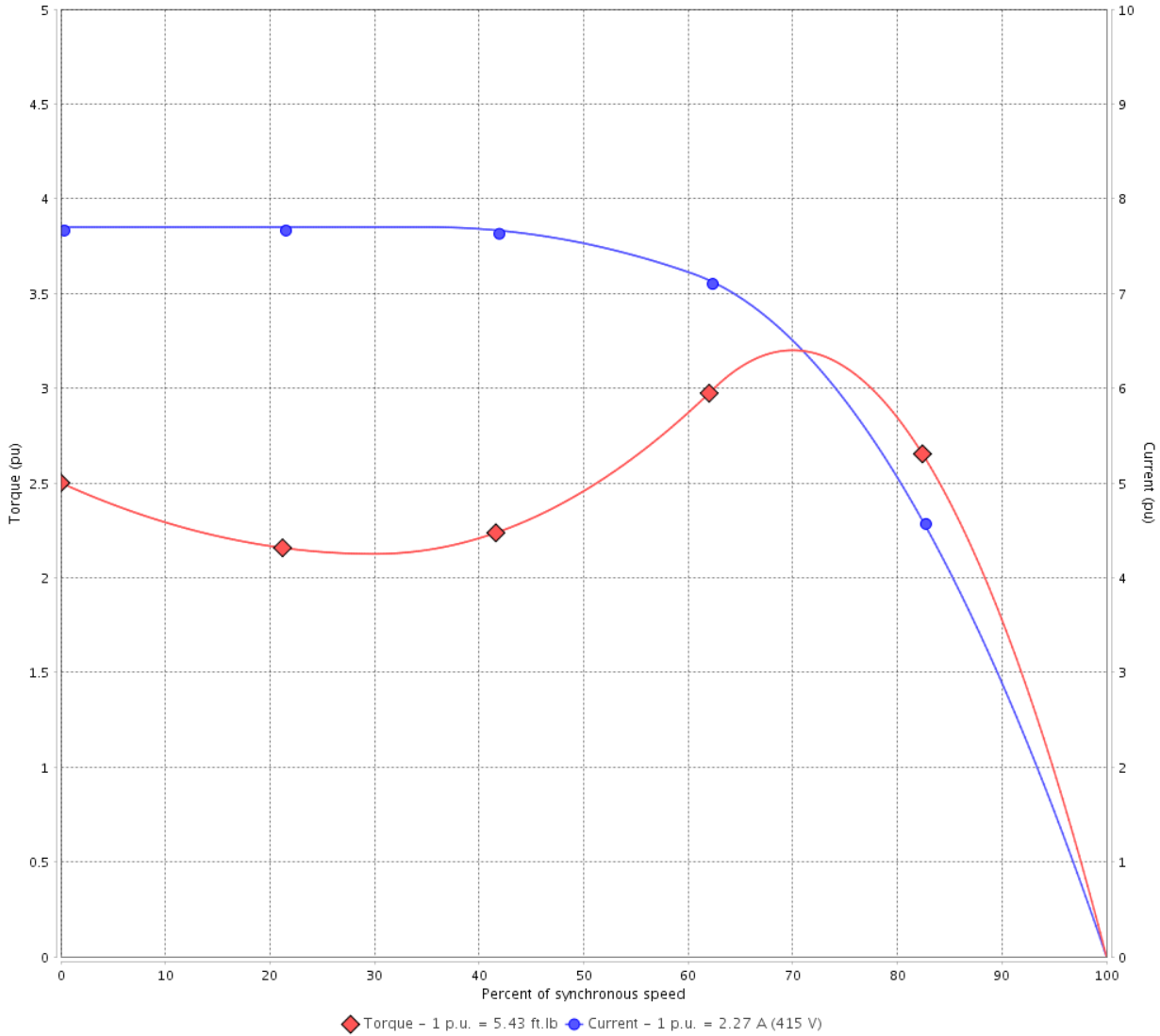

Performance : 415 V 50 Hz 4P IE3

Rated current	: 2.27 A	Moment of inertia (J)	: 0.1303 sq.ft.lb
LRC	: 7.7	Duty cycle	: Cont.(S1)
Rated torque	: 5.43 ft.lb	Insulation class	: F
Locked rotor torque	: 250 %	Service factor	: 1.00
Breakdown torque	: 320 %	Temperature rise	: 80 K
Rated speed	: 1450 rpm	Design	: B

Locked rotor time : 27s (cold) 15s (hot)

Rev.	Changes Summary	Performed	Checked	Date
Performed by			Page 6 / 22	Revision
Checked by				
Date	12/04/2022			

LOAD PERFORMANCE CURVE

Three Phase Induction Motor - Squirrel Cage



Customer :

Product line : NEMA Premium Efficiency Three-Phase

Product code : 14293169

Catalog # : 00158XT3ER145TC

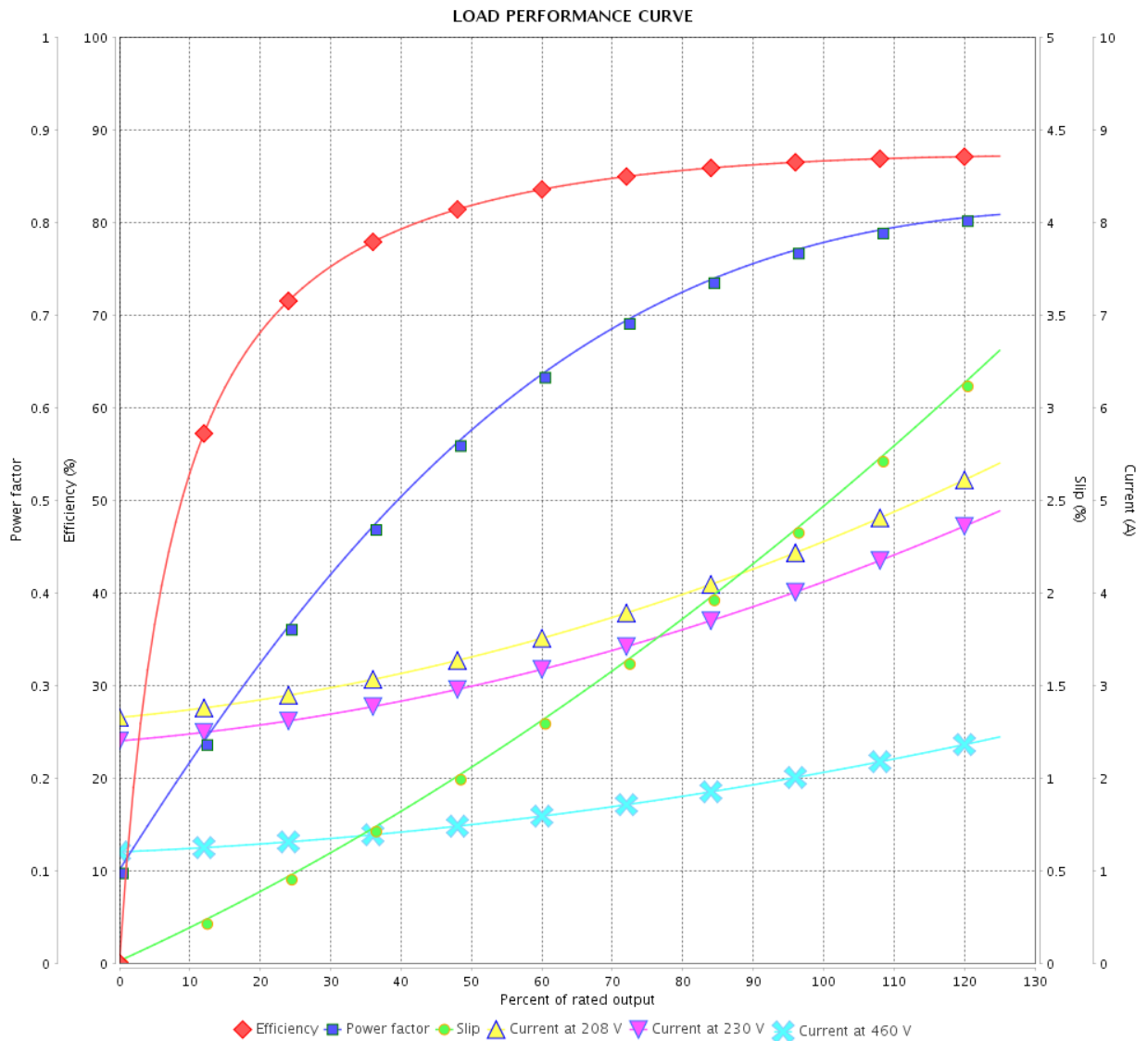

Performance : 230/460 V 60 Hz 4P

Rated current : 4.10/2.05 A
 LRC : 8.9
 Rated torque : 4.49 ft.lb
 Locked rotor torque : 270 %
 Breakdown torque : 350 %
 Rated speed : 1755 rpm

Moment of inertia (J) : 0.1303 sq.ft.lb
 Duty cycle : Cont.(S1)
 Insulation class : F
 Service factor : 1.15
 Temperature rise : 80 K
 Design : B

Rev.	Changes Summary	Performed	Checked	Date
Performed by			Page	Revision
Checked by				
Date				

LOAD PERFORMANCE CURVE

Three Phase Induction Motor - Squirrel Cage



Customer :

Product line : NEMA Premium Efficiency Three-Phase

Product code : 14293169

Catalog # : 00158XT3ER145TC

LOAD PERFORMANCE CURVE

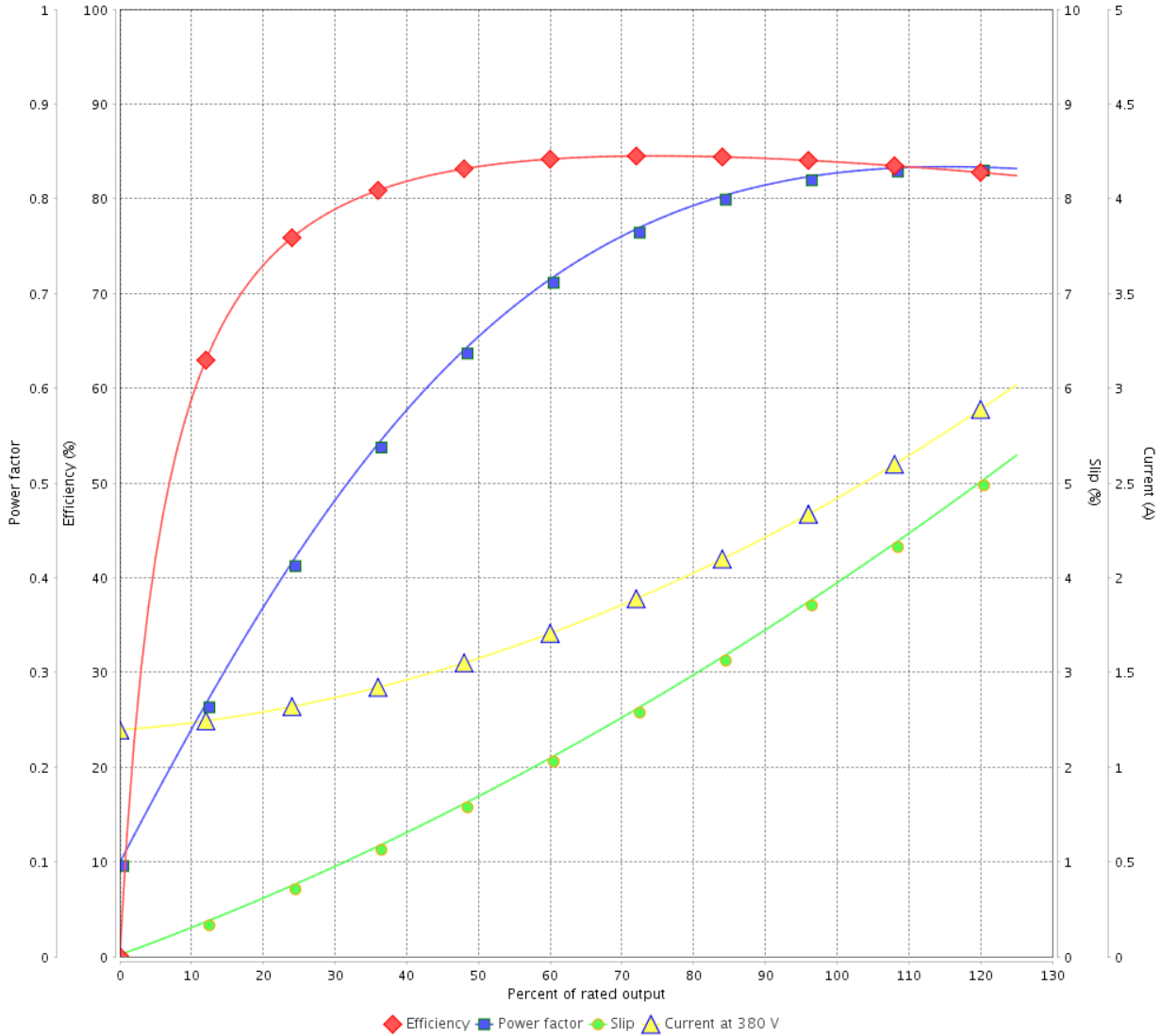

Performance : 380 V 50 Hz 4P IE2

Rated current : 2.40 A
 LRC : 6.6
 Rated torque : 5.47 ft.lb
 Locked rotor torque : 200 %
 Breakdown torque : 260 %
 Rated speed : 1440 rpm

Moment of inertia (J) : 0.1303 sq.ft.lb
 Duty cycle : Cont.(S1)
 Insulation class : F
 Service factor : 1.00
 Temperature rise : 80 K
 Design : B

Rev.	Changes Summary	Performed	Checked	Date
Performed by			Page	Revision
Checked by			8 / 22	
Date	12/04/2022			

LOAD PERFORMANCE CURVE

Three Phase Induction Motor - Squirrel Cage



Customer : _____

Product line : NEMA Premium Efficiency Three-Phase

Product code : 14293169

Catalog # : 00158XT3ER145TC

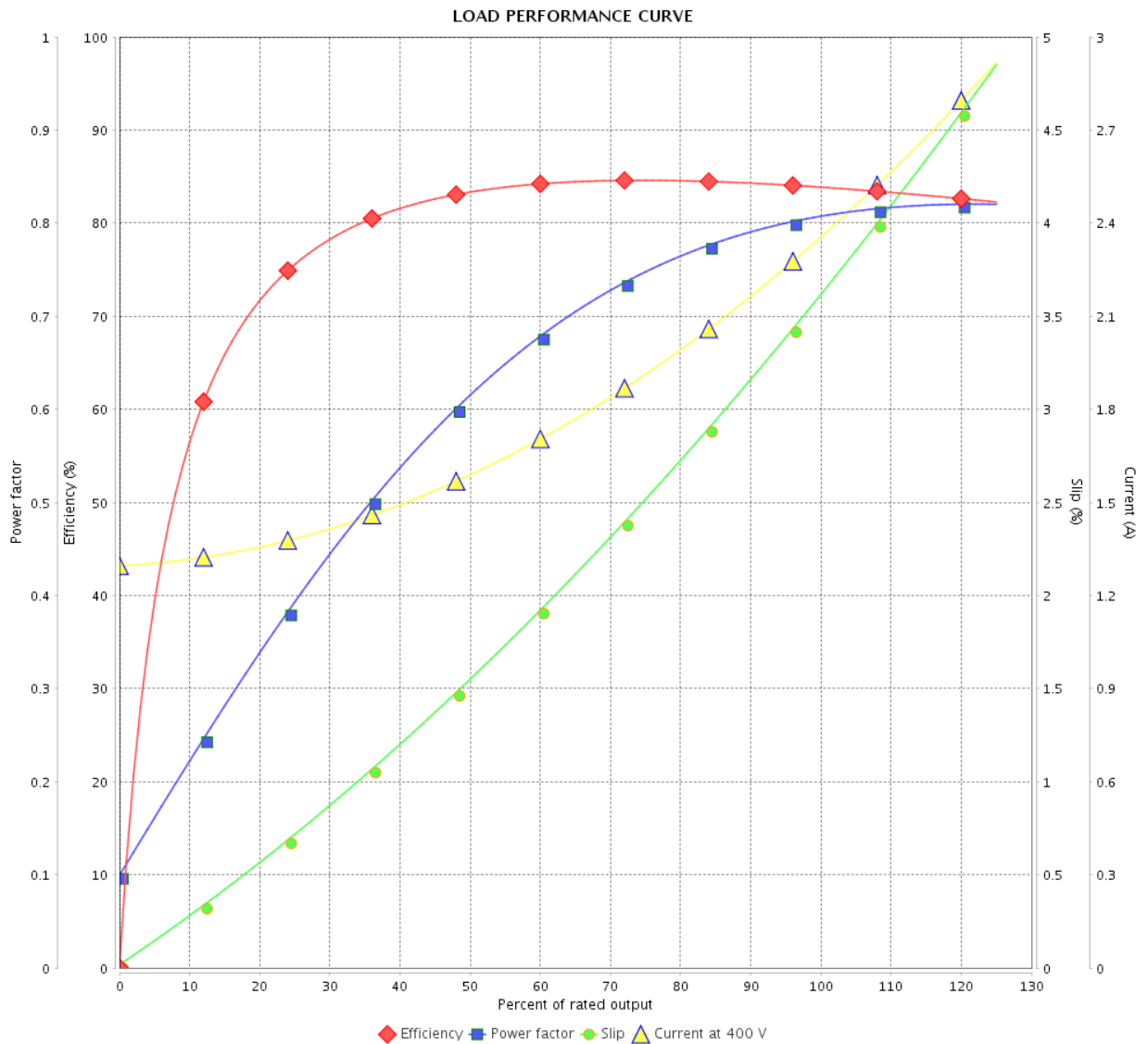

Performance : 400 V 50 Hz 4P IE2

Rated current : 2.33 A
 LRC : 7.2
 Rated torque : 5.45 ft.lb
 Locked rotor torque : 229 %
 Breakdown torque : 290 %
 Rated speed : 1445 rpm

Moment of inertia (J) : 0.1303 sq.ft.lb
 Duty cycle : Cont.(S1)
 Insulation class : F
 Service factor : 1.00
 Temperature rise : 80 K
 Design : B

Rev.	Changes Summary	Performed	Checked	Date
Performed by		Page		Revision
Checked by		9 / 22		
Date		12/04/2022		

LOAD PERFORMANCE CURVE

Three Phase Induction Motor - Squirrel Cage



Customer :

Product line : NEMA Premium Efficiency Three-Phase

Product code : 14293169

Catalog # : 00158XT3ER145TC

LOAD PERFORMANCE CURVE

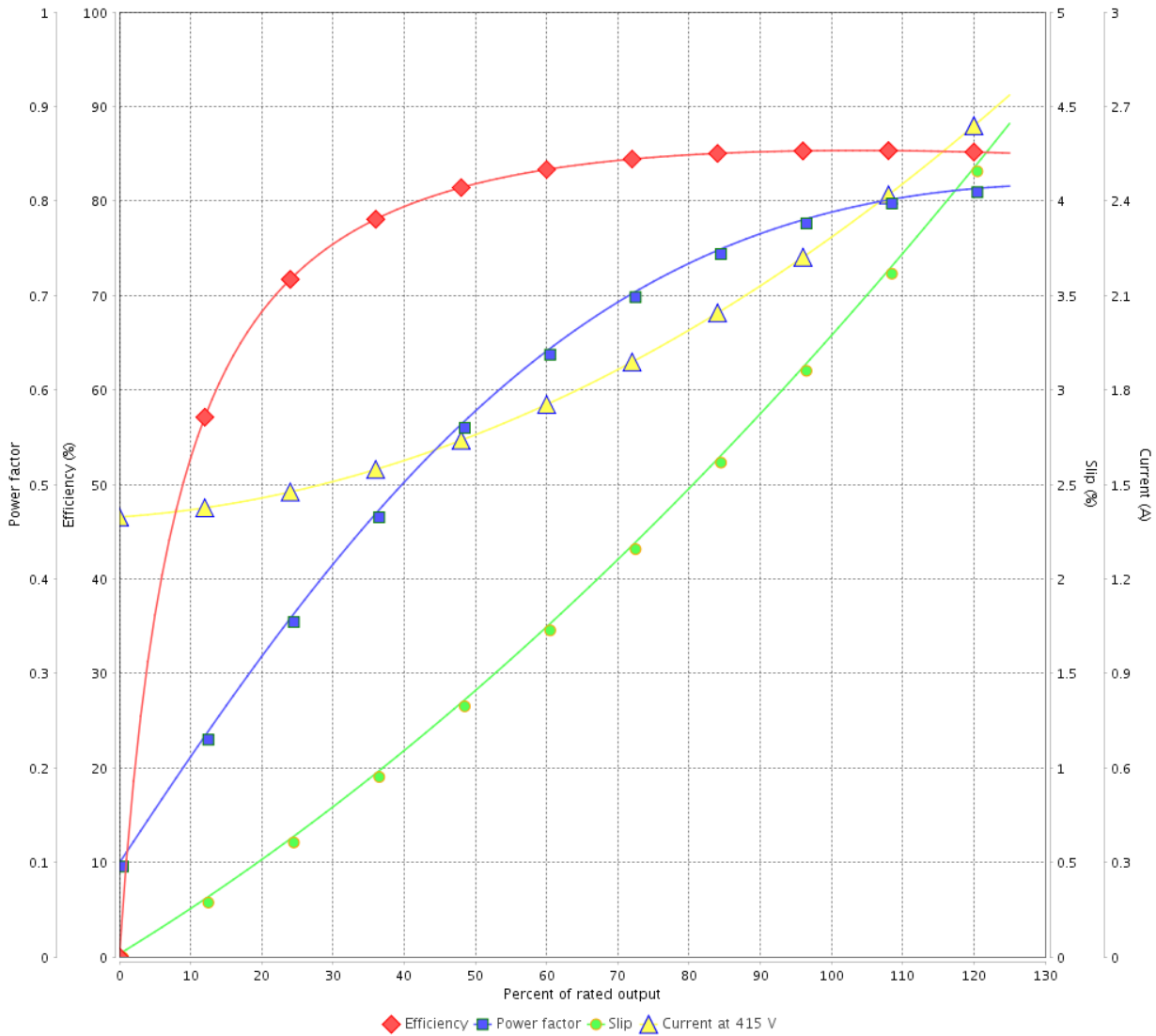

Performance : 415 V 50 Hz 4P IE3

Rated current : 2.27 A
 LRC : 7.7
 Rated torque : 5.43 ft.lb
 Locked rotor torque : 250 %
 Breakdown torque : 320 %
 Rated speed : 1450 rpm

Moment of inertia (J) : 0.1303 sq.ft.lb
 Duty cycle : Cont.(S1)
 Insulation class : F
 Service factor : 1.00
 Temperature rise : 80 K
 Design : B

Rev.	Changes Summary	Performed	Checked	Date
Performed by			Page	Revision
Checked by			10 / 22	
Date	12/04/2022			

THERMAL LIMIT CURVE



Three Phase Induction Motor - Squirrel Cage

Customer :

Product line : NEMA Premium Efficiency Three-Phase
 Product code : 14293169
 Catalog # : 00158XT3ER145TC

Performance : 230/460 V 60 Hz 4P

Rated current : 4.10/2.05 A	Moment of inertia (J) : 0.1303 sq.ft.lb
LRC : 8.9	Duty cycle : Cont.(S1)
Rated torque : 4.49 ft.lb	Insulation class : F
Locked rotor torque : 270 %	Service factor : 1.15
Breakdown torque : 350 %	Temperature rise : 80 K
Rated speed : 1755 rpm	Design : B

Heating constant

Cooling constant

Rev.	Changes Summary	Performed	Checked	Date
Performed by			Page 11 / 22	Revision
Checked by				
Date	12/04/2022			

THERMAL LIMIT CURVE

Three Phase Induction Motor - Squirrel Cage

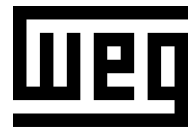

Customer : _____

THERMAL LIMIT CURVE

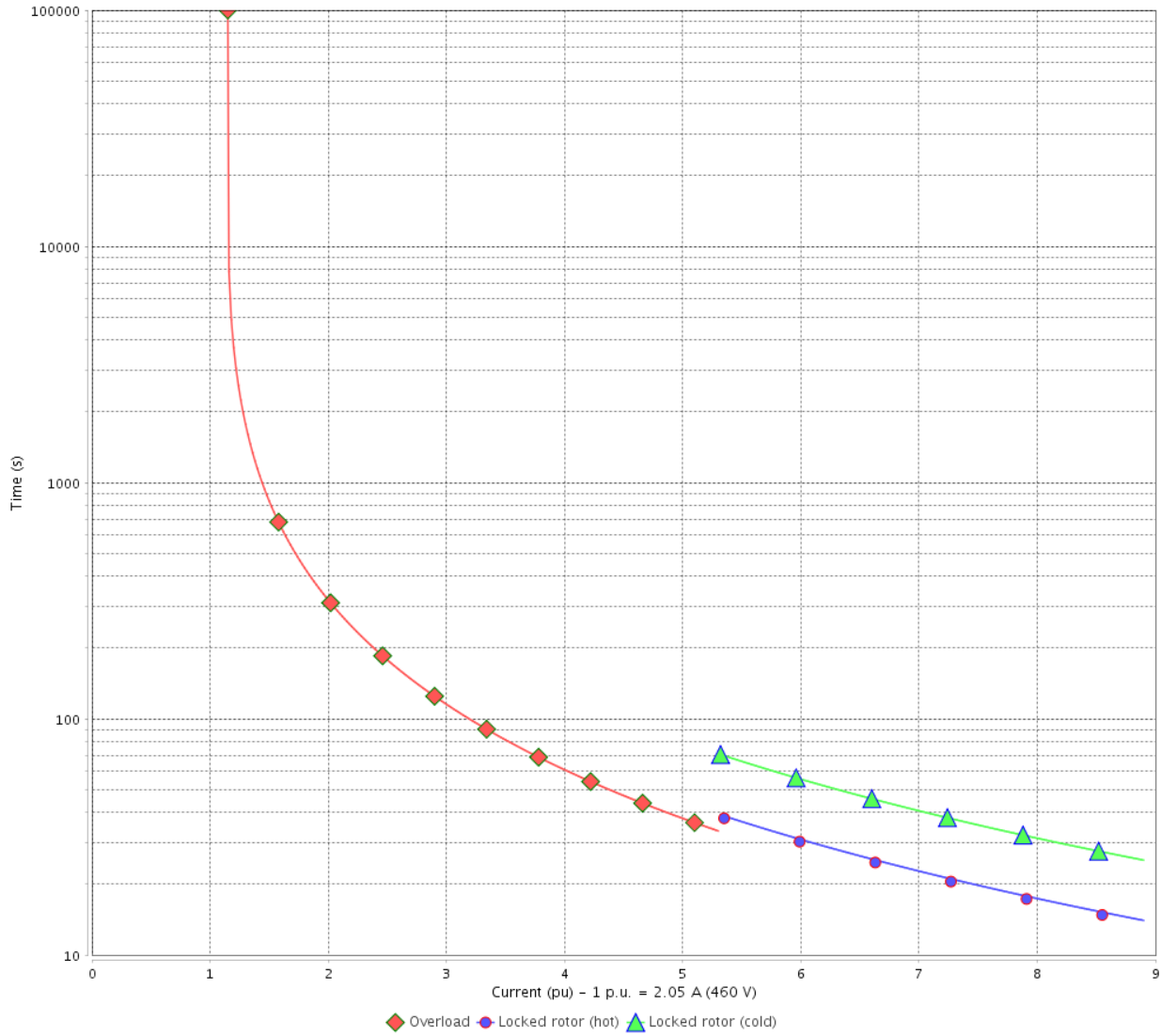

Rev.	Changes Summary	Performed	Checked	Date
Performed by			Page 12 / 22	Revision
Checked by				
Date	12/04/2022			

THERMAL LIMIT CURVE



Three Phase Induction Motor - Squirrel Cage

Customer :

Product line : NEMA Premium Efficiency Three-Phase
 Product code : 14293169
 Catalog # : 00158XT3ER145TC

Performance : 380 V 50 Hz 4P IE2

Rated current : 2.40 A	Moment of inertia (J) : 0.1303 sq.ft.lb
LRC : 6.6	Duty cycle : Cont.(S1)
Rated torque : 5.47 ft.lb	Insulation class : F
Locked rotor torque : 200 %	Service factor : 1.00
Breakdown torque : 260 %	Temperature rise : 80 K
Rated speed : 1440 rpm	Design : B

Heating constant

Cooling constant

Rev.	Changes Summary	Performed	Checked	Date
Performed by			Page 13 / 22	Revision
Checked by				
Date	12/04/2022			

THERMAL LIMIT CURVE

Three Phase Induction Motor - Squirrel Cage



Customer : _____

THERMAL LIMIT CURVE

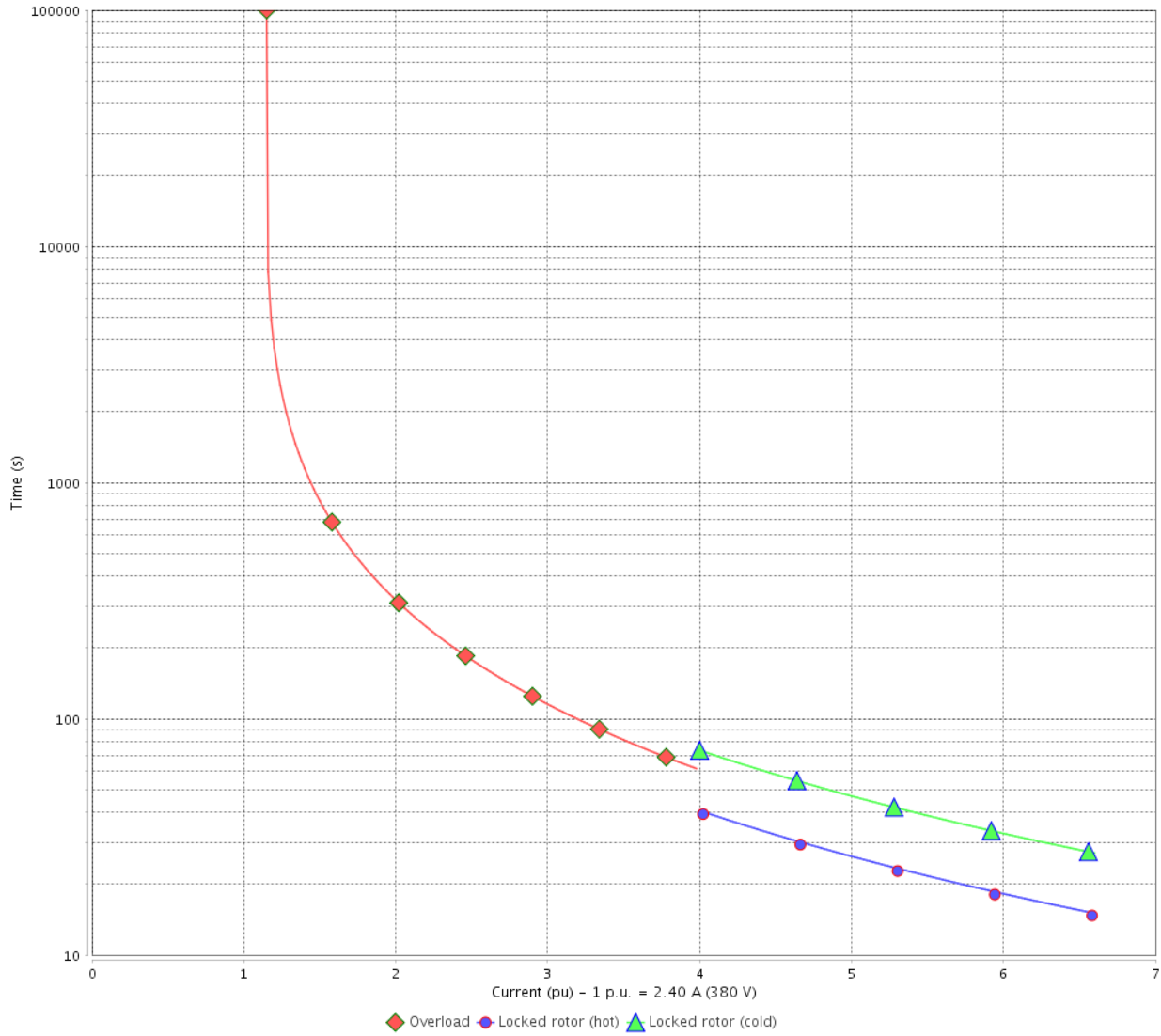

Rev.	Changes Summary	Performed	Checked	Date
Performed by		Page		Revision
Checked by		14 / 22		
Date		12/04/2022		

THERMAL LIMIT CURVE



Three Phase Induction Motor - Squirrel Cage

Customer :

Product line : NEMA Premium Efficiency Three-Phase
 Product code : 14293169
 Catalog # : 00158XT3ER145TC

Performance : 400 V 50 Hz 4P IE2

Rated current : 2.33 A	Moment of inertia (J) : 0.1303 sq.ft.lb
LRC : 7.2	Duty cycle : Cont.(S1)
Rated torque : 5.45 ft.lb	Insulation class : F
Locked rotor torque : 229 %	Service factor : 1.00
Breakdown torque : 290 %	Temperature rise : 80 K
Rated speed : 1445 rpm	Design : B

Heating constant

Cooling constant

Rev.	Changes Summary	Performed	Checked	Date
Performed by			Page 15 / 22	Revision
Checked by				
Date	12/04/2022			

THERMAL LIMIT CURVE

Three Phase Induction Motor - Squirrel Cage



Customer : _____

THERMAL LIMIT CURVE

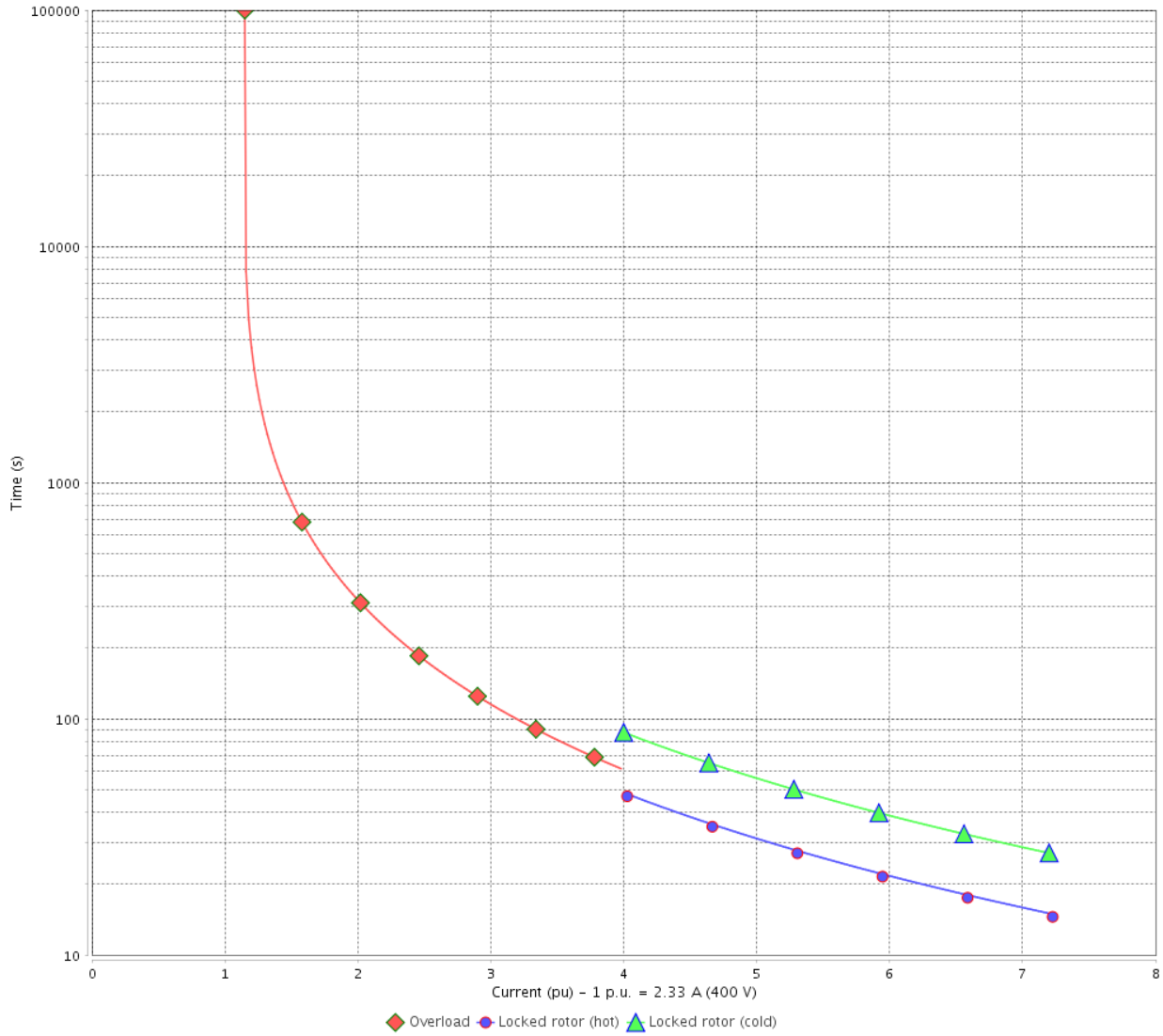

Rev.	Changes Summary	Performed	Checked	Date
Performed by		Page		Revision
Checked by		16 / 22		
Date		12/04/2022		

THERMAL LIMIT CURVE



Three Phase Induction Motor - Squirrel Cage

Customer :

Product line : NEMA Premium Efficiency Three-Phase
 Product code : 14293169
 Catalog # : 00158XT3ER145TC

Performance : 415 V 50 Hz 4P IE3

Rated current : 2.27 A	Moment of inertia (J) : 0.1303 sq.ft.lb
LRC : 7.7	Duty cycle : Cont.(S1)
Rated torque : 5.43 ft.lb	Insulation class : F
Locked rotor torque : 250 %	Service factor : 1.00
Breakdown torque : 320 %	Temperature rise : 80 K
Rated speed : 1450 rpm	Design : B

Heating constant

Cooling constant

Rev.	Changes Summary	Performed	Checked	Date
Performed by			Page 17 / 22	Revision
Checked by				
Date	12/04/2022			

THERMAL LIMIT CURVE

Three Phase Induction Motor - Squirrel Cage



Customer : _____

THERMAL LIMIT CURVE

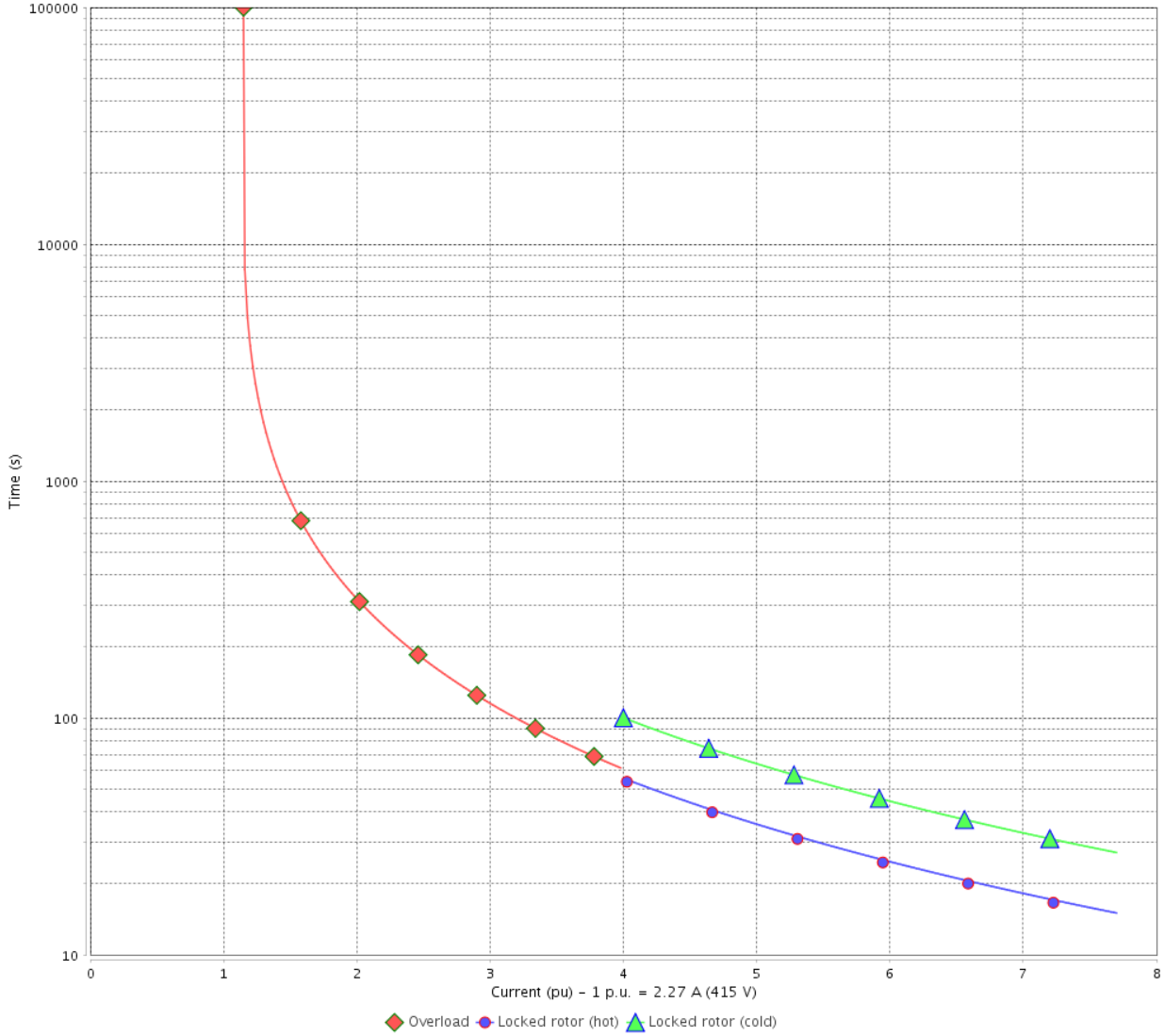

Rev.	Changes Summary	Performed	Checked	Date
Performed by		Page		Revision
Checked by		18 / 22		
Date		12/04/2022		

VFD OPERATION CURVE

Three Phase Induction Motor - Squirrel Cage



Customer :

Product line : NEMA Premium Efficiency Three-Phase

Product code : 14293169

Catalog # : 00158XT3ER145TC

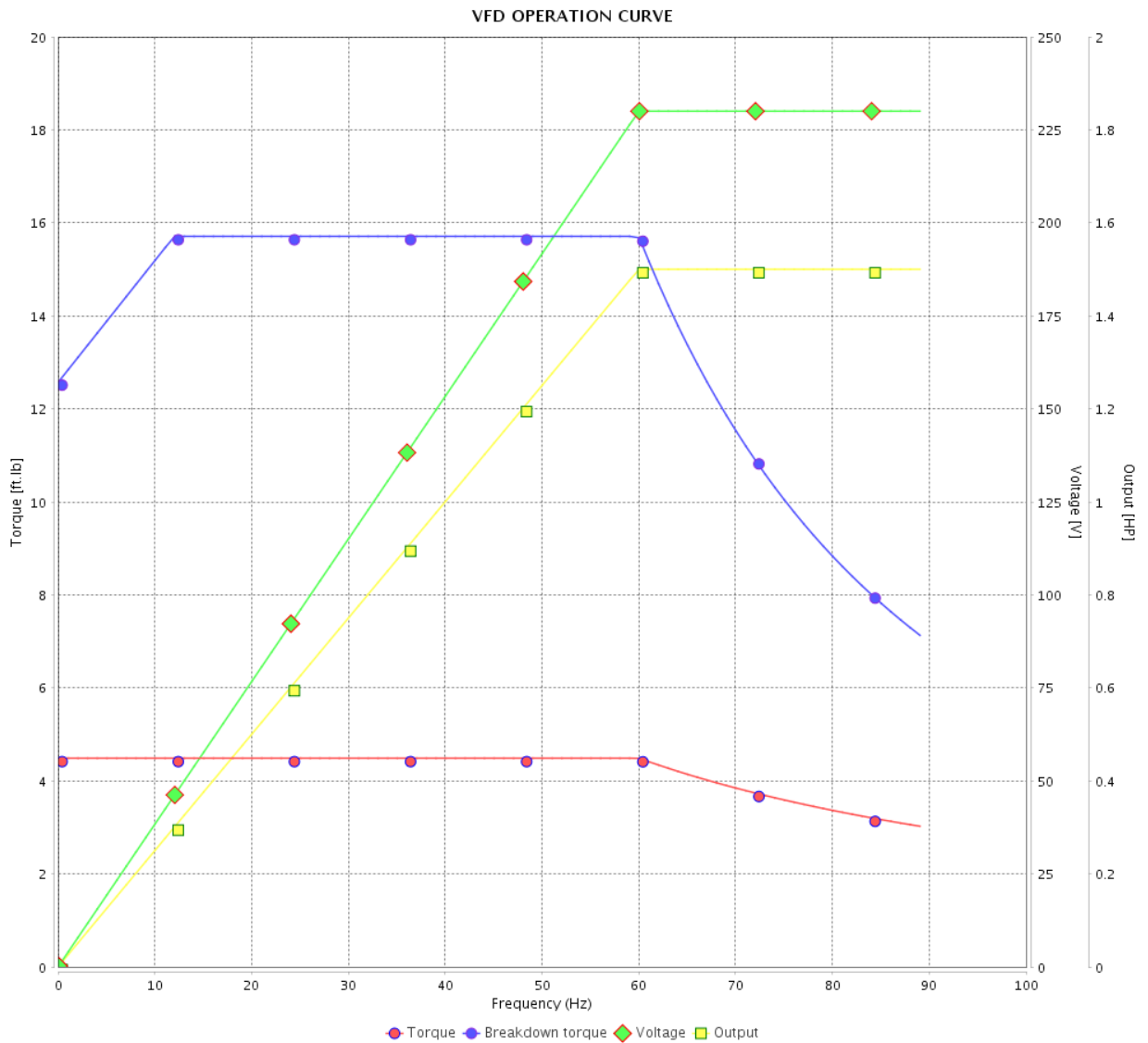

Performance : 230/460 V 60 Hz 4P

Rated current : 4.10/2.05 A
 LRC : 8.9
 Rated torque : 4.49 ft.lb
 Locked rotor torque : 270 %
 Breakdown torque : 350 %
 Rated speed : 1755 rpm

Moment of inertia (J) : 0.1303 sq.ft.lb
 Duty cycle : Cont.(S1)
 Insulation class : F
 Service factor : 1.15
 Temperature rise : 80 K
 Design : B

Rev.	Changes Summary	Performed	Checked	Date
Performed by				Page 19 / 22
Checked by				
Date	12/04/2022			

VFD OPERATION CURVE

Three Phase Induction Motor - Squirrel Cage



Customer : _____

Product line : NEMA Premium Efficiency Three-Phase

Product code : 14293169

Catalog # : 00158XT3ER145TC

VFD OPERATION CURVE

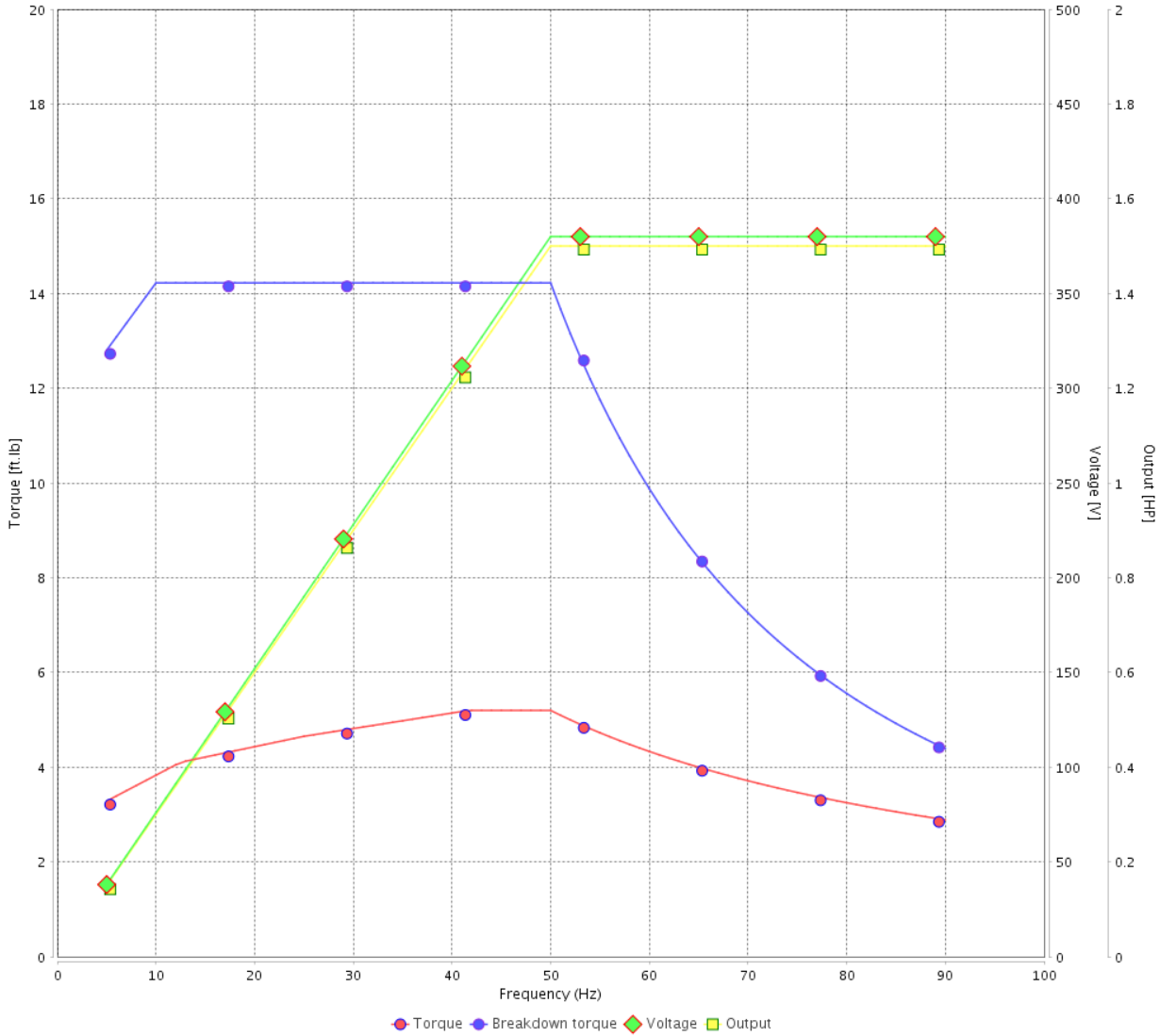

Performance : 380 V 50 Hz 4P IE2

Rated current : 2.40 A
 LRC : 6.6
 Rated torque : 5.47 ft.lb
 Locked rotor torque : 200 %
 Breakdown torque : 260 %
 Rated speed : 1440 rpm

Moment of inertia (J) : 0.1303 sq.ft.lb
 Duty cycle : Cont.(S1)
 Insulation class : F
 Service factor : 1.00
 Temperature rise : 80 K
 Design : B

Rev.	Changes Summary	Performed	Checked	Date
Performed by			Page 20 / 22	Revision
Checked by				
Date	12/04/2022			

VFD OPERATION CURVE

Three Phase Induction Motor - Squirrel Cage



Customer :

Product line : NEMA Premium Efficiency Three-Phase

Product code : 14293169

Catalog # : 00158XT3ER145TC

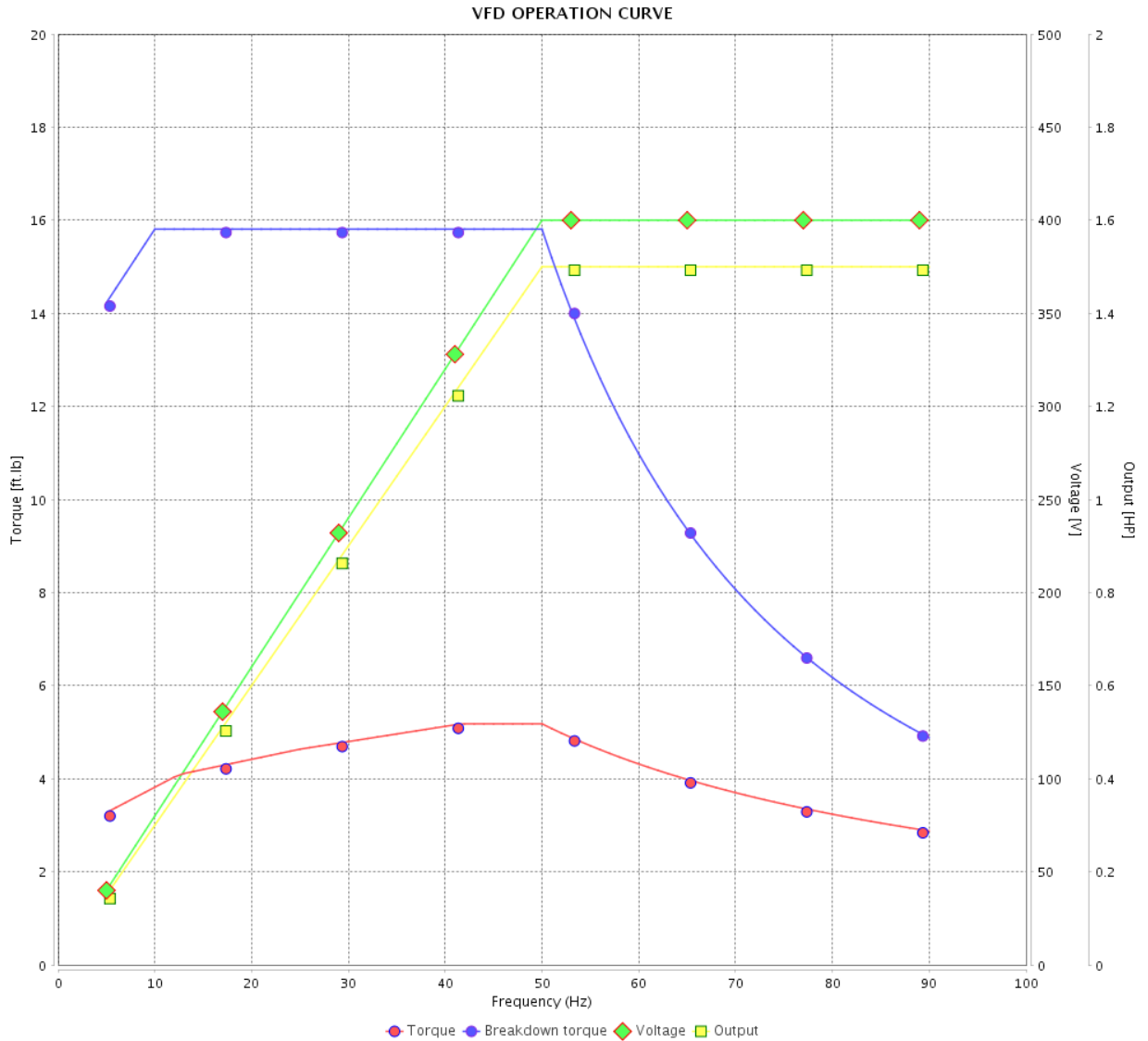

Performance : 400 V 50 Hz 4P IE2

Rated current : 2.33 A
 LRC : 7.2
 Rated torque : 5.45 ft.lb
 Locked rotor torque : 229 %
 Breakdown torque : 290 %
 Rated speed : 1445 rpm

Moment of inertia (J) : 0.1303 sq.ft.lb
 Duty cycle : Cont.(S1)
 Insulation class : F
 Service factor : 1.00
 Temperature rise : 80 K
 Design : B

Rev.	Changes Summary	Performed	Checked	Date
Performed by			Page	Revision
Checked by			21 / 22	
Date	12/04/2022			

VFD OPERATION CURVE

Three Phase Induction Motor - Squirrel Cage



Customer : _____

Product line : NEMA Premium Efficiency Three-Phase

Product code : 14293169

Catalog # : 00158XT3ER145TC

VFD OPERATION CURVE

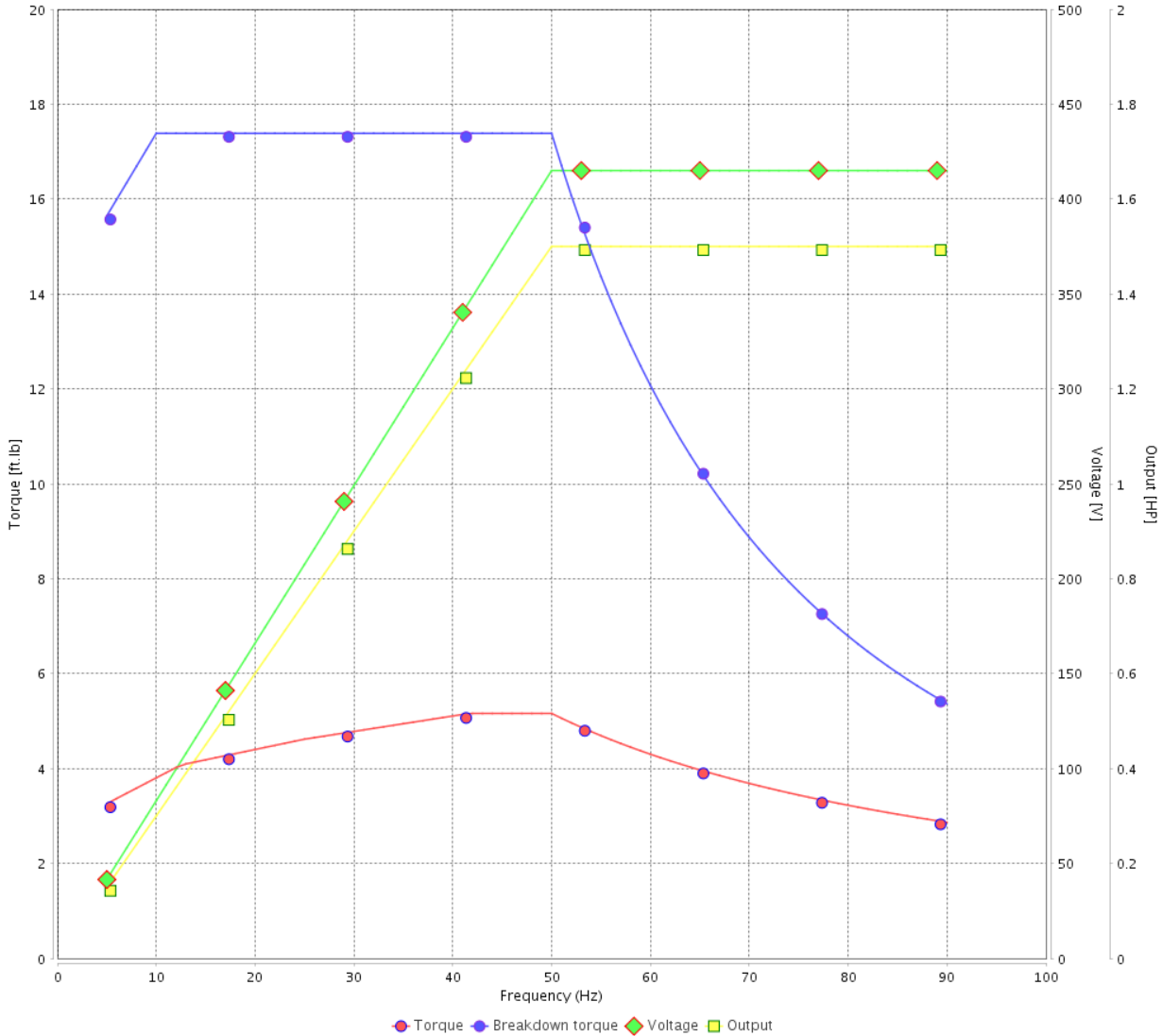

Performance : 415 V 50 Hz 4P IE3

Rated current : 2.27 A
 LRC : 7.7
 Rated torque : 5.43 ft.lb
 Locked rotor torque : 250 %
 Breakdown torque : 320 %
 Rated speed : 1450 rpm

Moment of inertia (J) : 0.1303 sq.ft.lb
 Duty cycle : Cont.(S1)
 Insulation class : F
 Service factor : 1.00
 Temperature rise : 80 K
 Design : B

Rev.	Changes Summary	Performed	Checked	Date
Performed by			Page 22 / 22	Revision
Checked by				
Date	12/04/2022			

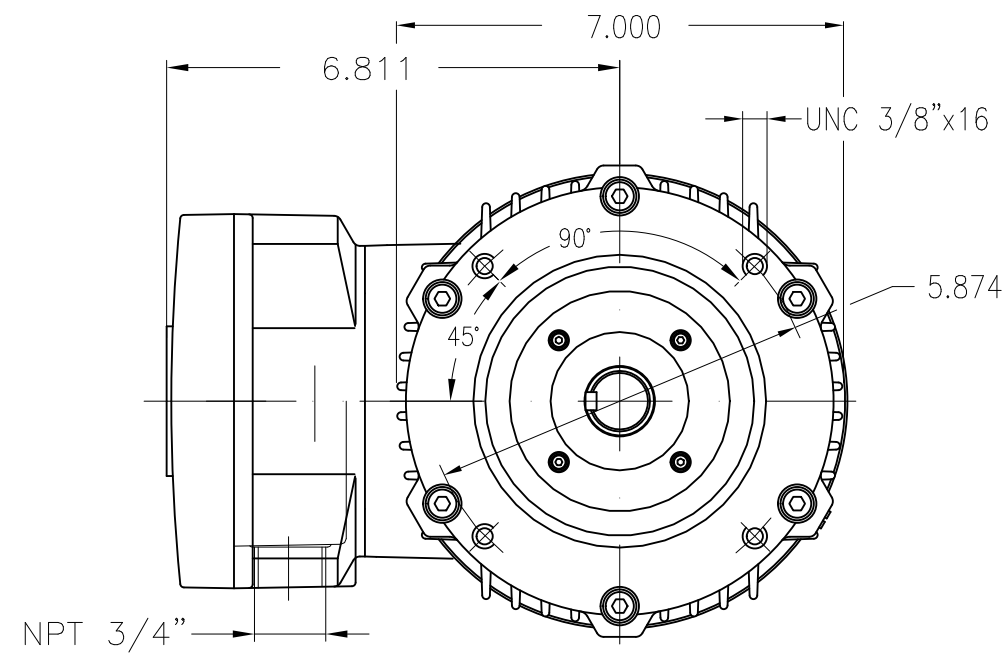

Grounding for leads 0.5–6 mm² / 20–10 AWG

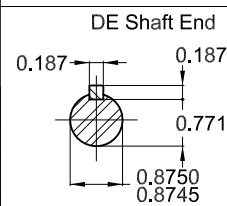
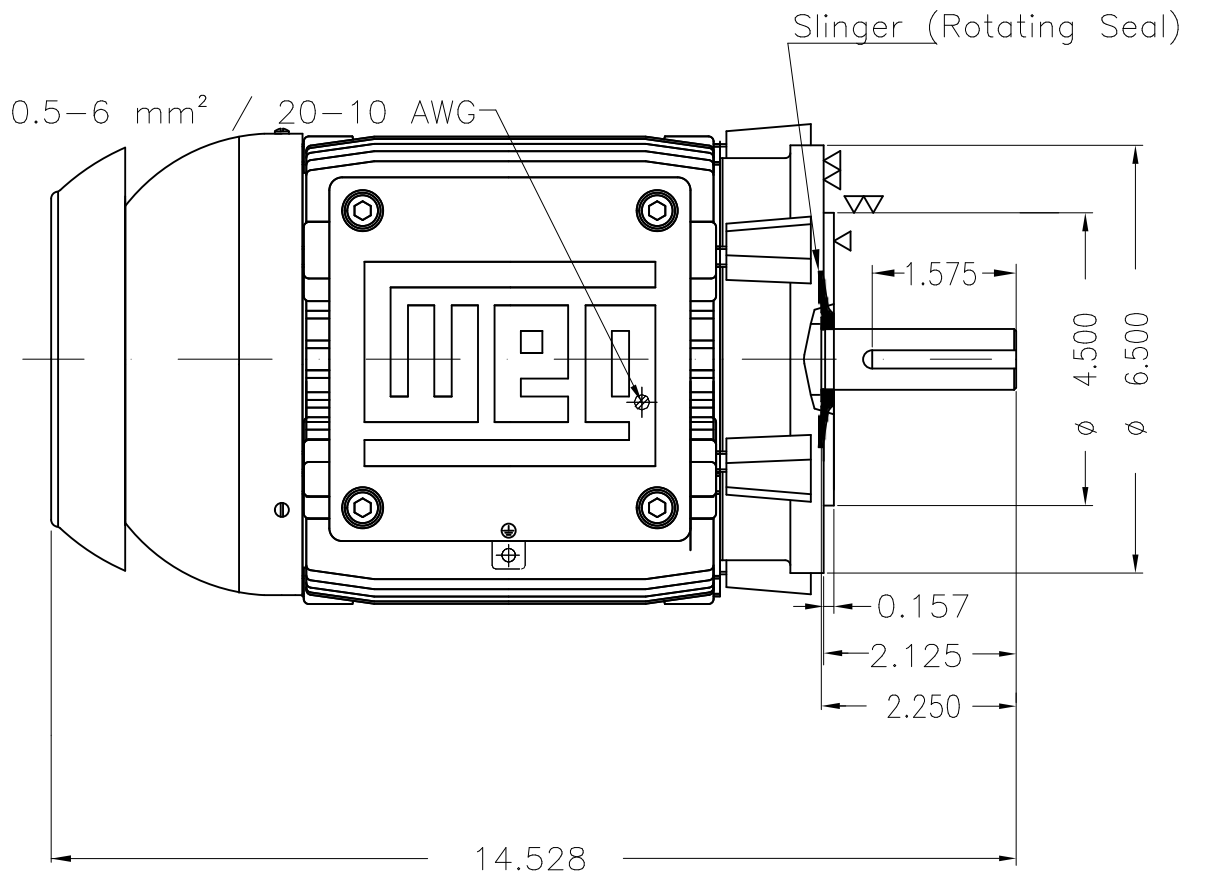

Color RAL 5009
 Painting plan 202P
 Mounting NEMA W-6
 Mounting V18

1.5 HP 04 Poles 60 Hz

Dimensions in inches

ECM	LOC	SUMMARY OF MODIFICATIONS	EXECUTED	CHECKED	RELEASED	DATE	VER
EXECUTED	PIRWBUSER	THREE PH. MOTOR EXPLOSION PROOF PREM. EFF.					
CHECKED		FRAME 143/5TC IP55 TEFC					
RELEASED							
REL DT.	WMO	Jaragua do Sul	Product Engineering				

PREVIEW
 WDD



SHEET 1 / 1

MADE IN BRAZIL

**W21X NEMA**
Premium

14293169

CC029A

Inverter Duty Motor
Severe Duty

MODEL 00158XT3ER145TC

PH 3	FR 143/5TC		
HP(kW) 1.5(1.1)		HZ 60	IP55
V 230/460		A 4.10/2.05	
RPM 1755		NEMA NOM EFF 86.5%	
PF 0.78		SFA 4.71/2.36	DES B
INS CL F Δ T 80 K		SF 1.15	ENCL TEFC
DUTY CONT.		CODE L	ALT 1000 m.a.s.l.
AMB 40°C	USABLE @208V	4.53 A	SF 1.15 SFA 5.21
AMB 55°C SF1.0			

1.5HP 1.1kW 50Hz 380V 2.40A 1440RPM SF1.00 EFF 84.0% (IE2)

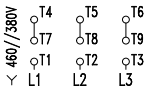
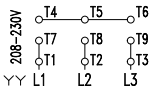

→ 6205-2RS MOBIL POLYREX EM
→ 6204-2RS

75 Lbs



TEMP CODE T3C
CSA/UL: Class I - Div. 1 - Groups C and D
CSA: Class II - Div. 1 - Groups F and G
CSA: Class I - Zone 1 - IIB

EXPLOSION PROOF MOTOR

FOR USE ON VPWM VFD 1000:1VT, 20:1CT, 1.0SF, T3C, AMB 40°C.