

DATA SHEET

Three Phase Induction Motor - Squirrel Cage



Customer :				
Product line	: NEMA Premium Efficiency Three-Phase	Product code :	12674940	
		Catalog # :	00336OT3E145T-SG	
Frame	: 143/5T	Cooling method	: IC01 - ODP	
Insulation class	: F	Mounting	: F-1	
Duty cycle	: Cont.(S1)	Rotation ¹	: Both (CW and CCW)	
Ambient temperature	: -20°C to +40°C	Starting method	: Direct On Line	
Altitude	: 1000 m.a.s.l.	Approx. weight ²	: 40.6 lb	
Design	: B	Moment of inertia (J)	: 0.1279 sq.ft.lb	
Output [HP]	3	3	3	
Poles	2	2	2	
Frequency [Hz]	60	50	50	
Rated voltage [V]	230/460	190/380	220/415	
Rated current [A]	7.18/3.59	8.78/4.39	7.83/4.15	
L. R. Amperes [A]	57.4/28.7	53.6/26.8	53.2/28.2	
LRC [A]	8.0x(Code J)	6.1x(Code G)	6.8x(Code H)	
No load current [A]	2.60/1.30	2.60/1.30	2.71/1.44	
Rated speed [RPM]	3480	2825	2840	
Slip [%]	3.33	5.83	5.33	
Rated torque [ft.lb]	4.53	5.58	5.55	
Locked rotor torque [%]	229	190	220	
Breakdown torque [%]	300	229	250	
Service factor		1.00	1.00	
Temperature rise	80 K	105 K	105 K	
Locked rotor time	16s (cold) 9s (hot)	0s (cold) 0s (hot)	0s (cold) 0s (hot)	
Noise level ²	62.0 dB(A)	60.0 dB(A)	60.0 dB(A)	
Efficiency (%)	25%	83.7	88.4	
	50%	84.0	86.5	
	75%	85.5	85.6	
	100%	85.5	83.2	
Power Factor	25%	0.50	0.51	
	50%	0.76	0.79	
	75%	0.86	0.88	
	100%	0.90	0.92	
Bearing type	: <u>Drive end</u> 6205 ZZ <u>Non drive end</u> 6203 ZZ	Foundation loads		
Sealing	: Without Without Bearing Seal Bearing Seal	Max. traction	: 100 lb	
		Max. compression	: 141 lb	
Lubrication interval	: - -			
Lubricant amount	: - -			
Lubricant type	: Mobil Polyrex EM			
Notes USABLE @208V 7.94A SF 1.00 SFA 7.94A				
This revision replaces and cancel the previous one, which must be eliminated. (1) Looking the motor from the shaft end. (2) Measured at 1m and with tolerance of +3dB(A). (3) Approximate weight subject to changes after manufacturing process. (4) At 100% of full load.		These are average values based on tests with sinusoidal power supply, subject to the tolerances stipulated in NEMA MG-1.		
Rev.	Changes Summary	Performed	Checked	Date
Performed by				
Checked by			Page	Revision
Date	13/04/2022		1 /	

TORQUE AND CURRENT VS SPEED CURVE

Three Phase Induction Motor - Squirrel Cage



Customer :

Product line : NEMA Premium Efficiency Three-Phase

Product code : 12674940

Catalog # : 003360T3E145T-SG

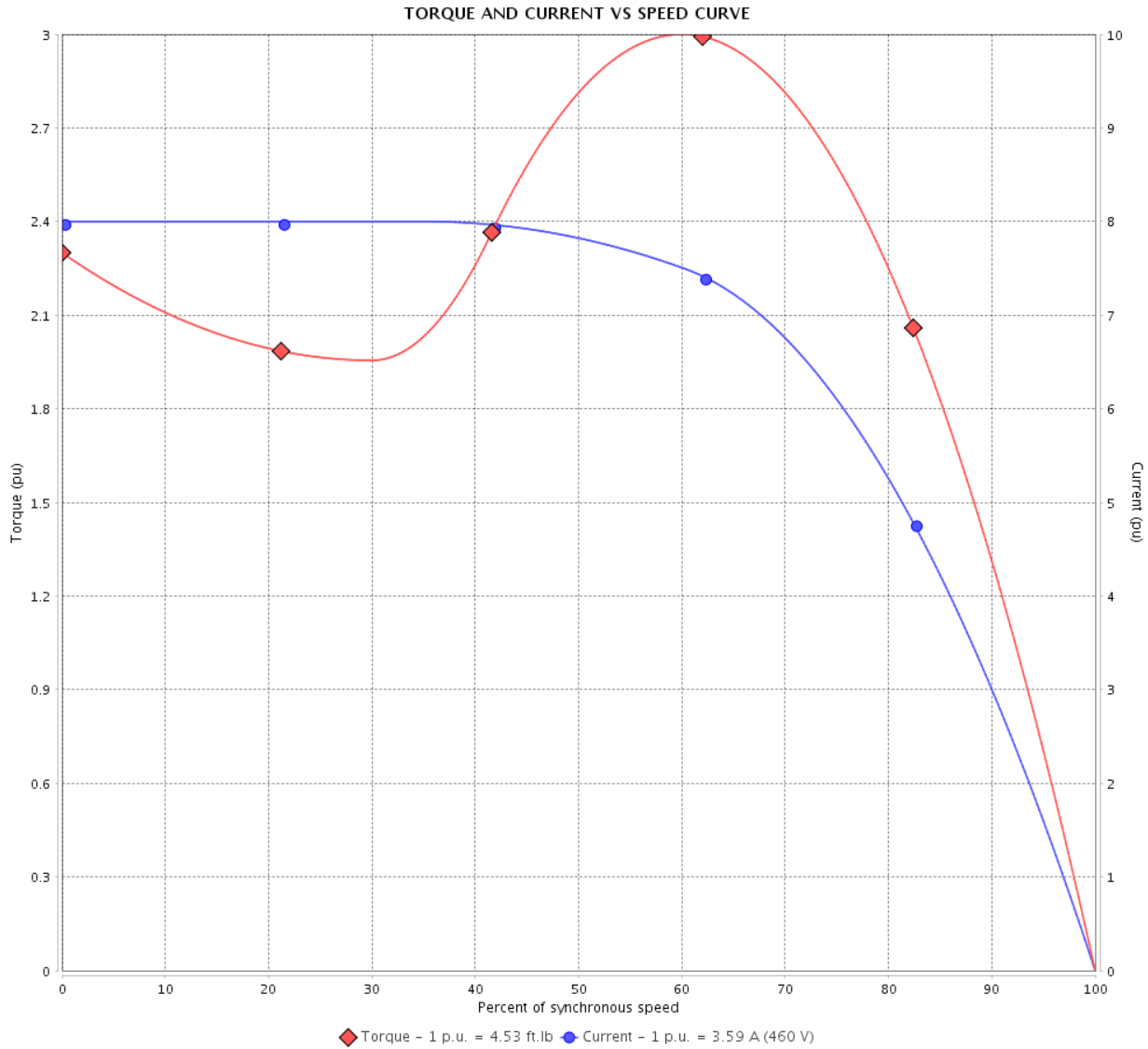

Performance : 230/460 V 60 Hz 2P

Rated current	: 7.18/3.59 A	Moment of inertia (J)	: 0.1279 sq.ft.lb
LRC	: 8.0	Duty cycle	: Cont.(S1)
Rated torque	: 4.53 ft.lb	Insulation class	: F
Locked rotor torque	: 229 %	Service factor	:
Breakdown torque	: 300 %	Temperature rise	: 80 K
Rated speed	: 3480 rpm	Design	: B

Locked rotor time : 16s (cold) 9s (hot)

Rev.	Changes Summary	Performed	Checked	Date
Performed by			Page 2 /	Revision
Checked by				
Date	13/04/2022			

TORQUE AND CURRENT VS SPEED CURVE



Three Phase Induction Motor - Squirrel Cage

Customer :

Product line : NEMA Premium Efficiency Three-Phase

Product code : 12674940

Catalog # : 00336OT3E145T-SG

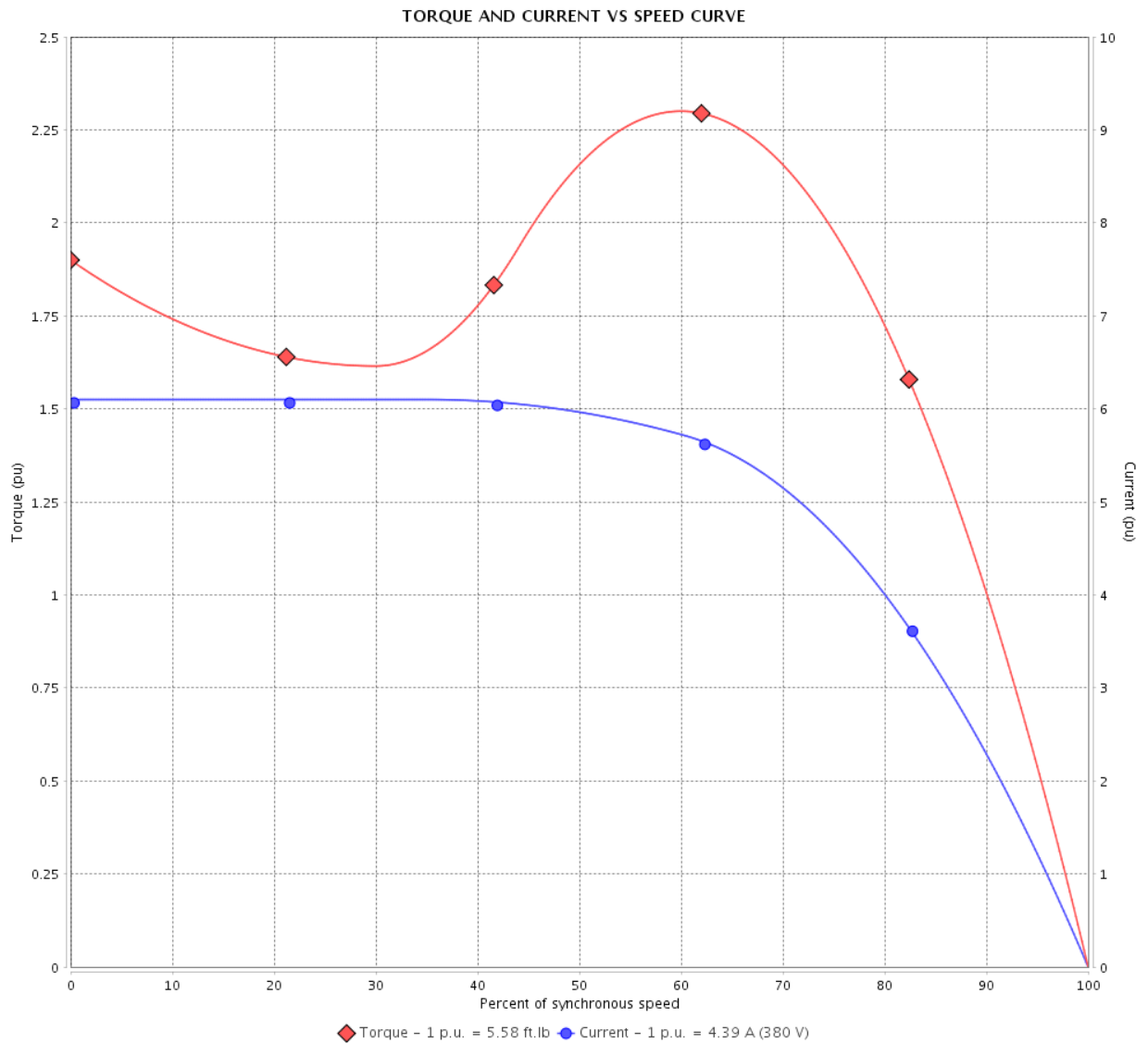

Performance : 190/380 V 50 Hz 2P

Rated current : 8.78/4.39 A
 LRC : 6.1
 Rated torque : 5.58 ft.lb
 Locked rotor torque : 190 %
 Breakdown torque : 229 %
 Rated speed : 2825 rpm

Moment of inertia (J) : 0.1279 sq.ft.lb
 Duty cycle : Cont.(S1)
 Insulation class : F
 Service factor : 1.00
 Temperature rise : 105 K
 Design : B

Locked rotor time : 0s (cold) 0s (hot)

Rev.	Changes Summary	Performed	Checked	Date
Performed by			Page 3 /	Revision
Checked by				
Date	13/04/2022			

TORQUE AND CURRENT VS SPEED CURVE

Three Phase Induction Motor - Squirrel Cage



Customer :

Product line : NEMA Premium Efficiency Three-Phase

Product code : 12674940

Catalog # : 003360T3E145T-SG

TORQUE AND CURRENT VS SPEED CURVE

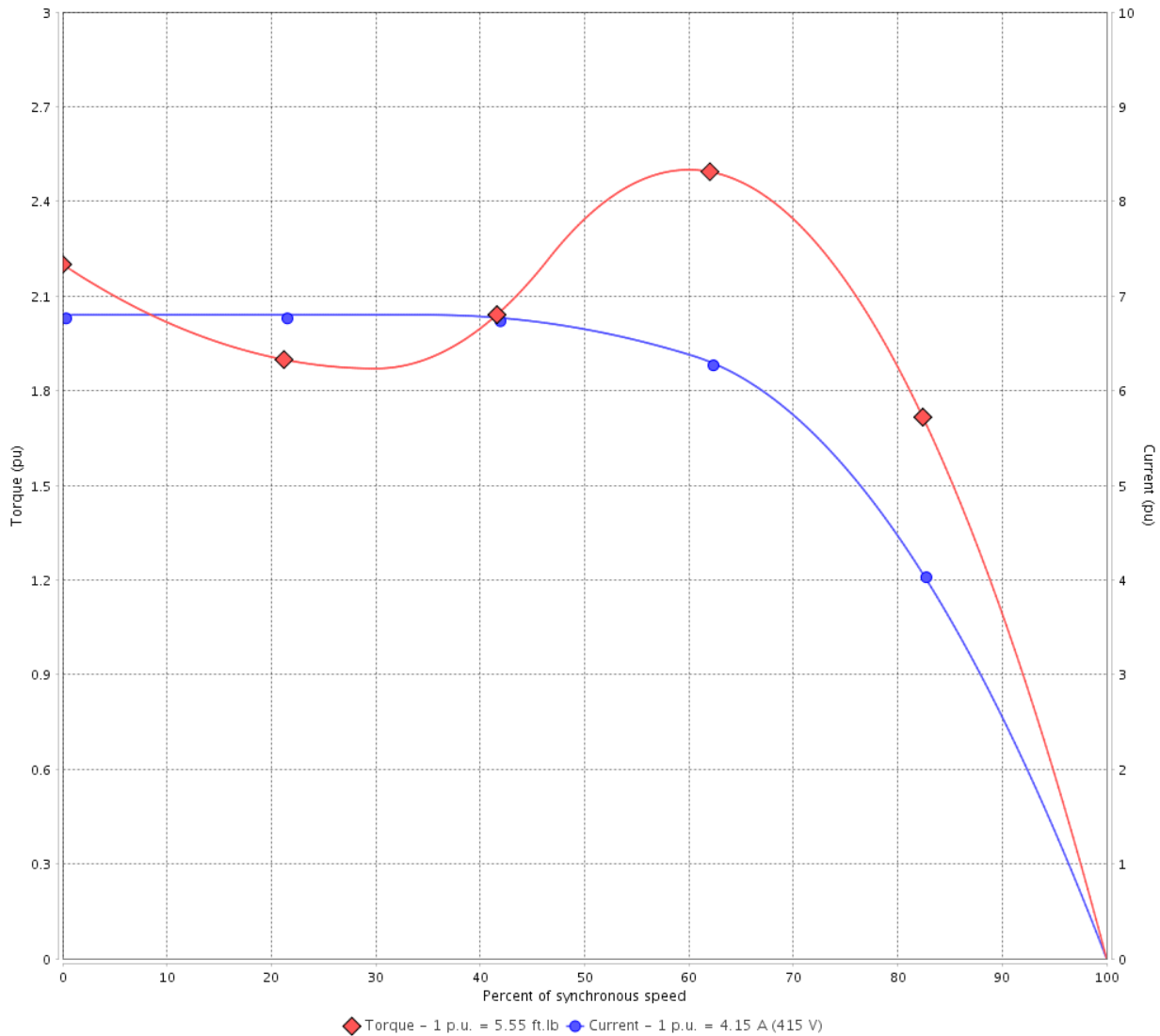

Performance : 220/415 V 50 Hz 2P

Rated current	: 7.83/4.15 A	Moment of inertia (J)	: 0.1279 sq.ft.lb
LRC	: 6.8	Duty cycle	: Cont.(S1)
Rated torque	: 5.55 ft.lb	Insulation class	: F
Locked rotor torque	: 220 %	Service factor	: 1.00
Breakdown torque	: 250 %	Temperature rise	: 105 K
Rated speed	: 2840 rpm	Design	: B

Locked rotor time : 0s (cold) 0s (hot)

Rev.	Changes Summary	Performed	Checked	Date
Performed by			Page 4 /	Revision
Checked by				
Date	13/04/2022			

LOAD PERFORMANCE CURVE

Three Phase Induction Motor - Squirrel Cage



Customer :

Product line : NEMA Premium Efficiency Three-Phase

Product code : 12674940

Catalog # : 00336OT3E145T-SG

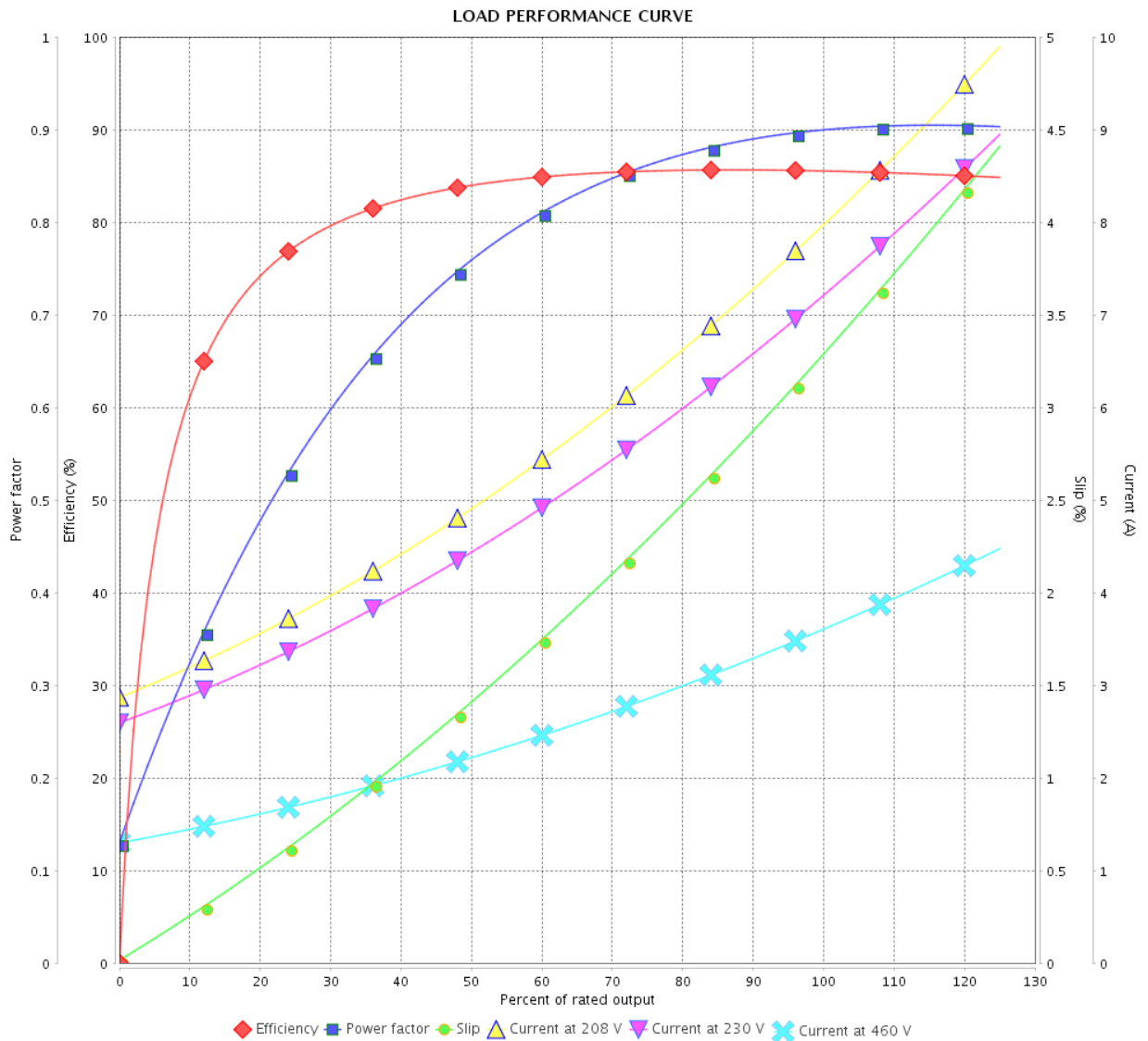

Performance : 230/460 V 60 Hz 2P

Rated current : 7.18/3.59 A
 LRC : 8.0
 Rated torque : 4.53 ft.lb
 Locked rotor torque : 229 %
 Breakdown torque : 300 %
 Rated speed : 3480 rpm

Moment of inertia (J) : 0.1279 sq.ft.lb
 Duty cycle : Cont.(S1)
 Insulation class : F
 Service factor :
 Temperature rise : 80 K
 Design : B

Rev.	Changes Summary	Performed	Checked	Date
Performed by				
Checked by			Page	Revision
Date	13/04/2022		5 /	

LOAD PERFORMANCE CURVE

Three Phase Induction Motor - Squirrel Cage



Customer :

Product line : NEMA Premium Efficiency Three-Phase

Product code : 12674940

Catalog # : 00336OT3E145T-SG

LOAD PERFORMANCE CURVE

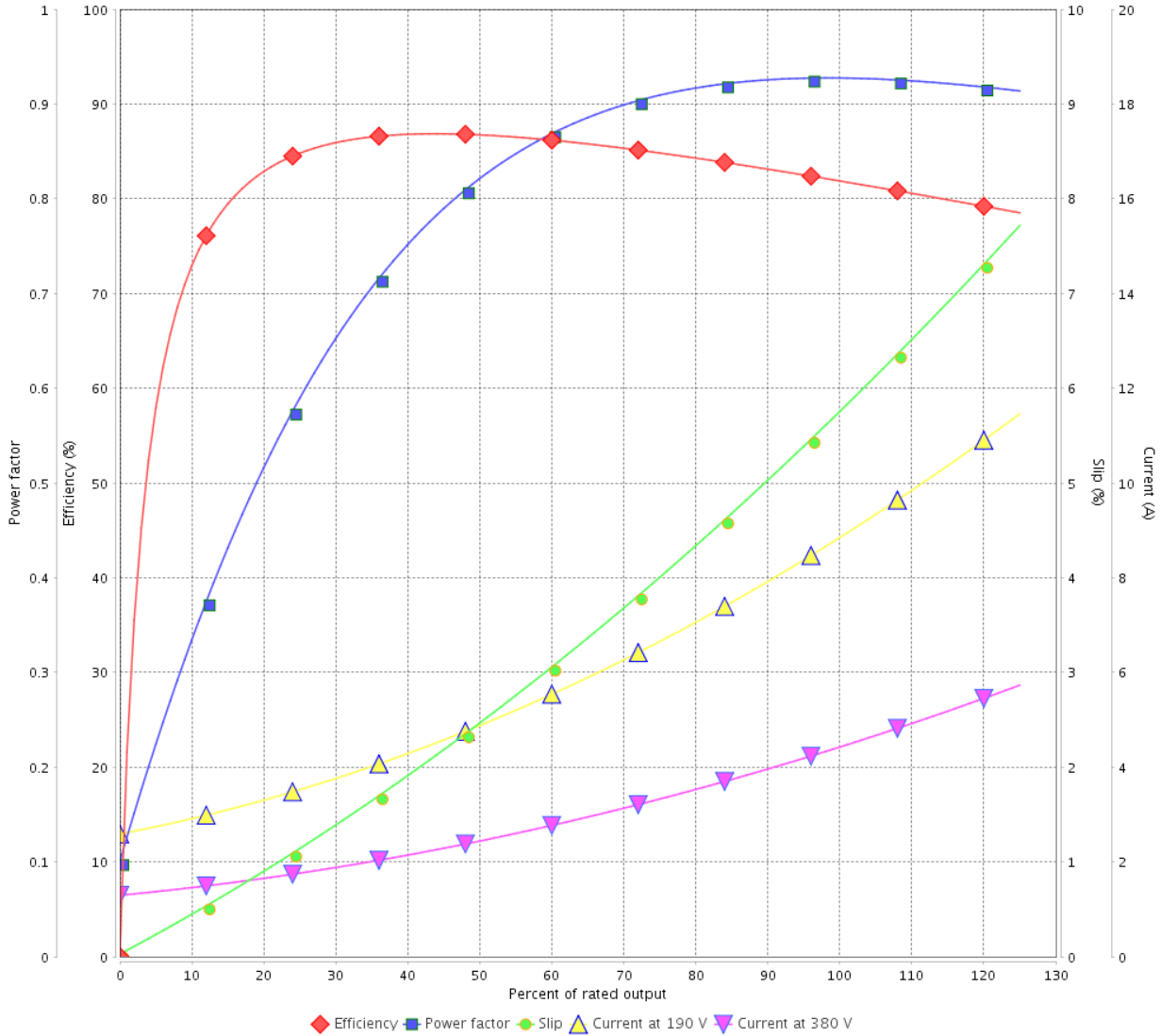

Performance : 190/380 V 50 Hz 2P

Rated current : 8.78/4.39 A
 LRC : 6.1
 Rated torque : 5.58 ft.lb
 Locked rotor torque : 190 %
 Breakdown torque : 229 %
 Rated speed : 2825 rpm

Moment of inertia (J) : 0.1279 sq.ft.lb
 Duty cycle : Cont.(S1)
 Insulation class : F
 Service factor : 1.00
 Temperature rise : 105 K
 Design : B

Rev.	Changes Summary	Performed	Checked	Date
Performed by			Page	Revision
Checked by			6 /	
Date	13/04/2022			

LOAD PERFORMANCE CURVE

Three Phase Induction Motor - Squirrel Cage



Customer :

Product line : NEMA Premium Efficiency Three-Phase

Product code : 12674940

Catalog # : 00336OT3E145T-SG

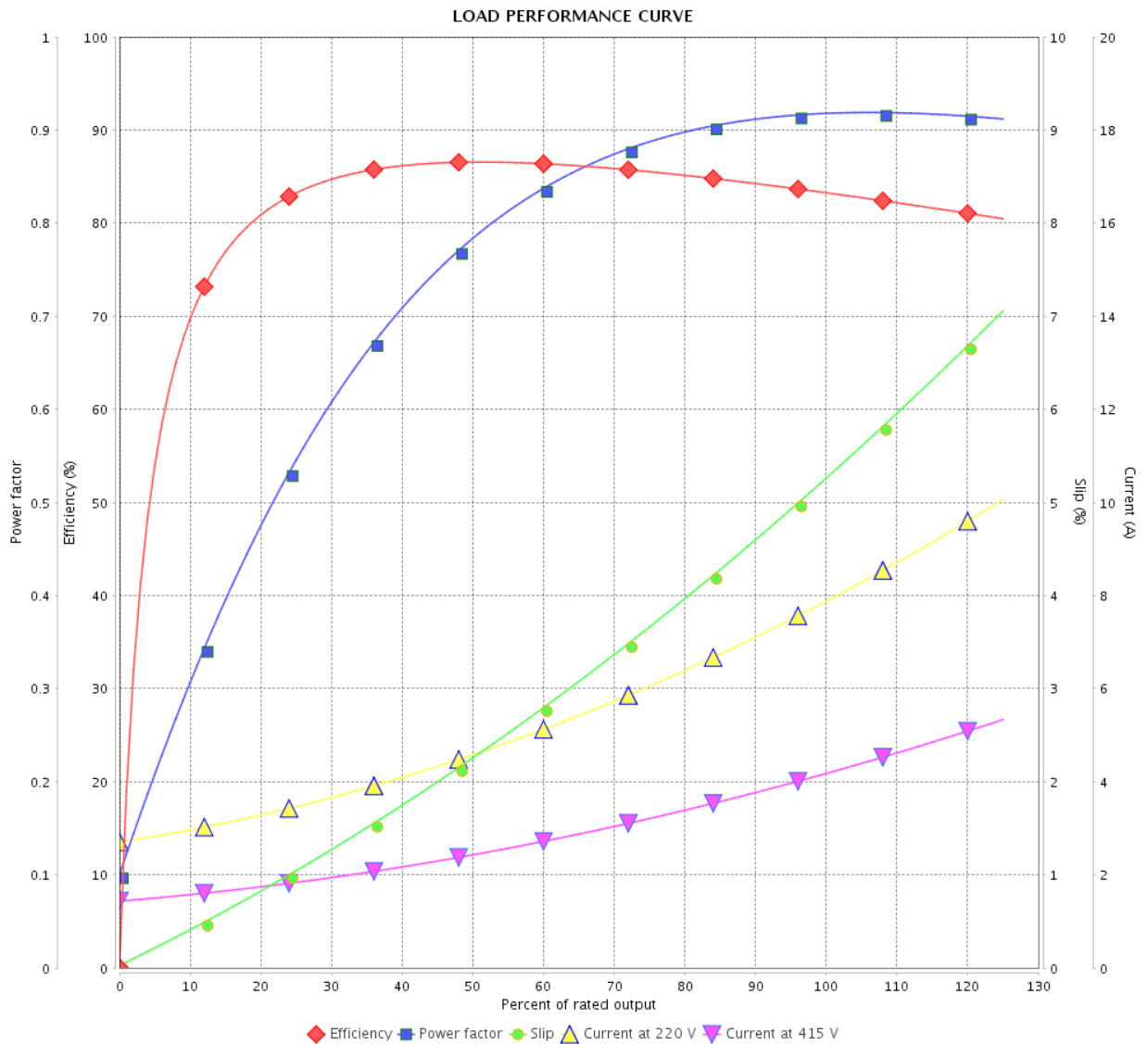

Performance : 220/415 V 50 Hz 2P

Rated current : 7.83/4.15 A
 LRC : 6.8
 Rated torque : 5.55 ft.lb
 Locked rotor torque : 220 %
 Breakdown torque : 250 %
 Rated speed : 2840 rpm

Moment of inertia (J) : 0.1279 sq.ft.lb
 Duty cycle : Cont.(S1)
 Insulation class : F
 Service factor : 1.00
 Temperature rise : 105 K
 Design : B

Rev.	Changes Summary	Performed	Checked	Date
Performed by		Page		Revision
Checked by		7 /		
Date		13/04/2022		

THERMAL LIMIT CURVE



Three Phase Induction Motor - Squirrel Cage

Customer :

Product line : NEMA Premium Efficiency Three-Phase
Product code : 12674940
Catalog # : 00336OT3E145T-SG

Performance : 230/460 V 60 Hz 2P

Rated current	: 7.18/3.59 A	Moment of inertia (J)	: 0.1279 sq.ft.lb
LRC	: 8.0	Duty cycle	: Cont.(S1)
Rated torque	: 4.53 ft.lb	Insulation class	: F
Locked rotor torque	: 229 %	Service factor	:
Breakdown torque	: 300 %	Temperature rise	: 80 K
Rated speed	: 3480 rpm	Design	: B

Heating constant

Cooling constant

Rev.	Changes Summary	Performed	Checked	Date
Performed by				
Checked by			Page	Revision
Date	13/04/2022		8 /	

THERMAL LIMIT CURVE

Three Phase Induction Motor - Squirrel Cage



Customer : _____

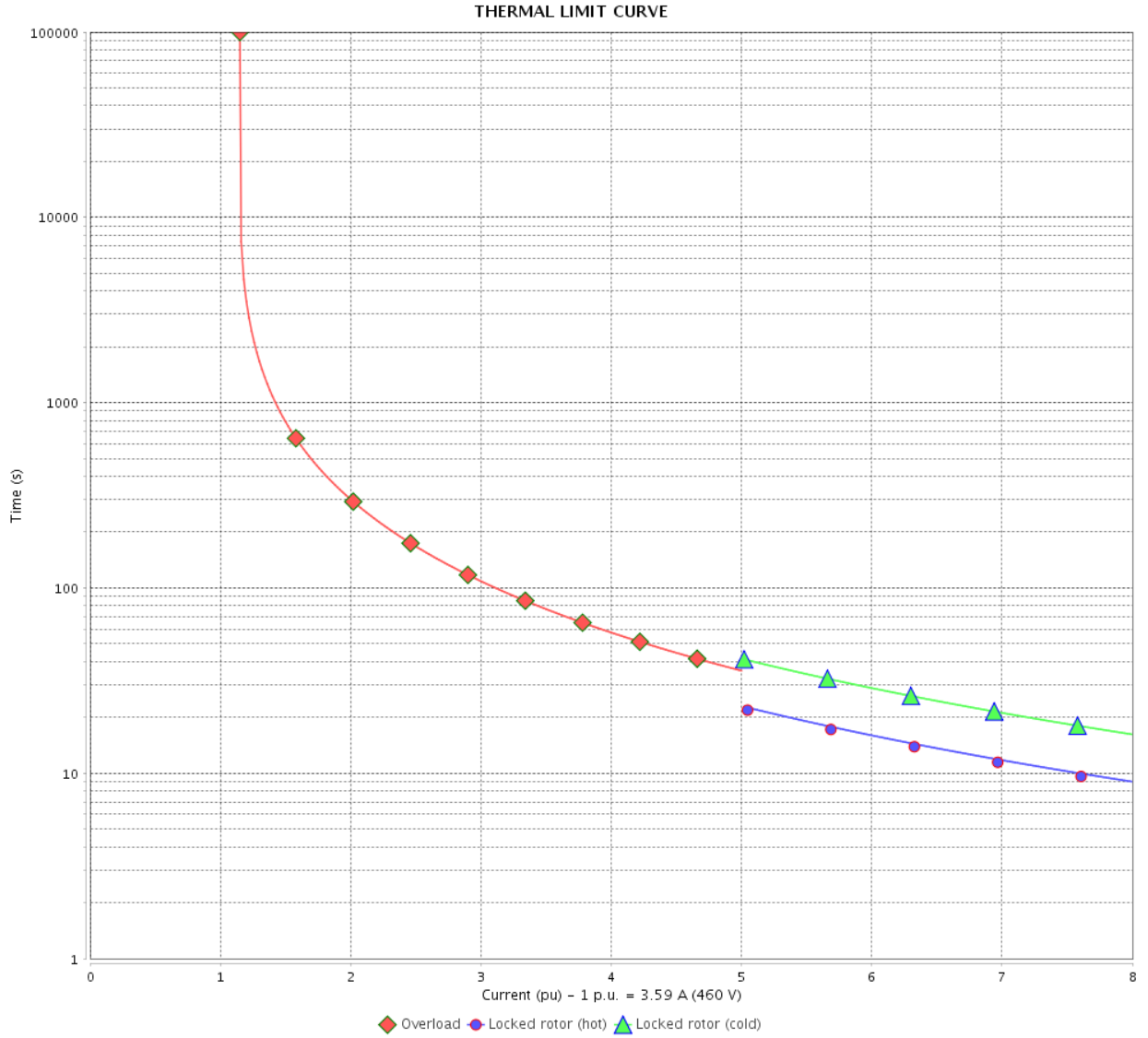

Rev.	Changes Summary	Performed	Checked	Date
Performed by		Page 9 /		Revision
Checked by				
Date				

THERMAL LIMIT CURVE



Three Phase Induction Motor - Squirrel Cage

Customer :

Product line : NEMA Premium Efficiency Three-Phase
 Product code : 12674940
 Catalog # : 00336OT3E145T-SG

Performance : 190/380 V 50 Hz 2P

Rated current : 8.78/4.39 A	Moment of inertia (J) : 0.1279 sq.ft.lb
LRC : 6.1	Duty cycle : Cont.(S1)
Rated torque : 5.58 ft.lb	Insulation class : F
Locked rotor torque : 190 %	Service factor : 1.00
Breakdown torque : 229 %	Temperature rise : 105 K
Rated speed : 2825 rpm	Design : B

Heating constant

Cooling constant

Rev.	Changes Summary	Performed	Checked	Date
Performed by			Page 10 /	Revision
Checked by				
Date	13/04/2022			

THERMAL LIMIT CURVE

Three Phase Induction Motor - Squirrel Cage



Customer : _____

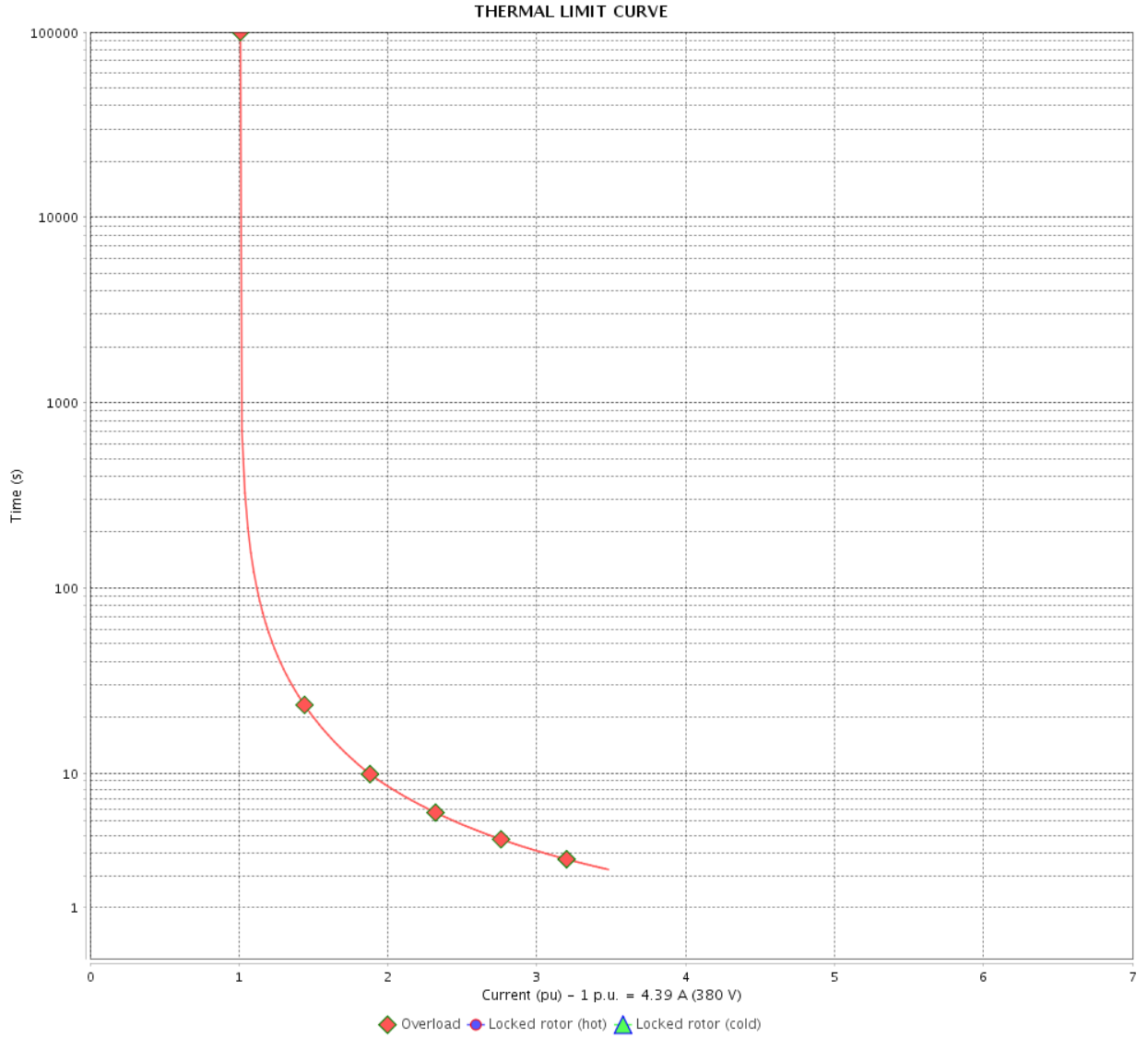

Rev.	Changes Summary	Performed	Checked	Date
Performed by		Page		Revision
Checked by		11 /		
Date		13/04/2022		

THERMAL LIMIT CURVE

Three Phase Induction Motor - Squirrel Cage



Customer :

Product line : NEMA Premium Efficiency Three-Phase
Product code : 12674940
Catalog # : 00336OT3E145T-SG

Performance : 220/415 V 50 Hz 2P

Rated current	: 7.83/4.15 A	Moment of inertia (J)	: 0.1279 sq.ft.lb
LRC	: 6.8	Duty cycle	: Cont.(S1)
Rated torque	: 5.55 ft.lb	Insulation class	: F
Locked rotor torque	: 220 %	Service factor	: 1.00
Breakdown torque	: 250 %	Temperature rise	: 105 K
Rated speed	: 2840 rpm	Design	: B

Heating constant

Cooling constant

Rev.	Changes Summary	Performed	Checked	Date
Performed by				
Checked by			Page	Revision
Date	13/04/2022		12 /	

THERMAL LIMIT CURVE

Three Phase Induction Motor - Squirrel Cage



Customer : _____

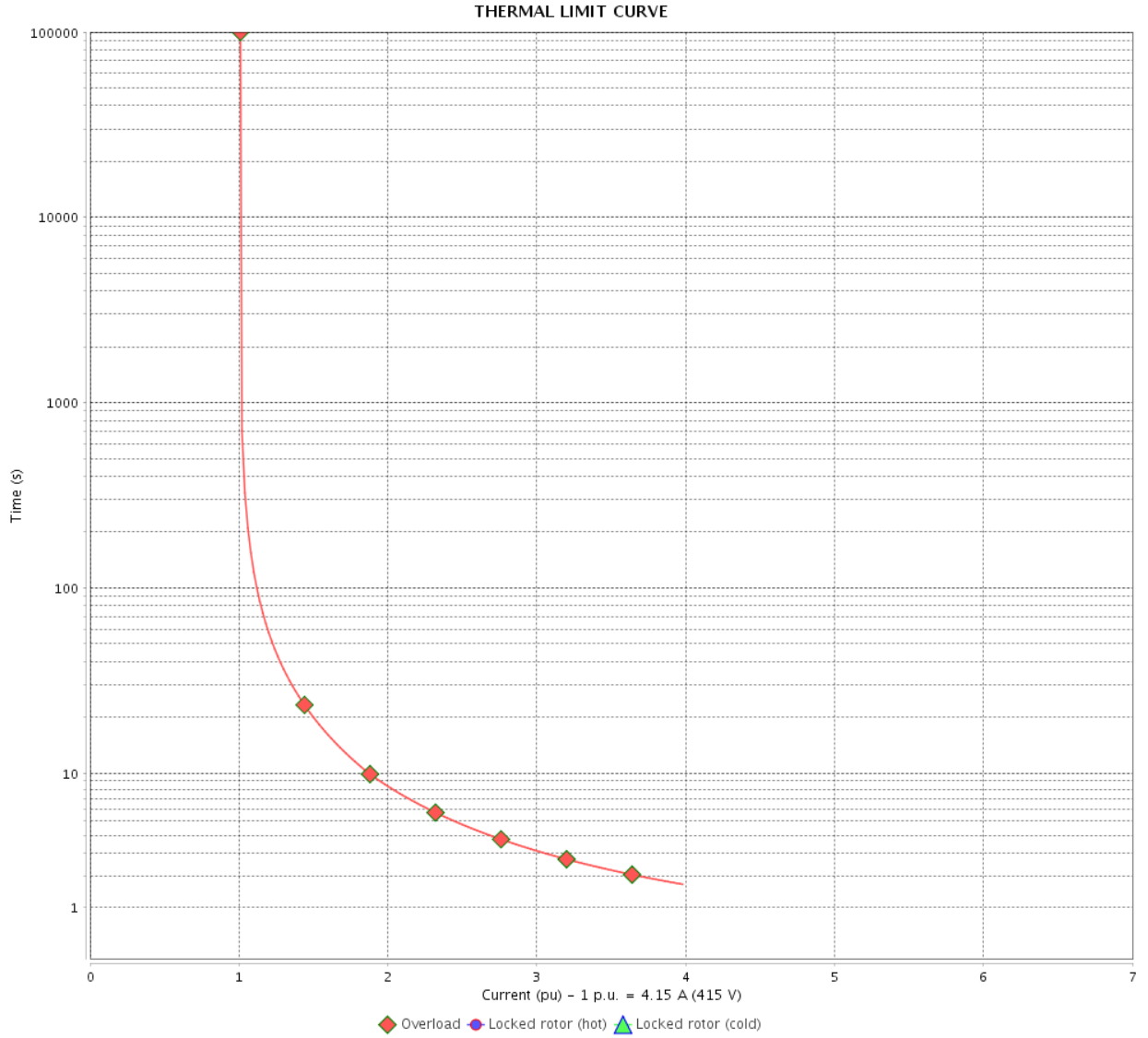

Rev.	Changes Summary	Performed	Checked	Date
Performed by		Page		Revision
Checked by		13 /		
Date		13/04/2022		

VFD OPERATION CURVE

Three Phase Induction Motor - Squirrel Cage



Customer :

Product line : NEMA Premium Efficiency Three-Phase

Product code : 12674940

Catalog # : 00336OT3E145T-SG

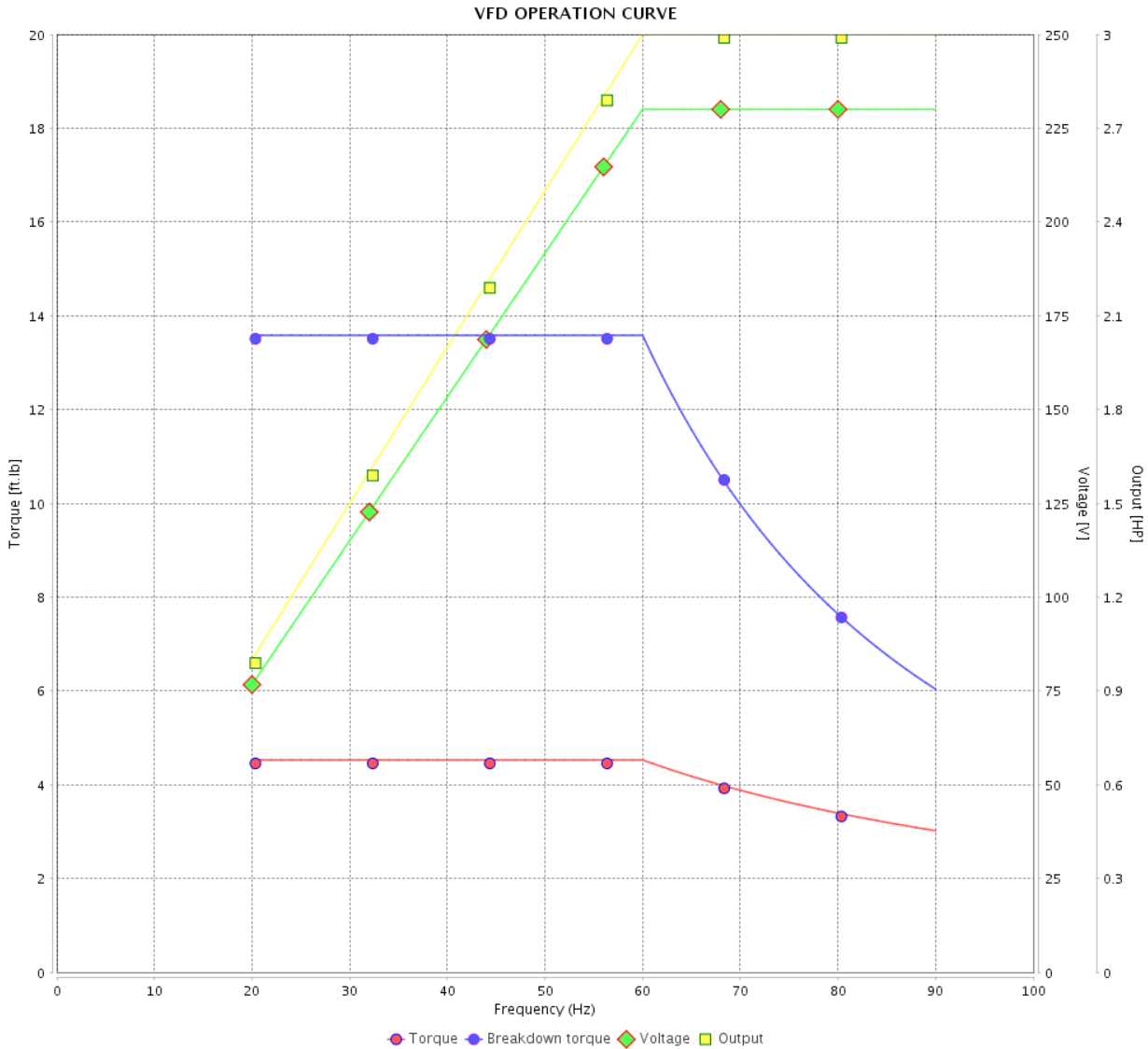

Performance : 230/460 V 60 Hz 2P

Rated current : 7.18/3.59 A
 LRC : 8.0
 Rated torque : 4.53 ft.lb
 Locked rotor torque : 229 %
 Breakdown torque : 300 %
 Rated speed : 3480 rpm

Moment of inertia (J) : 0.1279 sq.ft.lb
 Duty cycle : Cont.(S1)
 Insulation class : F
 Service factor :
 Temperature rise : 80 K
 Design : B

Rev.	Changes Summary	Performed	Checked	Date
Performed by			Page	Revision
Checked by				
Date				

1 2 3 4 5 6

A

B

C

D

E

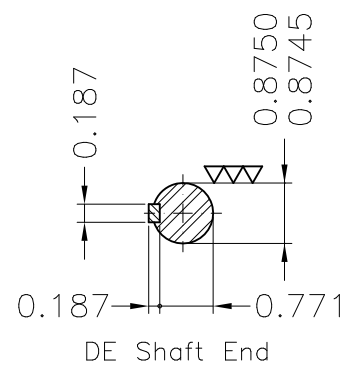
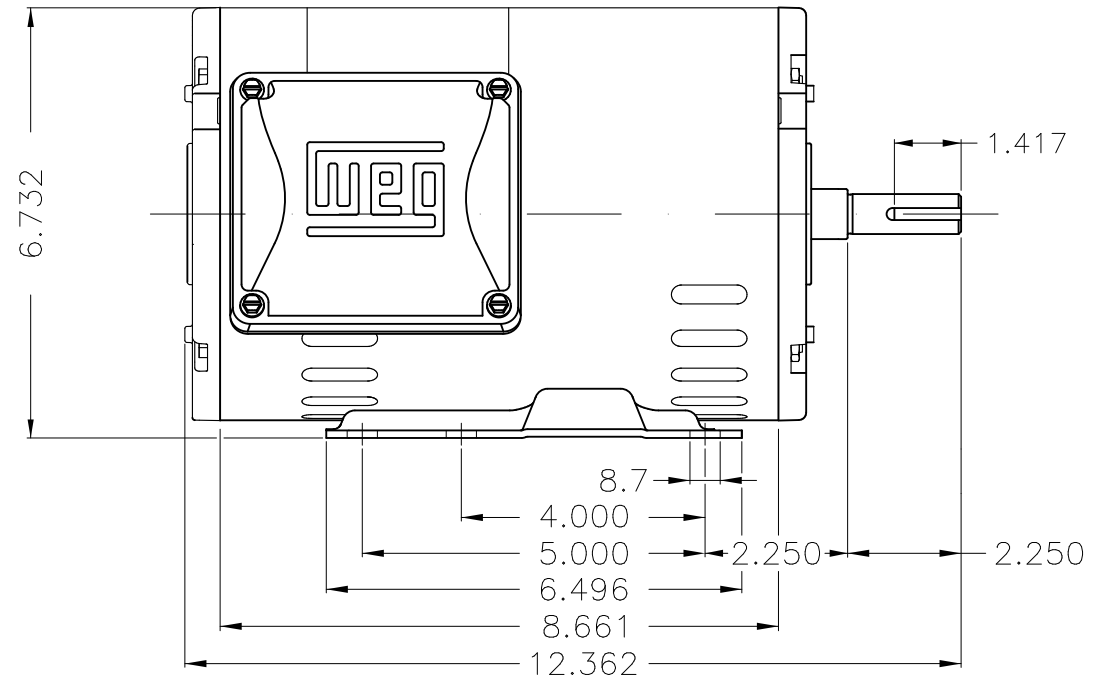
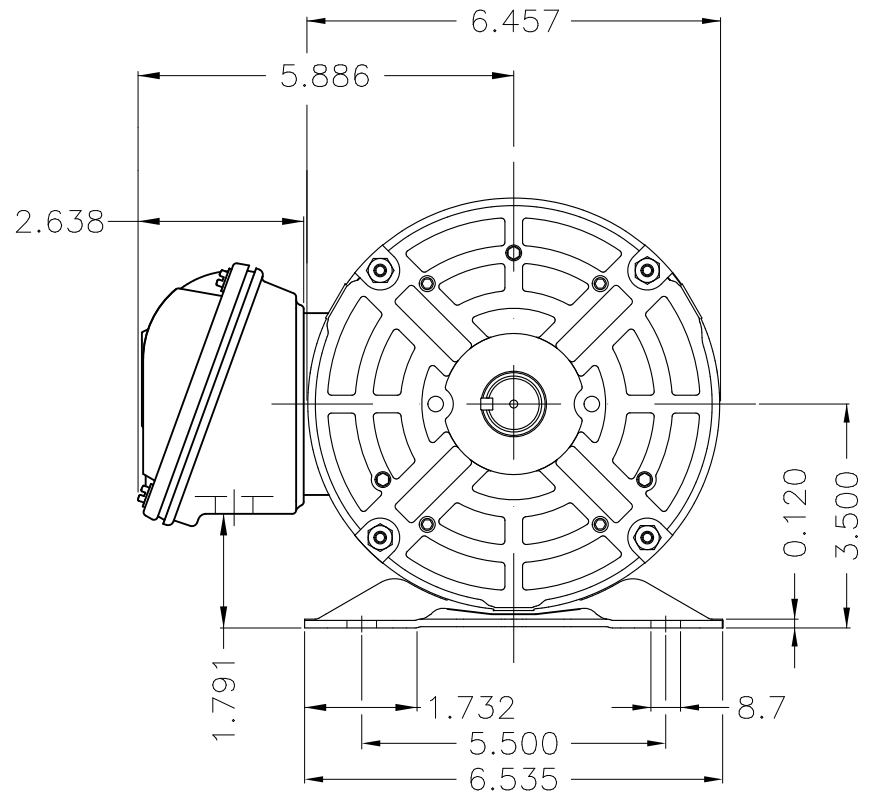
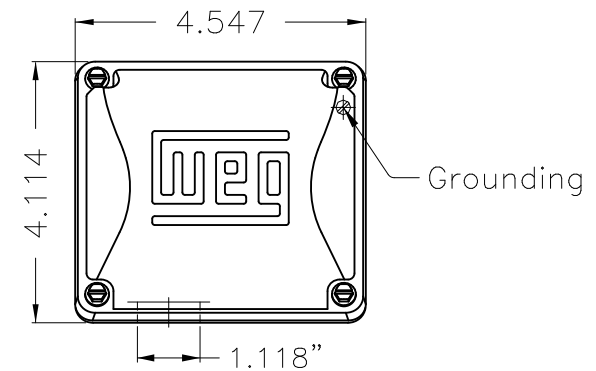

Bearing cap
 Internal AEGIS ground ring on the DE
 Color Munsell N 1 matte black
 Painting plan 207N
 Mounting F-1/B3R(D)

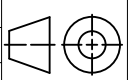
ECM	LOC	SUMMARY OF MODIFICATIONS	EXECUTED	CHECKED	RELEASED	DATE	VER
EXECUTED	PIRWBUSER	 THREE PH. MOTOR ROLLED STEEL PREM. EFF. FRAME 143/5T IP21 ODP					
CHECKED							
RELEASED							
REL DT.	WMO	Jaragua do Sul	Product Engineering	SHEET	1 / 1		

3 HP 02 Poles 60 Hz

A

PREVIEW

WDD



Dimensions in inches XME A3

**NEMA**
Premium

3PT9



Energy Verified

MADE IN MEXICO

MAT: 12674940 CC029A**W01.T00IC0X0N****MODEL 003360T3E145T-SG****06APR2022 B/N:**

PH 3	Hz 60	HP 3.0
FR 143/5T		KW 2.2
DUTY CONT.		V 230/460
ALT 1000 m.a.s.l.		A 7.18/3.59
INS CL F AT 80K		SFA 8.26/4.13
AMB 40°C	DES B	SF 1.15
ENCL ODP	CODE J	PF 0.90
USABLE @ 208V 7.94A		RPM 3480
SF1.00		NEMA NOM. EFF 85.5%

ALTERNATE RATING: 3.0HP 50Hz 190-220/380-415V SF1.00
8.78-7.56/4.39-4.01A 2825RPM EFF 81.8% (IE1) IEC 60034-1

Inverter duty motor For 80Hz use on VPWM 1000:1 VT, 3:1 CT

DE 6205-ZZ	ODE 6203-ZZ	MOBIL POLYREX EM
-------------------	--------------------	-------------------------



T1-BLU T2-WHT
 T3-ORG T4-YEL
 T5-BLK T6-GRY
 T7-PNK T8-RED
 T9-BRK RED

INTERCHANGE ANY TWO LINE WIRES TO REVERSE THE ROTATION

WARNING: Motor must be grounded in accordance with local and national electrical codes to prevent serious electrical shocks. Disconnect power source before servicing unit.



AVERTISSEMENT: Le moteur doit être mis à la terre conformément aux codes électriques locaux et nationaux afin d'éviter tout choc électrique grave. Déconnectez l'alimentation avant l'entretien de la machine.

