

DATA SHEET



Three Phase Induction Motor - Squirrel Cage

Customer :

Product line : JM Pump NEMA Premium Efficiency Three-Phase Product code : 14327889
 Catalog # : 00336OT3V145JM-SG

Frame : 143/5JM Output : 3 HP (2.2 kW) Poles : 2 Frequency : 60 Hz Rated voltage : 200/400 V Rated current : 8.26/4.13 A L. R. Amperes : 66.1/33.0 A LRC : 8.0x(Code J) No load current : 2.99/1.49 A Rated speed : 3480 rpm Slip : 3.33 % Rated torque : 4.53 ft.lb Locked rotor torque : 229 % Breakdown torque : 300 % Insulation class : F Service factor : 1.15 Moment of inertia (J) : 0.1279 sq.ft.lb Design : B	Locked rotor time : 16s (cold) 9s (hot) Temperature rise : 80 K Duty cycle : Cont.(S1) Ambient temperature : -20°C to +40°C Altitude : 1000 m.a.s.l. Cooling method : IC01 - ODP Mounting : F-1 Rotation ¹ : Both (CW and CCW) Noise level ² : 62.0 dB(A) Starting method : Direct On Line Approx. weight ³ : 39.9 lb
--	--

Output	25%	50%	75%	100%	Foundation loads	
Efficiency (%)	83.7	84.0	85.5	85.5	Max. traction	: 98 lb
Power Factor	0.50	0.76	0.86	0.90	Max. compression	: 138 lb

	<u>Drive end</u>	<u>Non drive end</u>
Bearing type :	6206 ZZ	6203 ZZ
Sealing :	Without Bearing Seal	Without Bearing Seal
Lubrication interval :	-	-
Lubricant amount :	-	-
Lubricant type :	Mobil Polyrex EM	

Notes

This revision replaces and cancel the previous one, which must be eliminated.
 (1) Looking the motor from the shaft end.
 (2) Measured at 1m and with tolerance of +3dB(A).
 (3) Approximate weight subject to changes after manufacturing process.
 (4) At 100% of full load.

These are average values based on tests with sinusoidal power supply, subject to the tolerances stipulated in NEMA MG-1.

Rev.	Changes Summary	Performed	Checked	Date
Performed by		Page		Revision
Checked by		1 / 6		
Date	13/04/2022			

TORQUE AND CURRENT VS SPEED CURVE

Three Phase Induction Motor - Squirrel Cage



Customer :

Product line : JM Pump NEMA Premium
Efficiency Three-Phase

Product code : 14327889

Catalog # : 003360T3V145JM-SG

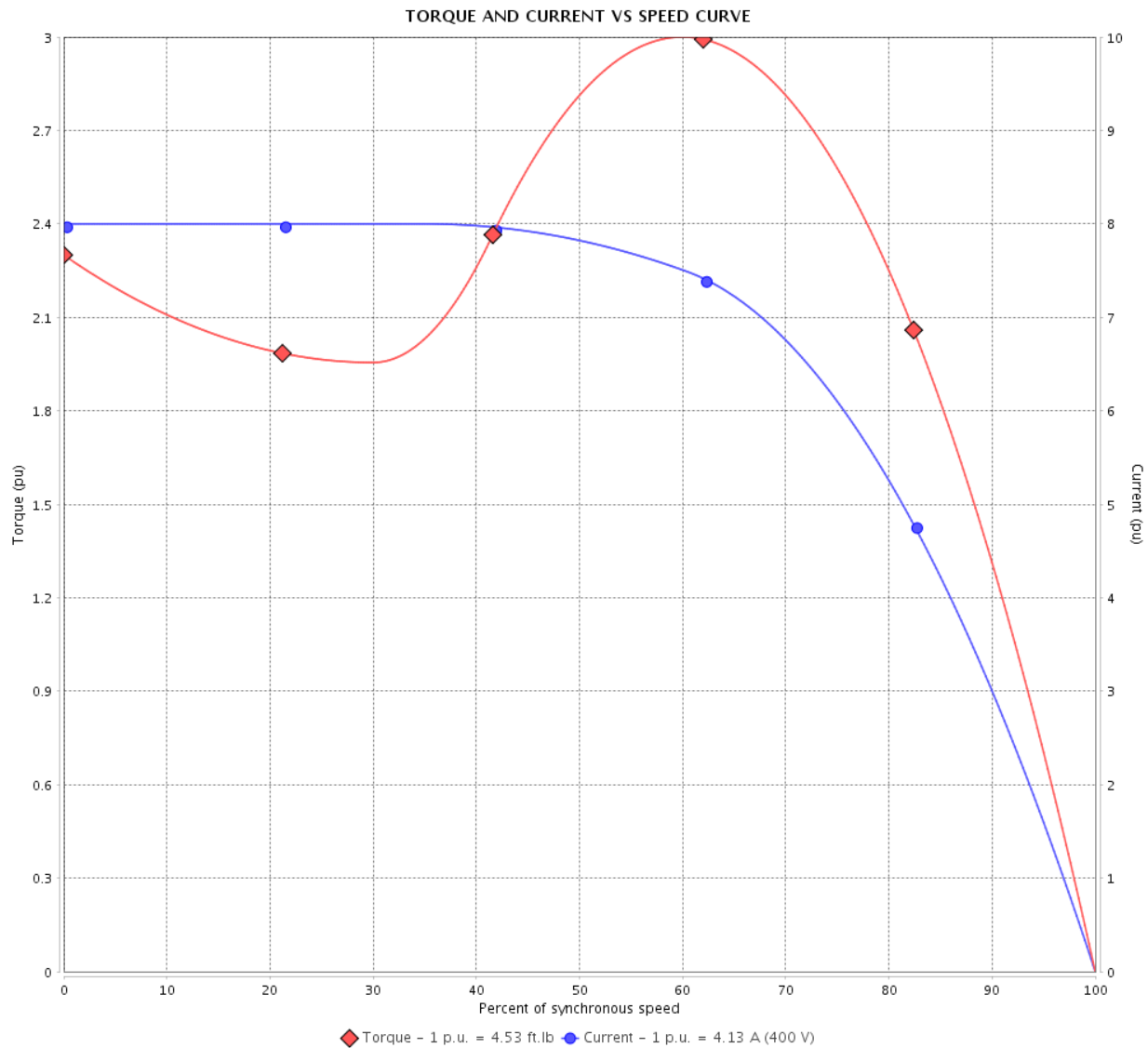

Performance : 200/400 V 60 Hz 2P

Rated current	: 8.26/4.13 A	Moment of inertia (J)	: 0.1279 sq.ft.lb
LRC	: 8.0	Duty cycle	: Cont.(S1)
Rated torque	: 4.53 ft.lb	Insulation class	: F
Locked rotor torque	: 229 %	Service factor	: 1.15
Breakdown torque	: 300 %	Temperature rise	: 80 K
Rated speed	: 3480 rpm	Design	: B

Locked rotor time : 16s (cold) 9s (hot)

Rev.	Changes Summary	Performed	Checked	Date
Performed by			Page 2 / 6	Revision
Checked by				
Date	13/04/2022			

LOAD PERFORMANCE CURVE

Three Phase Induction Motor - Squirrel Cage



Customer : _____

Product line : JM Pump NEMA Premium Efficiency Three-Phase

Product code : 14327889

Catalog # : 00336OT3V145JM-SG

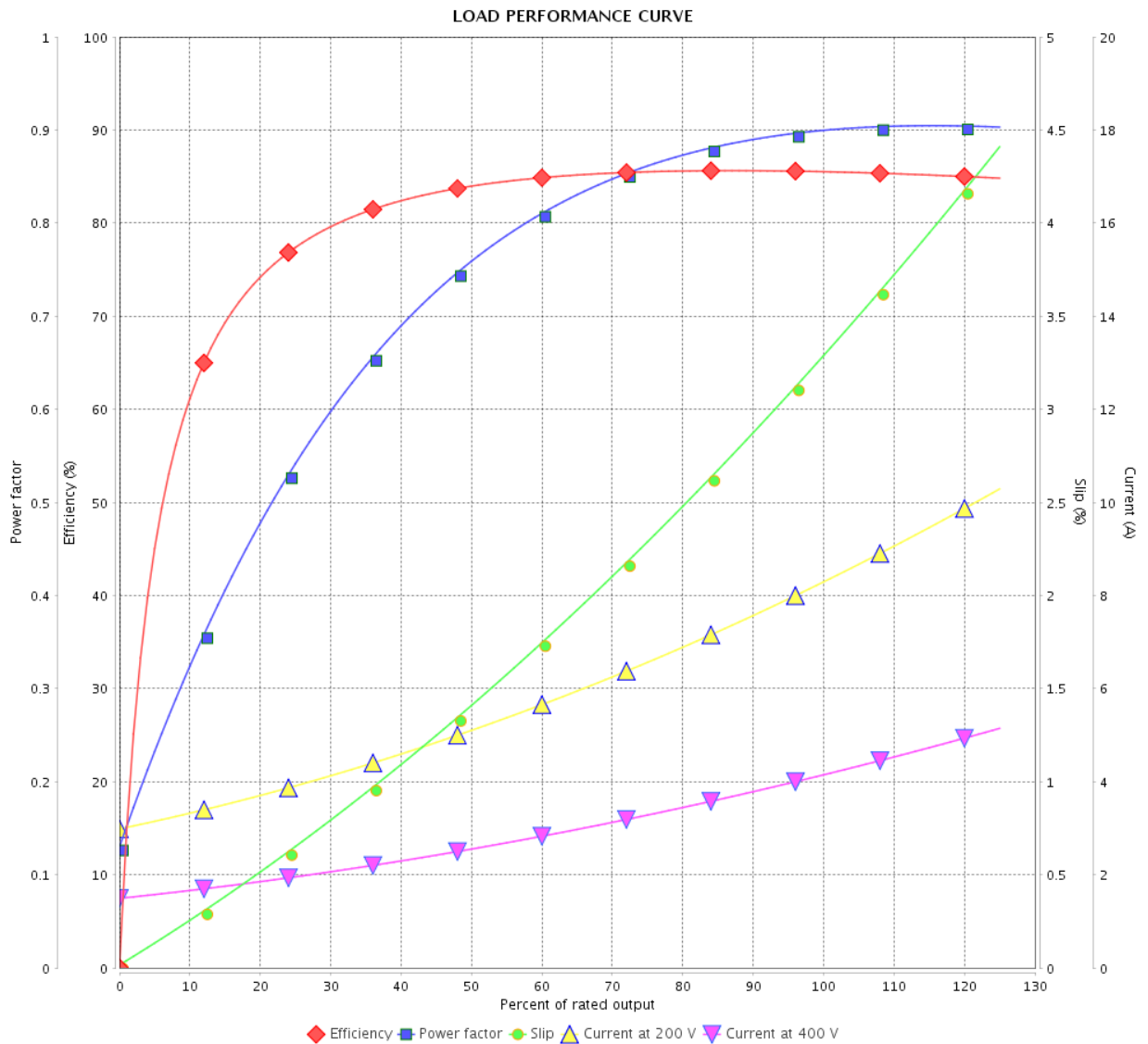

Performance : 200/400 V 60 Hz 2P

Rated current : 8.26/4.13 A
 LRC : 8.0
 Rated torque : 4.53 ft.lb
 Locked rotor torque : 229 %
 Breakdown torque : 300 %
 Rated speed : 3480 rpm

Moment of inertia (J) : 0.1279 sq.ft.lb
 Duty cycle : Cont.(S1)
 Insulation class : F
 Service factor : 1.15
 Temperature rise : 80 K
 Design : B

Rev.	Changes Summary	Performed	Checked	Date
Performed by		Page		Revision
Checked by		3 / 6		
Date		13/04/2022		

THERMAL LIMIT CURVE



Three Phase Induction Motor - Squirrel Cage

Customer :

Product line : JM Pump NEMA Premium
Efficiency Three-Phase

Product code : 14327889

Catalog # : 00336OT3V145JM-SG

Performance : 200/400 V 60 Hz 2P

Rated current : 8.26/4.13 A
LRC : 8.0
Rated torque : 4.53 ft.lb
Locked rotor torque : 229 %
Breakdown torque : 300 %
Rated speed : 3480 rpm

Moment of inertia (J) : 0.1279 sq.ft.lb
Duty cycle : Cont.(S1)
Insulation class : F
Service factor : 1.15
Temperature rise : 80 K
Design : B

Heating constant

Cooling constant

Rev.	Changes Summary	Performed	Checked	Date
Performed by				
Checked by			Page	Revision
Date	13/04/2022		4 / 6	

THERMAL LIMIT CURVE

Three Phase Induction Motor - Squirrel Cage



Customer : _____

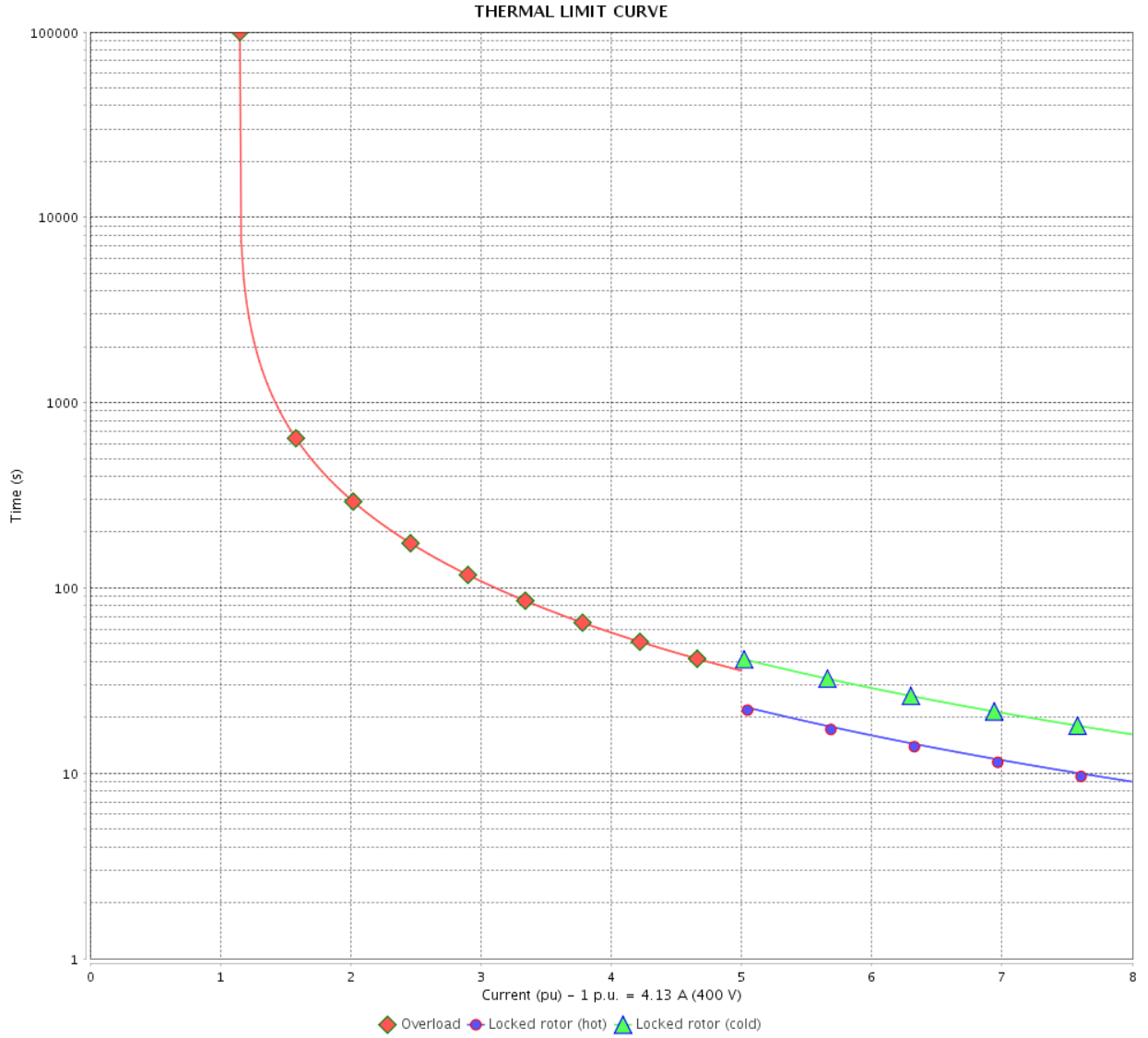

Rev.	Changes Summary	Performed	Checked	Date
Performed by				
Checked by				
Date				
			Page	Revision
			5 / 6	

VFD OPERATION CURVE

Three Phase Induction Motor - Squirrel Cage



Customer :

Product line : JM Pump NEMA Premium Efficiency Three-Phase

Product code : 14327889

Catalog # : 00336OT3V145JM-SG

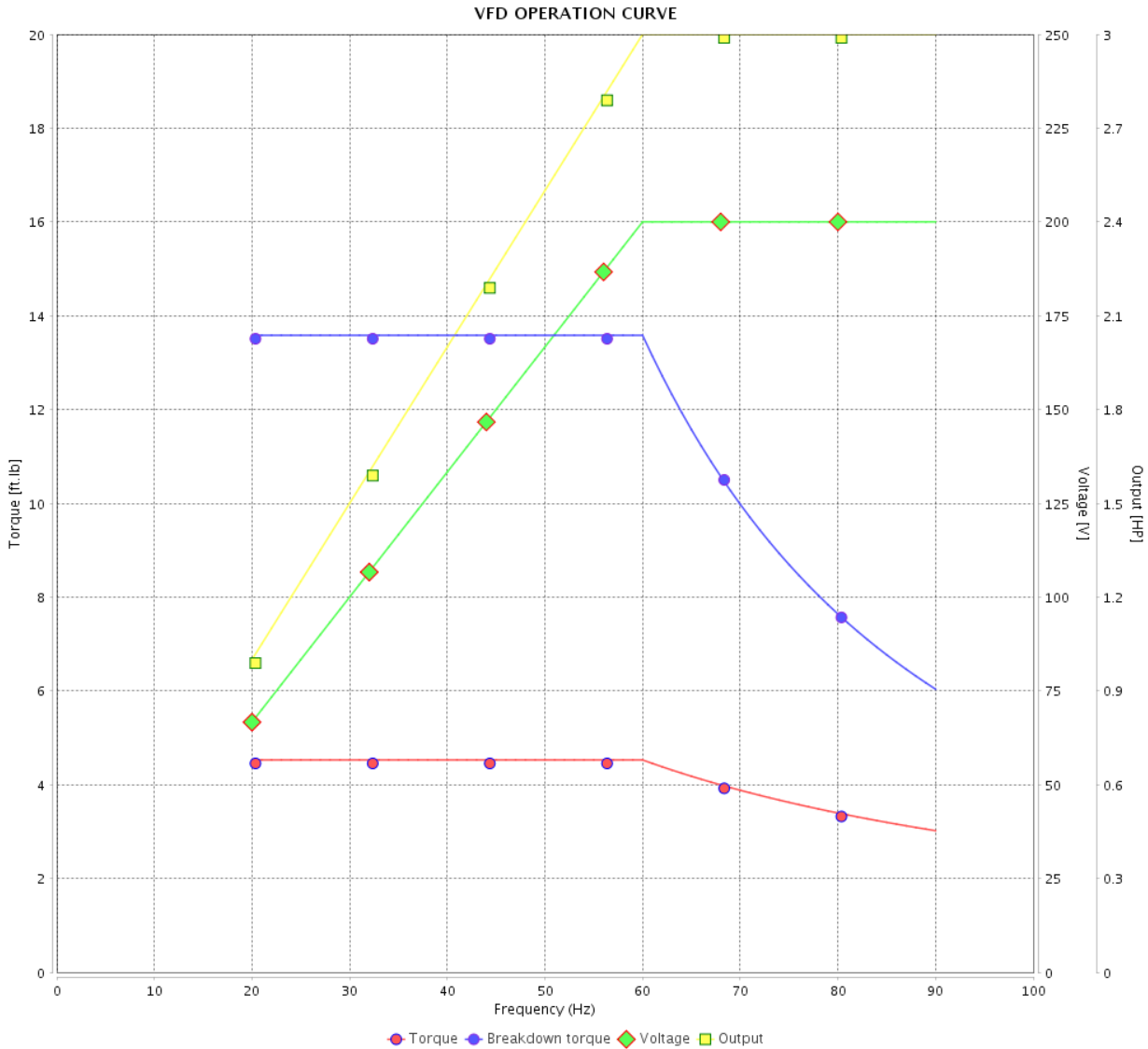

Performance : 200/400 V 60 Hz 2P

Rated current : 8.26/4.13 A
 LRC : 8.0
 Rated torque : 4.53 ft.lb
 Locked rotor torque : 229 %
 Breakdown torque : 300 %
 Rated speed : 3480 rpm

Moment of inertia (J) : 0.1279 sq.ft.lb
 Duty cycle : Cont.(S1)
 Insulation class : F
 Service factor : 1.15
 Temperature rise : 80 K
 Design : B

Rev.	Changes Summary	Performed	Checked	Date
Performed by			Page	Revision
Checked by			6 / 6	
Date	13/04/2022			

1 2 3 4 5 6

A

B

C

D

E

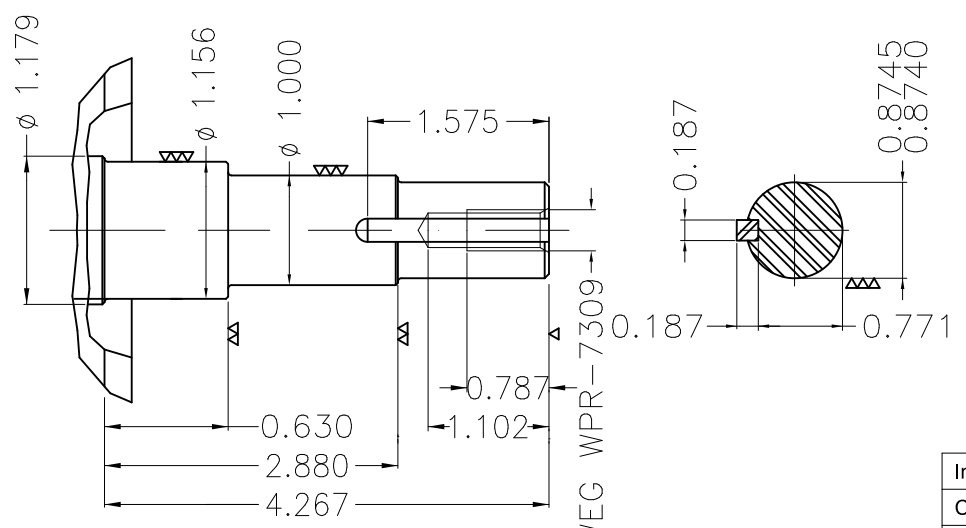
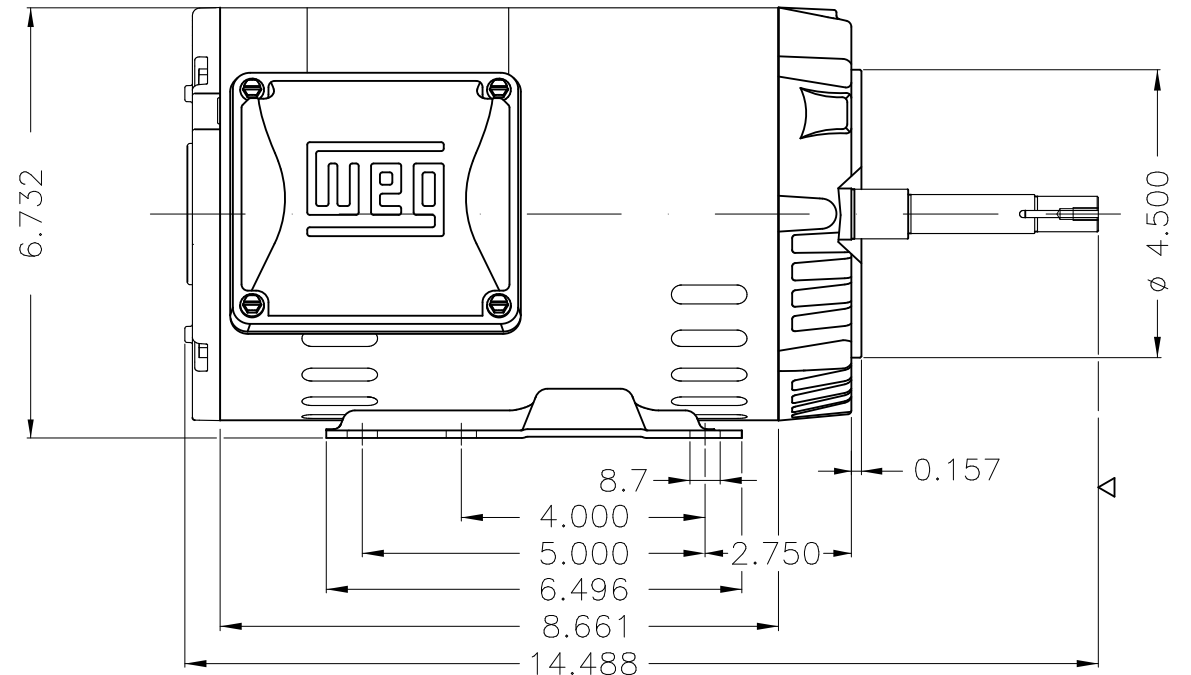
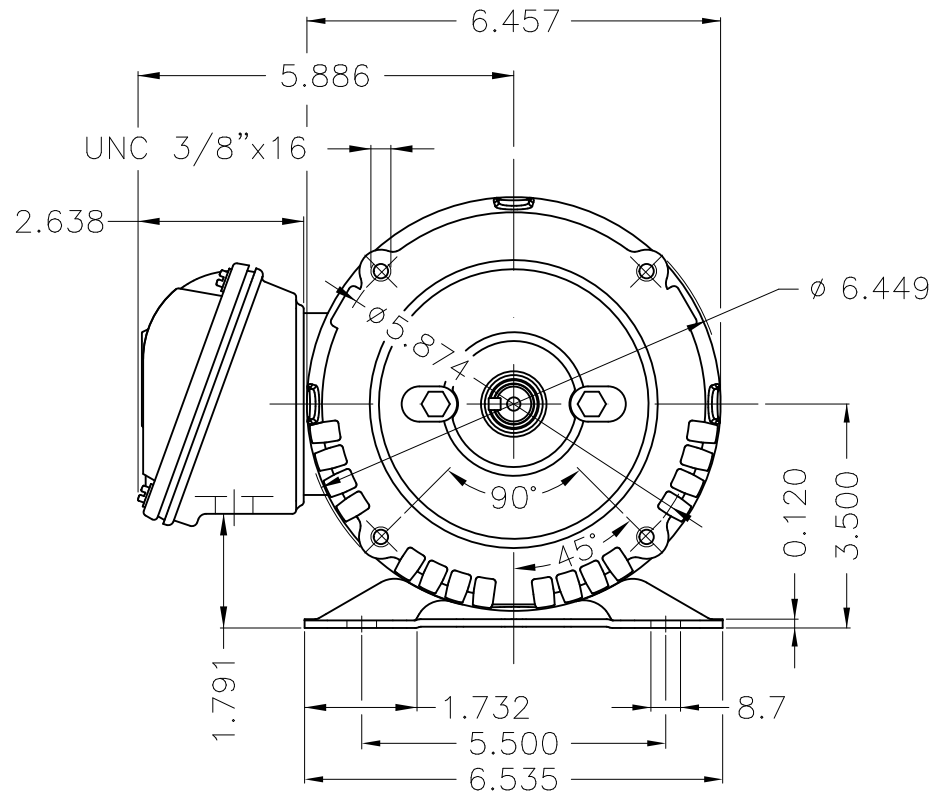

EUNC 3/8"-16 WEG WPR-7309

DE Shaft End

Internal AEGIS ground ring on the DE
 Color Munsell N 1 matte black
 Painting plan 207N
 Mounting F-1/B34R(D)

ECM	LOC	SUMMARY OF MODIFICATIONS	EXECUTED	CHECKED	RELEASED	DATE	VER
EXECUTED	PIRWUSER	THREE PH. MOTOR ROLLED STEEL CLOSE COUPLED PUMP JN TYPE PSE 1/2					
CHECKED		FRAME 143/5JM IP21 ODP					
RELEASED							
REL DT.		WMO Jaragua do Sul	Product Engineering	WDD	SHEET	1 / 1	

3 HP 02 Poles 60 Hz

