

DATA SHEET



Three Phase Induction Motor - Squirrel Cage

Customer :				
Product line	: NEMA Premium Efficiency Three-Phase			
Product code :	14369355			
Catalog # :	00518XT3H184TC			
Frame : 182/4TC Output : 5 HP (3.7 kW) Poles : 4 Frequency : 60 Hz Rated voltage : 575 V Rated current : 5.26 A L. R. Amperes : 37.3 A LRC : 7.1x(Code J) No load current : 2.48 A Rated speed : 1750 rpm Slip : 2.78 % Rated torque : 15.0 ft.lb Locked rotor torque : 229 % Breakdown torque : 300 % Insulation class : F Service factor : 1.15 Moment of inertia (J) : 0.3695 sq.ft.lb Design : B	Locked rotor time : 43s (cold) 24s (hot) Temperature rise : 80 K Duty cycle : Cont.(S1) Ambient temperature : -20°C to +40°C Altitude : 1000 m.a.s.l. Protection degree : IP55 Cooling method : IC411 - TEFC Mounting : F-1 Rotation ¹ : Both (CW and CCW) Noise level ² : 56.0 dB(A) Starting method : Direct On Line Approx. weight ³ : 134 lb			
Output	25% 50% 75% 100%			
Efficiency (%)	85.3 86.5 88.5 89.5			
Power Factor	0.36 0.59 0.71 0.79			
Foundation loads				
Max. traction : 220 lb				
Max. compression : 355 lb				
Bearing type	: <u>Drive end</u> 6307 2RS <u>Non drive end</u> 6206 2RS			
Sealing	: Oil Seal Lip Seal			
Lubrication interval	: - -			
Lubricant amount	: - -			
Lubricant type	: Mobil Polyrex EM			
Notes				
This revision replaces and cancel the previous one, which must be eliminated. (1) Looking the motor from the shaft end. (2) Measured at 1m and with tolerance of +3dB(A). (3) Approximate weight subject to changes after manufacturing process. (4) At 100% of full load.				
These are average values based on tests with sinusoidal power supply, subject to the tolerances stipulated in NEMA MG-1.				
Rev.	Changes Summary	Performed	Checked	Date
Performed by				
Checked by			Page	Revision
Date	12/04/2022		1 / 7	

DATA SHEET

Three Phase Induction Motor - Squirrel Cage



Customer : _____

Thermal protection

ID	Application	Type	Quantity	Sensing Temperature
1	Winding	Thermostat - 2 wires	1 x Phase	155 °C

Rev.	Changes Summary	Performed	Checked	Date
Performed by				
Checked by			Page	Revision
Date	12/04/2022		2 / 7	

TORQUE AND CURRENT VS SPEED CURVE



Three Phase Induction Motor - Squirrel Cage

Customer :

Product line : NEMA Premium Efficiency Three-Phase

Product code : 14369355

Catalog # : 00518XT3H184TC

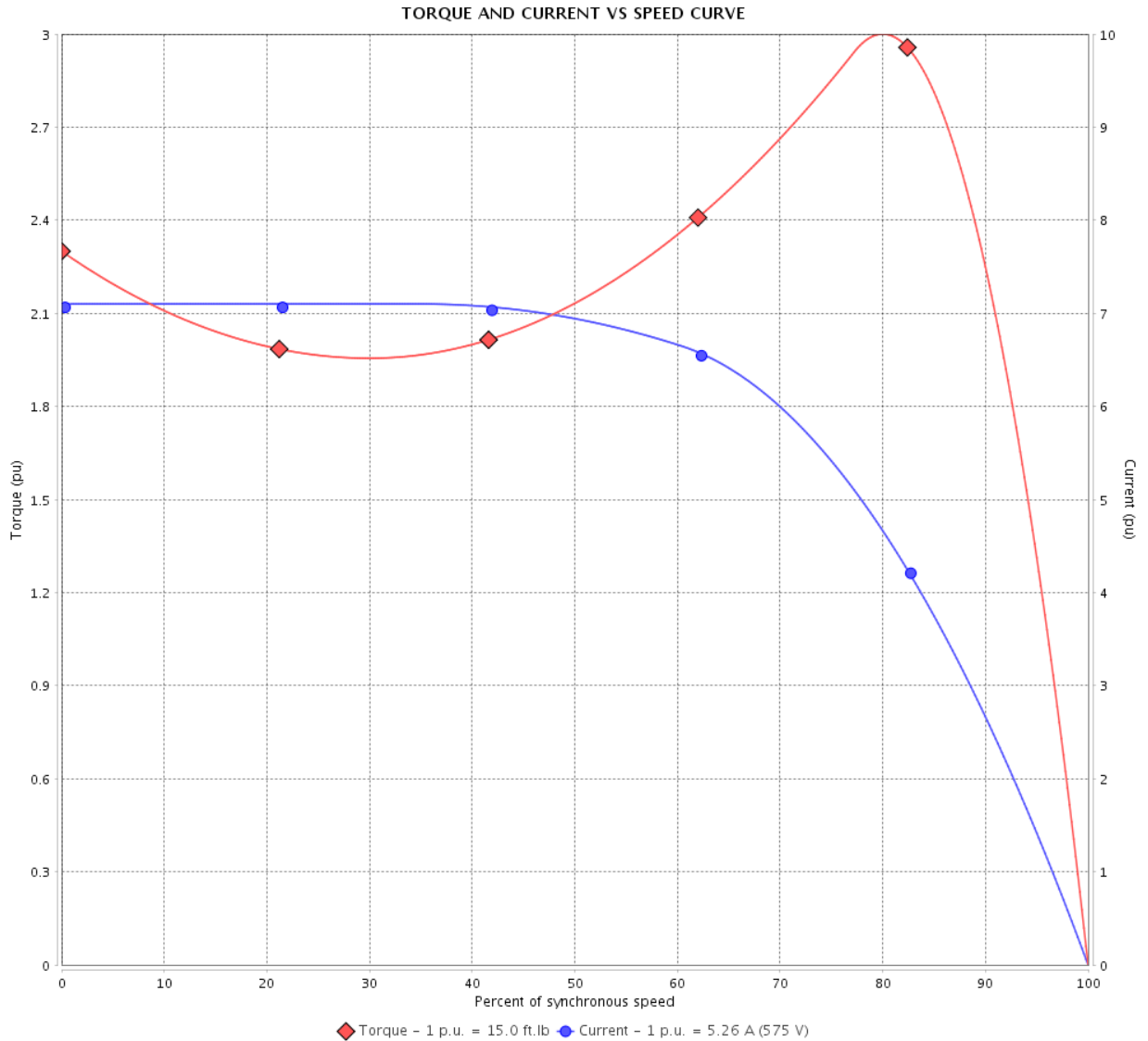

Performance : 575 V 60 Hz 4P

Rated current : 5.26 A
 LRC : 7.1
 Rated torque : 15.0 ft.lb
 Locked rotor torque : 229 %
 Breakdown torque : 300 %
 Rated speed : 1750 rpm

Moment of inertia (J) : 0.3695 sq.ft.lb
 Duty cycle : Cont.(S1)
 Insulation class : F
 Service factor : 1.15
 Temperature rise : 80 K
 Design : B

Locked rotor time : 43s (cold) 24s (hot)

Rev.	Changes Summary	Performed	Checked	Date
Performed by			Page 3 / 7	Revision
Checked by				
Date	12/04/2022			

LOAD PERFORMANCE CURVE

Three Phase Induction Motor - Squirrel Cage



Customer :

Product line : NEMA Premium Efficiency Three-Phase

Product code : 14369355

Catalog # : 00518XT3H184TC

LOAD PERFORMANCE CURVE

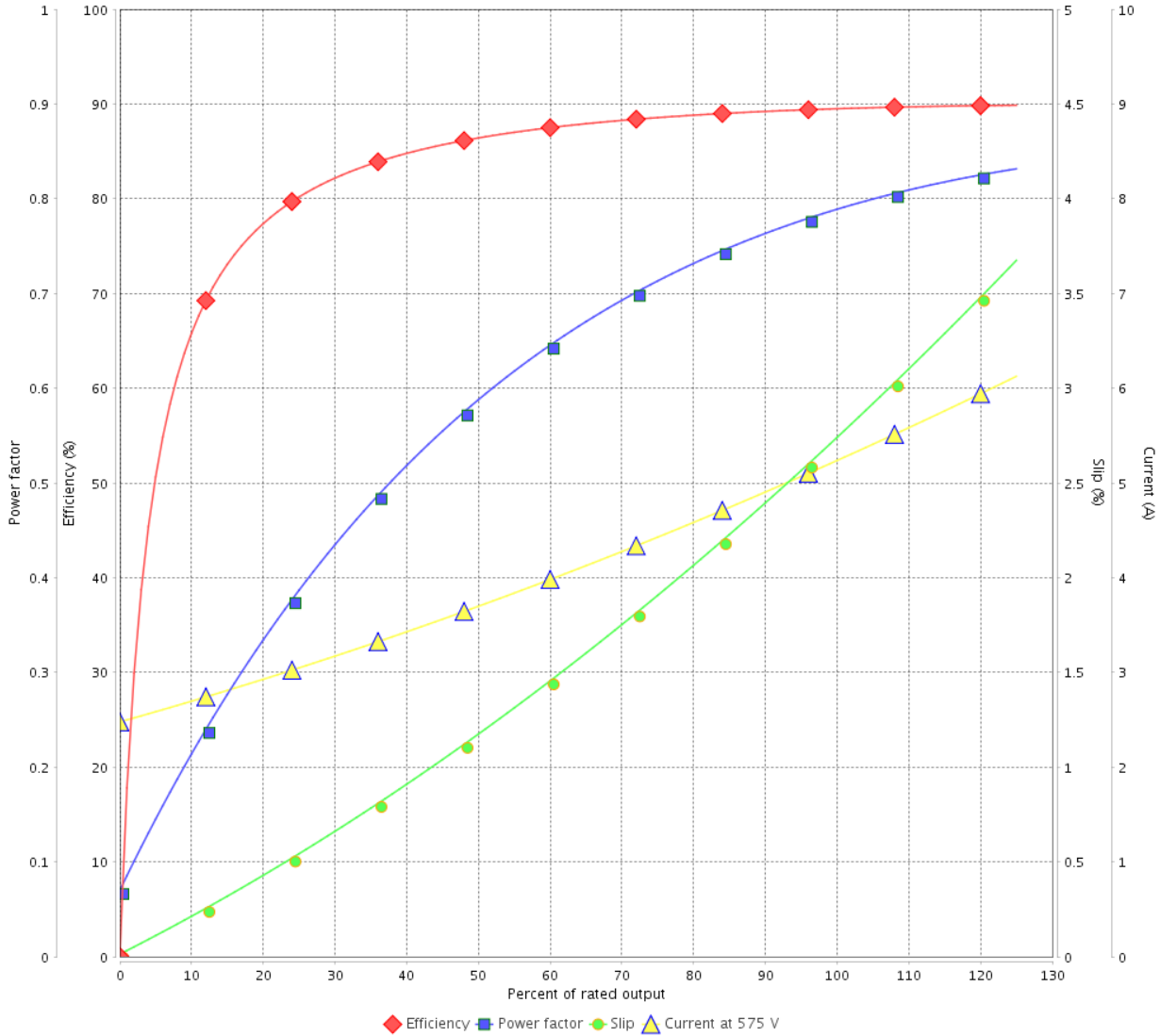

Performance : 575 V 60 Hz 4P

Rated current : 5.26 A
 LRC : 7.1
 Rated torque : 15.0 ft.lb
 Locked rotor torque : 229 %
 Breakdown torque : 300 %
 Rated speed : 1750 rpm

Moment of inertia (J) : 0.3695 sq.ft.lb
 Duty cycle : Cont.(S1)
 Insulation class : F
 Service factor : 1.15
 Temperature rise : 80 K
 Design : B

Rev.	Changes Summary	Performed	Checked	Date
Performed by			Page 4 / 7	Revision
Checked by				
Date	12/04/2022			

THERMAL LIMIT CURVE



Three Phase Induction Motor - Squirrel Cage

Customer :

Product line : NEMA Premium Efficiency Three-Phase

Product code : 14369355

Catalog # : 00518XT3H184TC

Performance : 575 V 60 Hz 4P

Rated current : 5.26 A
 LRC : 7.1
 Rated torque : 15.0 ft.lb
 Locked rotor torque : 229 %
 Breakdown torque : 300 %
 Rated speed : 1750 rpm

Moment of inertia (J) : 0.3695 sq.ft.lb
 Duty cycle : Cont.(S1)
 Insulation class : F
 Service factor : 1.15
 Temperature rise : 80 K
 Design : B

Heating constant

Cooling constant

Rev.	Changes Summary	Performed	Checked	Date
Performed by			Page	Revision
Checked by				
Date	12/04/2022			

THERMAL LIMIT CURVE

Three Phase Induction Motor - Squirrel Cage



Customer : _____

THERMAL LIMIT CURVE

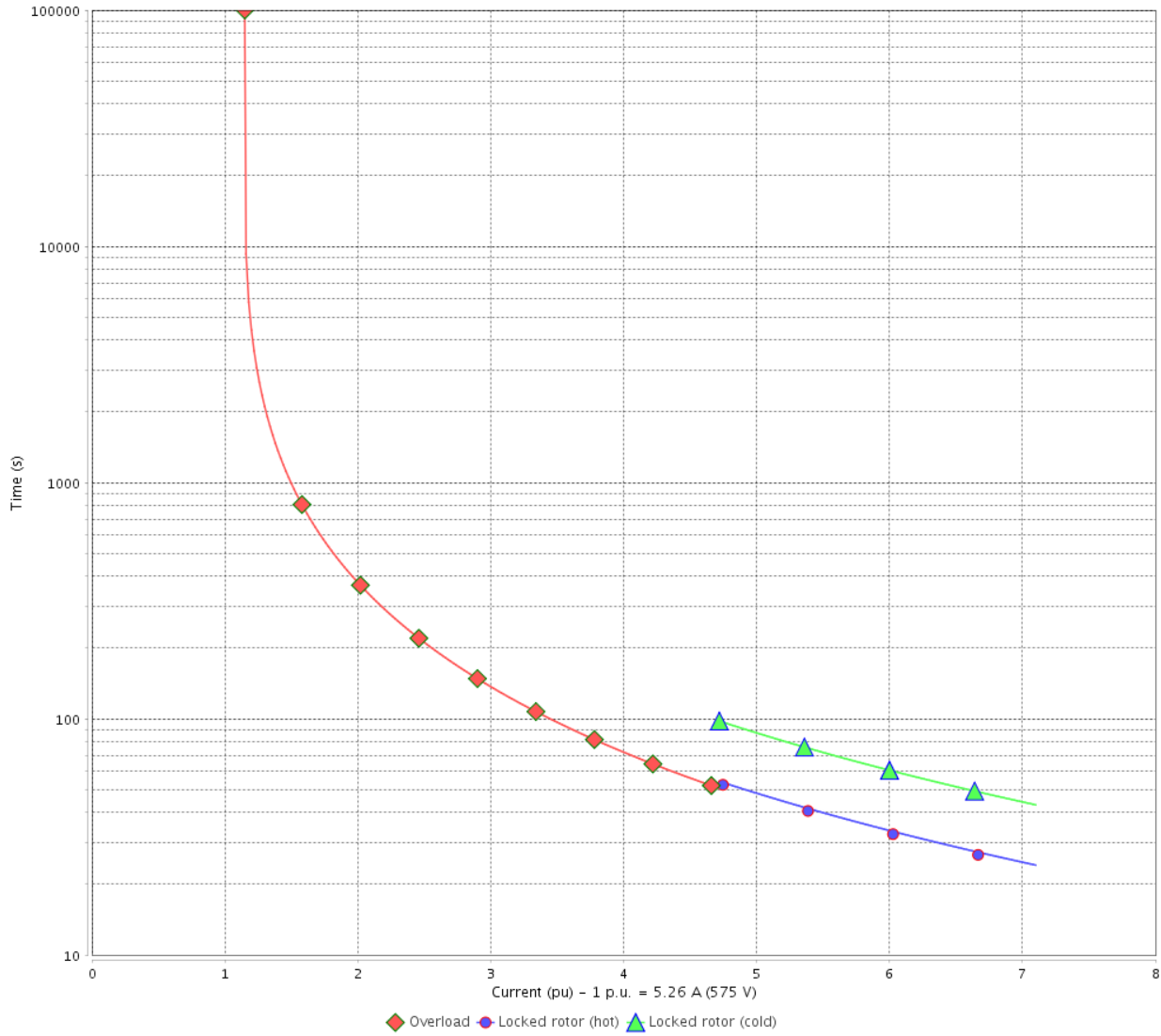

Rev.	Changes Summary	Performed	Checked	Date
Performed by			Page 6 / 7	Revision
Checked by				
Date	12/04/2022			

VFD OPERATION CURVE

Three Phase Induction Motor - Squirrel Cage



Customer :

Product line : NEMA Premium Efficiency Three-Phase

Product code : 14369355

Catalog # : 00518XT3H184TC

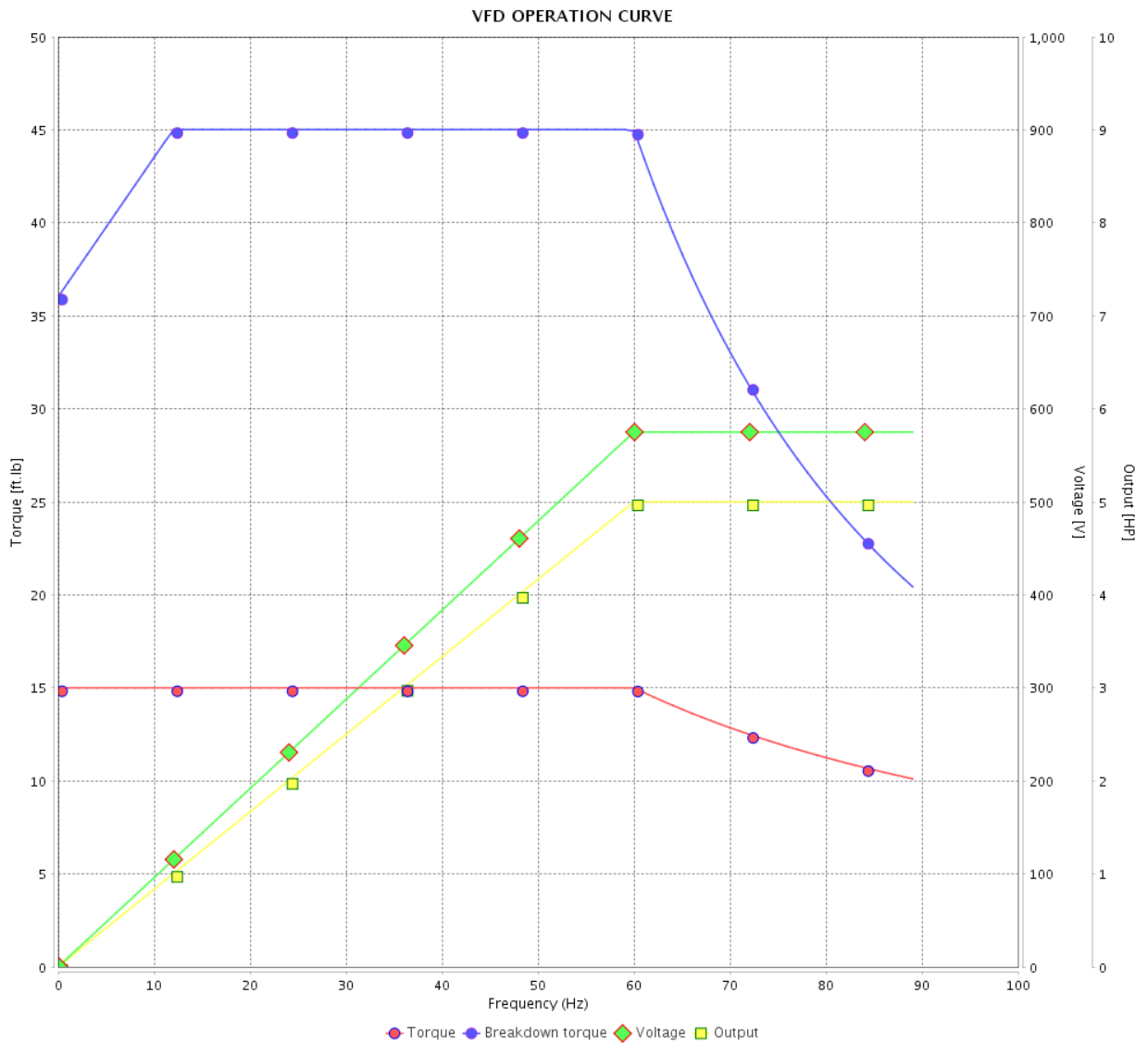

Performance : 575 V 60 Hz 4P

Rated current : 5.26 A
 LRC : 7.1
 Rated torque : 15.0 ft.lb
 Locked rotor torque : 229 %
 Breakdown torque : 300 %
 Rated speed : 1750 rpm

Moment of inertia (J) : 0.3695 sq.ft.lb
 Duty cycle : Cont.(S1)
 Insulation class : F
 Service factor : 1.15
 Temperature rise : 80 K
 Design : B

Rev.	Changes Summary	Performed	Checked	Date
Performed by		Page		Revision
Checked by		7 / 7		
Date		12/04/2022		

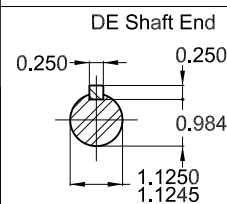
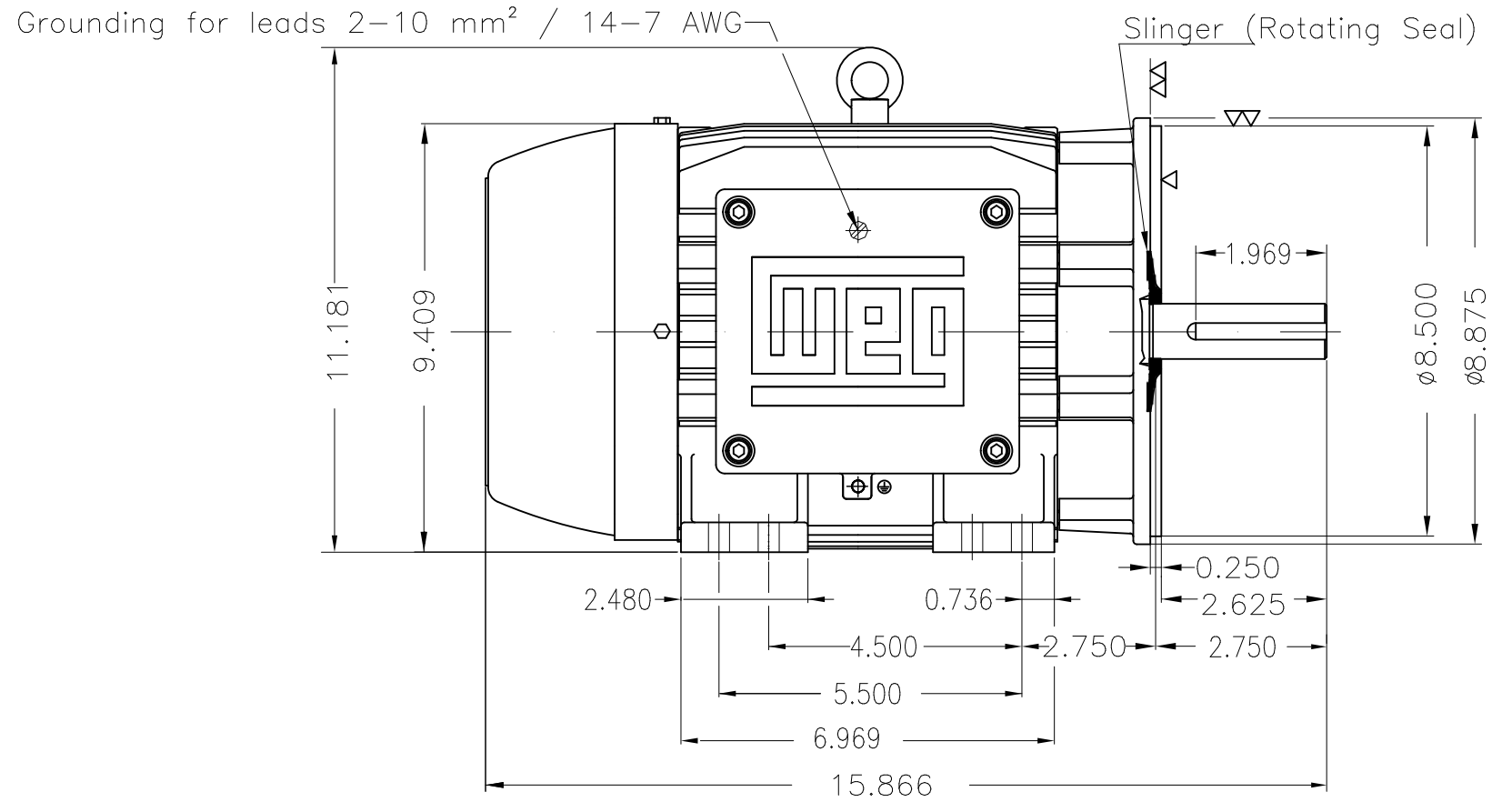
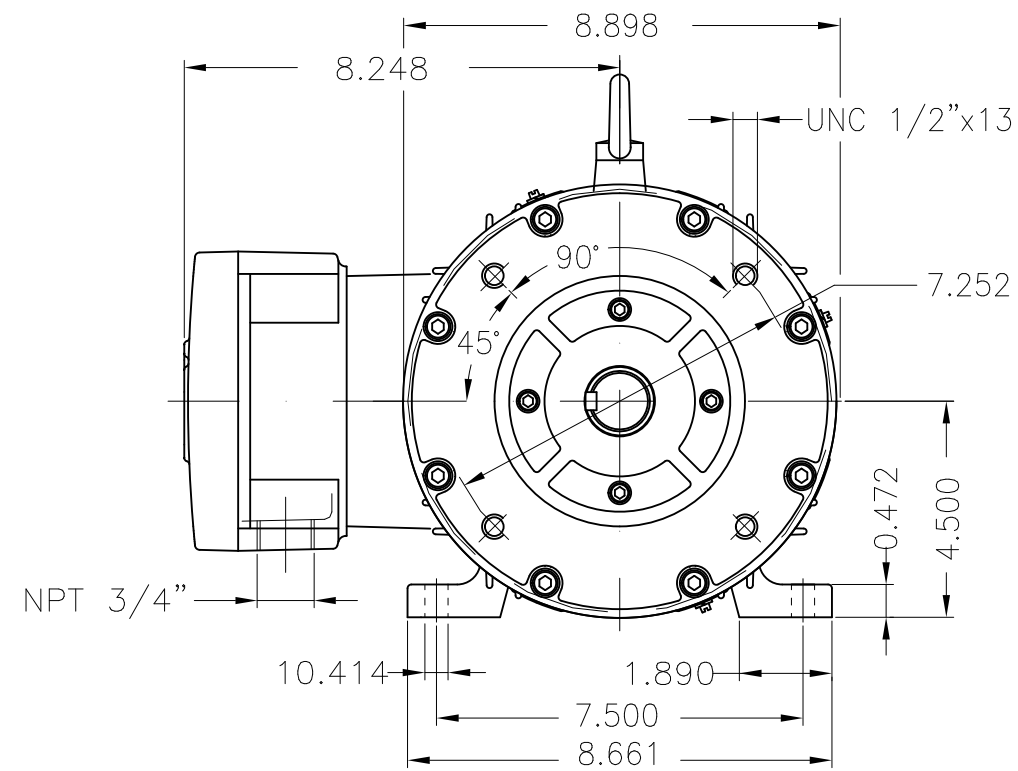

Color RAL 5009
 Painting plan 202P
 Mounting NEMA F-1
 Mounting B34R(D)

5 HP 04 Poles 60 Hz

ECM	LOC	SUMMARY OF MODIFICATIONS	EXECUTED	CHECKED	RELEASED	DATE	VER
EXECUTED	PIRWBUSER	THREE PH. MOTOR EXPLOSION PROOF PREM. EFF.					
CHECKED		FRAME 182/4TC IP55 TEFC					
RELEASED							
REL DT.	WMO	Jaragua do Sul	Product Engineering				

PREVIEW
 WDD



SHEET 1 / 1

MADE IN BRAZIL

W21X NEMA
Premium

14369355



LISTED

CC029A

Inverter Duty Motor
Severe Duty

MODEL 00518XT3H184TC

PH 3 | FR 182/4TC

HP(kW) 5.0(3.7)

HZ 60

IP55

V 575

A 5.26

RPM 1750

NEMA NOM EFF 89.5%

PF 0.79

SFA 6.05

DES B

INS CL F Δ T 80 K | SF 1.15

ENCL TEFC

DUTY CONT.

CODE J

ALT 1000

m.a.s.l.

AMB 40°C

AMB 55°C SF1.0

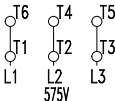

→ 6307-2RS MOBIL POLYREX EM

→ 6206-2RS

134 Lbs



TEMP CODE T3C

CSA/UL: Class I - Div. 1 - Groups C and D

CSA: Class II - Div. 1 - Groups F and G

CSA: Class I - Zone 1 - IIB

EXPLOSION PROOF MOTOR

FOR USE ON VPWM VFD 1000:1VT, 20:1CT, 1.0SF, T3C, AMB 40°C.