

DATA SHEET

Three Phase Induction Motor - Squirrel Cage



Customer :				
Product line		: NEMA Premium Efficiency Three-Phase	Product code :	11584390
			Catalog # :	01509ST3QIE286T-W22
Frame	: 284/6T	Cooling method	: IC411 - TEFC	
Insulation class	: F	Mounting	: F-1	
Duty cycle	: Cont.(S1)	Rotation ¹	: Both (CW and CCW)	
Ambient temperature	: -20°C to +40°C	Starting method	: Direct On Line	
Altitude	: 1000 m.a.s.l.	Approx. weight ²	: 421 lb	
Protection degree	: IP55	Moment of inertia (J)	: 8.18 sq.ft.lb	
Design	: B			
Output [HP]	15	15	15	15
Poles	8	8	8	8
Frequency [Hz]	60	50	50	50
Rated voltage [V]	460	380	400	415
Rated current [A]	19.6	23.6	22.7	22.1
L. R. Amperes [A]	108	101	109	113
LRC [A]	5.5x(Code G)	4.3x(Code D)	4.8x(Code F)	5.1x(Code F)
No load current [A]	9.80	9.70	10.5	11.1
Rated speed [RPM]	880	720	725	730
Slip [%]	2.22	4.00	3.33	2.67
Rated torque [ft.lb]	89.5	109	109	108
Locked rotor torque [%]	200	150	170	190
Breakdown torque [%]	229	180	200	220
Service factor	1.25	1.00	1.00	1.15
Temperature rise	80 K	105 K	105 K	105 K
Locked rotor time	45s (cold) 25s (hot)	32s (cold) 18s (hot)	32s (cold) 18s (hot)	32s (cold) 18s (hot)
Noise level ²	54.0 dB(A)	52.0 dB(A)	52.0 dB(A)	52.0 dB(A)
Efficiency (%)	25%			
	50%	85.5	88.0	88.0
	75%	90.0	88.5	88.5
	100%	90.2	88.6	88.6
Power Factor	25%			
	50%	0.62	0.68	0.64
	75%	0.72	0.76	0.74
	100%	0.78	0.80	0.79
Bearing type	: <u>Drive end</u> 6311 C3 <u>Non drive end</u> 6211 C3	Foundation loads		
Sealing	: Inpro/Seal Inpro/Seal	Max. traction	: 825 lb	
Lubrication interval	: 20000 h 20000 h	Max. compression	: 1246 lb	
Lubricant amount	: 18 g 11 g			
Lubricant type	: Mobil Polyrex EM			
Notes				
This revision replaces and cancel the previous one, which must be eliminated. (1) Looking the motor from the shaft end. (2) Measured at 1m and with tolerance of +3dB(A). (3) Approximate weight subject to changes after manufacturing process. (4) At 100% of full load.		These are average values based on tests with sinusoidal power supply, subject to the tolerances stipulated in NEMA MG-1.		
Rev.	Changes Summary		Performed	Checked
				Date
Performed by				
Checked by			Page	Revision
Date	13/04/2022		1 / 21	

TORQUE AND CURRENT VS SPEED CURVE

Three Phase Induction Motor - Squirrel Cage



Customer :

Product line : NEMA Premium Efficiency Three-Phase

Product code : 11584390

Catalog # : 01509ST3QIE286T-W22

TORQUE AND CURRENT VS SPEED CURVE

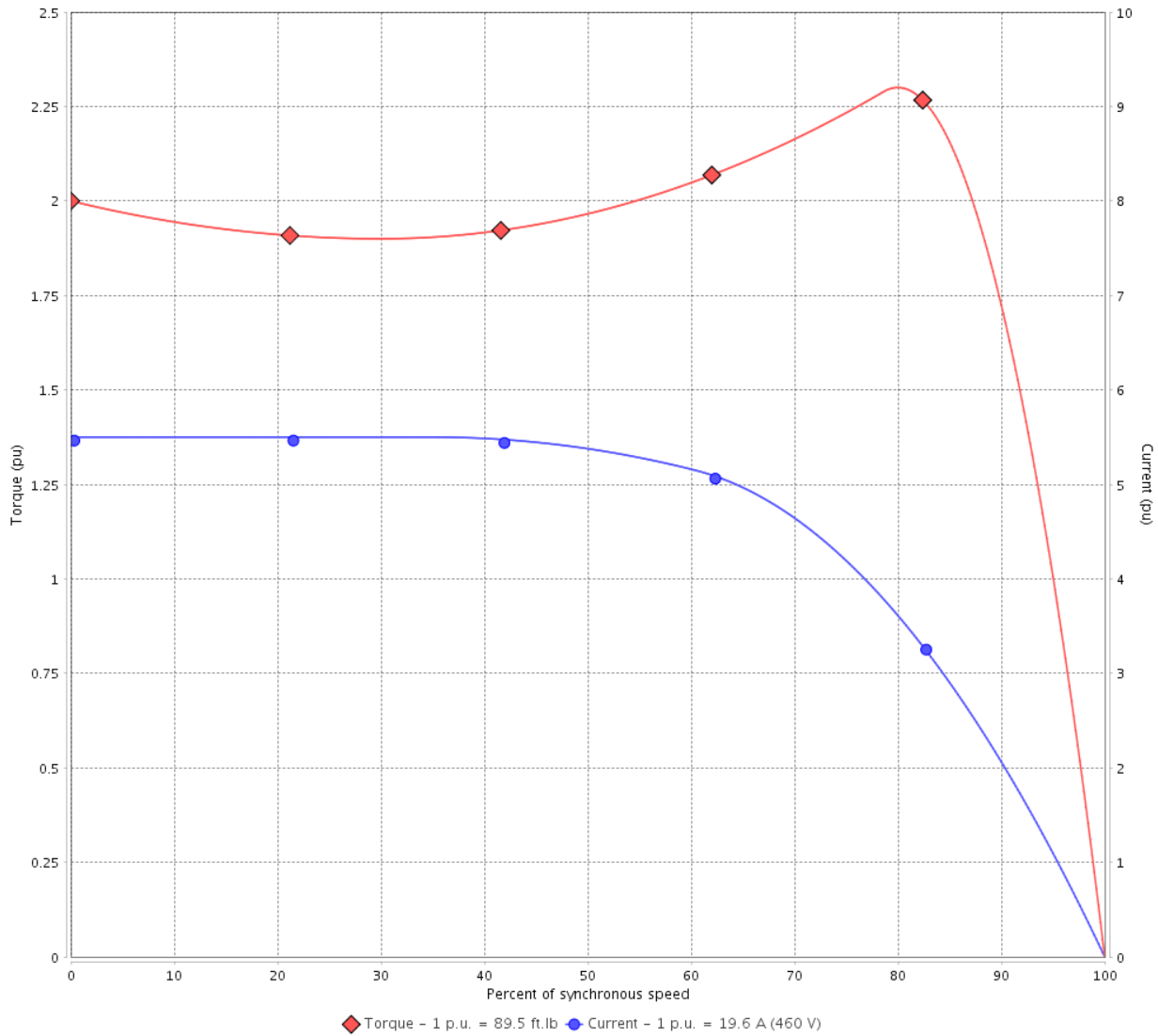

Performance : 460 V 60 Hz 8P

Rated current	: 19.6 A	Moment of inertia (J)	: 8.18 sq.ft.lb
LRC	: 5.5	Duty cycle	: Cont.(S1)
Rated torque	: 89.5 ft.lb	Insulation class	: F
Locked rotor torque	: 200 %	Service factor	: 1.25
Breakdown torque	: 229 %	Temperature rise	: 80 K
Rated speed	: 880 rpm	Design	: B

Locked rotor time : 45s (cold) 25s (hot)

Rev.	Changes Summary	Performed	Checked	Date
Performed by			Page 2 / 21	Revision
Checked by				
Date	13/04/2022			

TORQUE AND CURRENT VS SPEED CURVE



Three Phase Induction Motor - Squirrel Cage

Customer :

Product line : NEMA Premium Efficiency Three-Phase

Product code : 11584390

Catalog # : 01509ST3QIE286T-W22

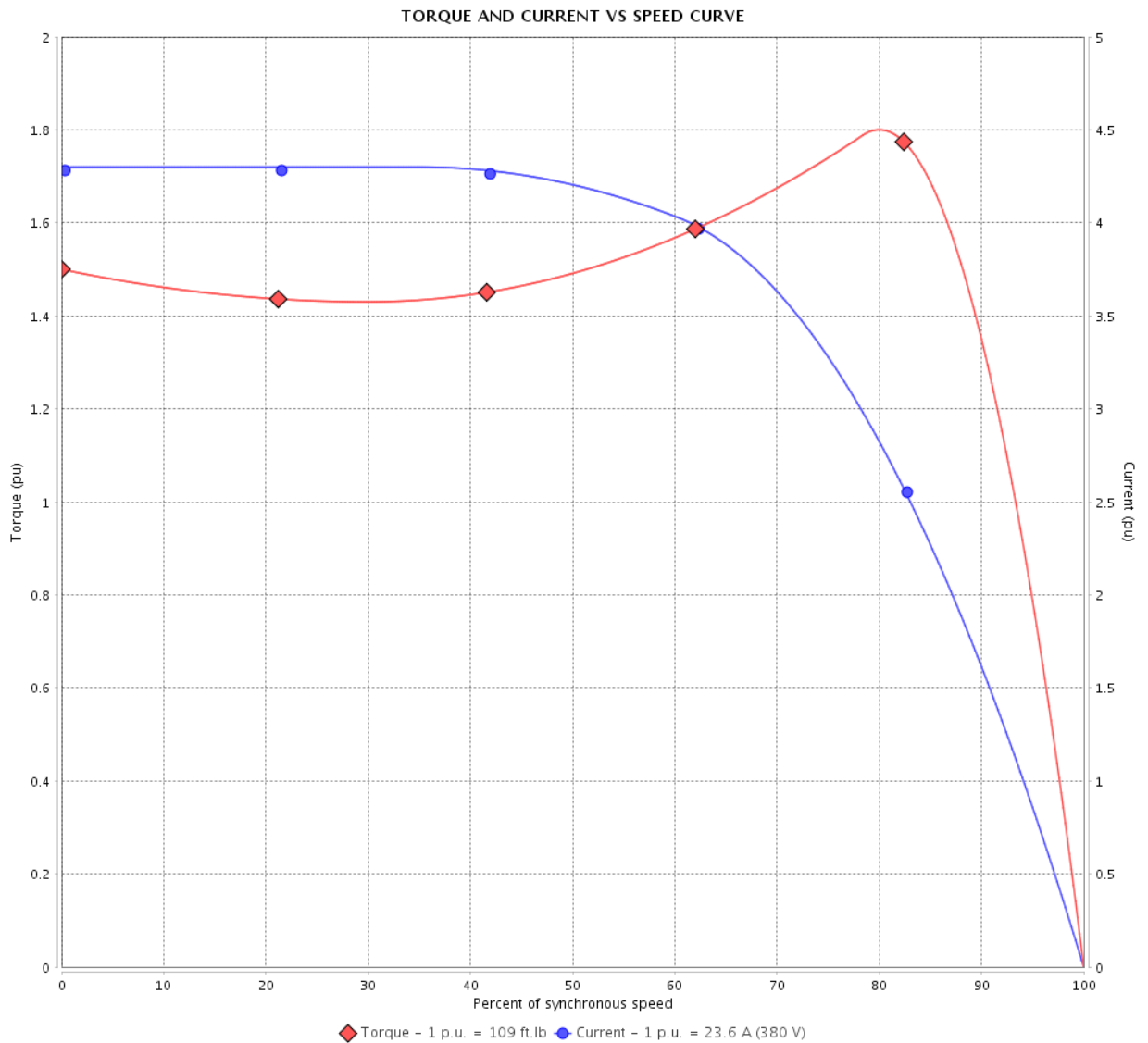

Performance : 380 V 50 Hz 8P IE3

Rated current	: 23.6 A	Moment of inertia (J)	: 8.18 sq.ft.lb
LRC	: 4.3	Duty cycle	: Cont.(S1)
Rated torque	: 109 ft.lb	Insulation class	: F
Locked rotor torque	: 150 %	Service factor	: 1.00
Breakdown torque	: 180 %	Temperature rise	: 105 K
Rated speed	: 720 rpm	Design	: B

Locked rotor time : 32s (cold) 18s (hot)

Rev.	Changes Summary	Performed	Checked	Date
Performed by			Page 3 / 21	Revision
Checked by				
Date	13/04/2022			

TORQUE AND CURRENT VS SPEED CURVE

Three Phase Induction Motor - Squirrel Cage



Customer :

Product line : NEMA Premium Efficiency Three-Phase

Product code : 11584390

Catalog # : 01509ST3QIE286T-W22

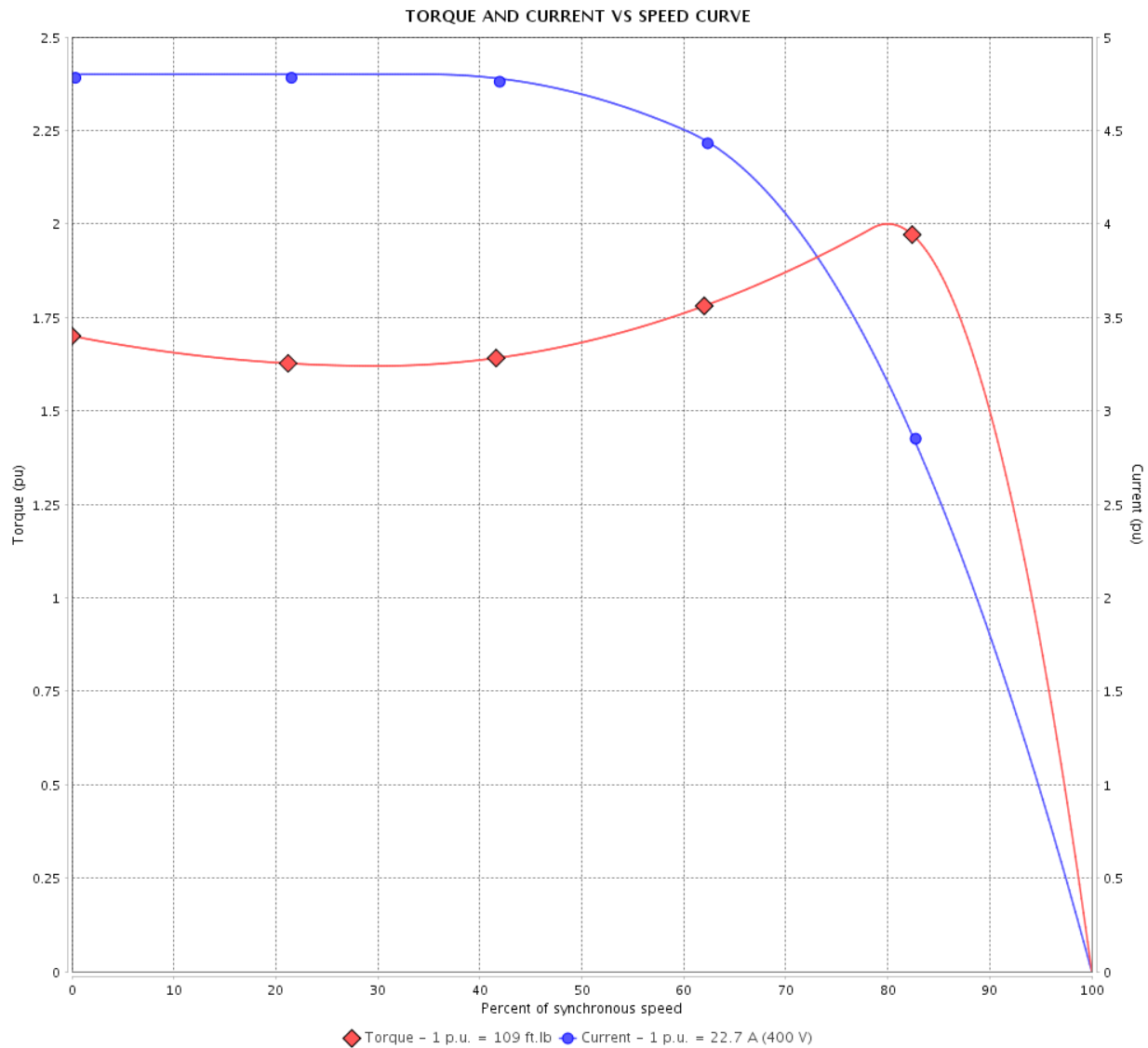

Performance : 400 V 50 Hz 8P IE3

Rated current	: 22.7 A	Moment of inertia (J)	: 8.18 sq.ft.lb
LRC	: 4.8	Duty cycle	: Cont.(S1)
Rated torque	: 109 ft.lb	Insulation class	: F
Locked rotor torque	: 170 %	Service factor	: 1.00
Breakdown torque	: 200 %	Temperature rise	: 105 K
Rated speed	: 725 rpm	Design	: B

Locked rotor time : 32s (cold) 18s (hot)

Rev.	Changes Summary	Performed	Checked	Date
Performed by			Page 4 / 21	Revision
Checked by				
Date	13/04/2022			

TORQUE AND CURRENT VS SPEED CURVE



Three Phase Induction Motor - Squirrel Cage

Customer :

Product line : NEMA Premium Efficiency Three-Phase

Product code : 11584390

Catalog # : 01509ST3QIE286T-W22

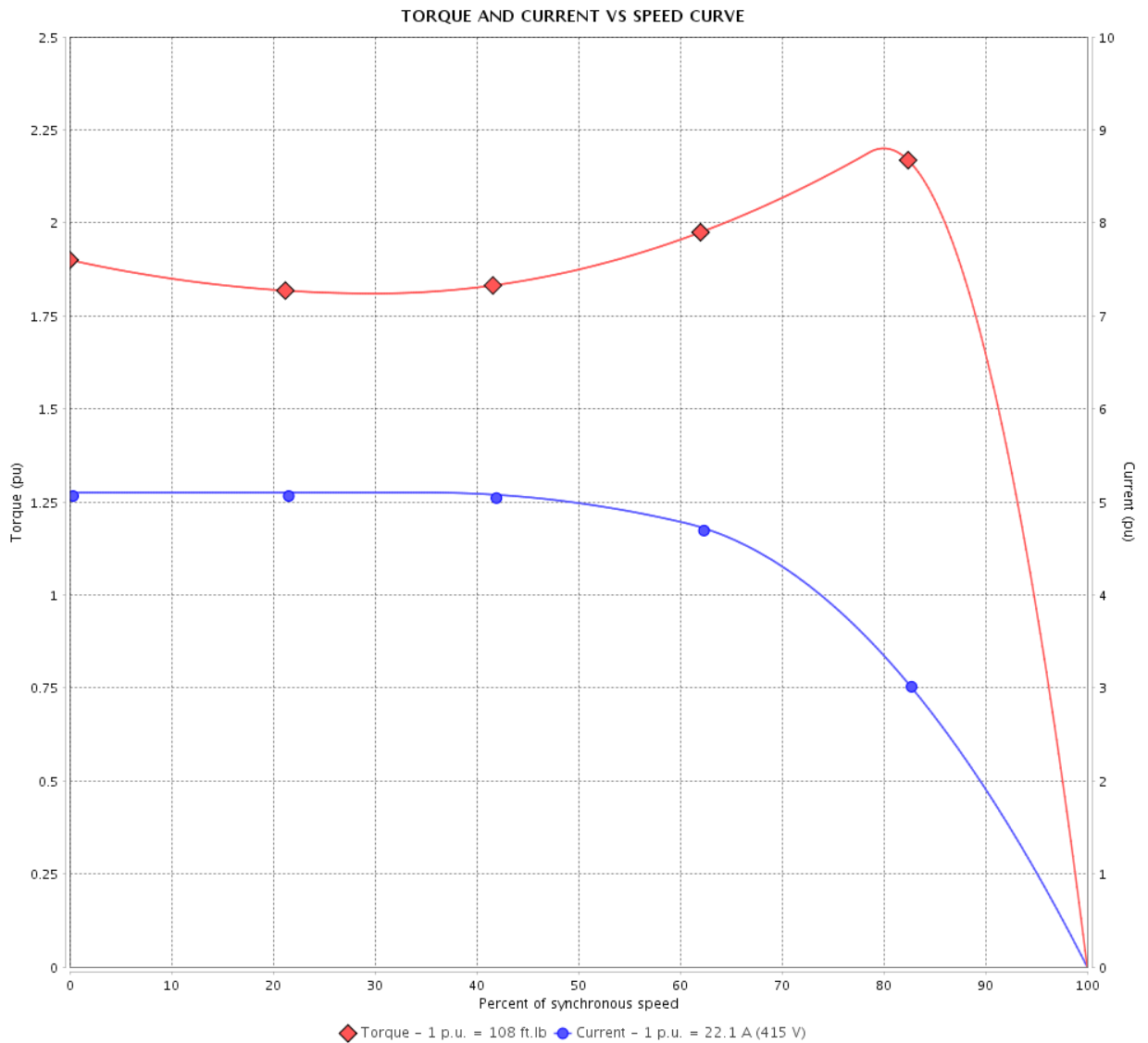

Performance : 415 V 50 Hz 8P IE3

Rated current	: 22.1 A	Moment of inertia (J)	: 8.18 sq.ft.lb
LRC	: 5.1	Duty cycle	: Cont.(S1)
Rated torque	: 108 ft.lb	Insulation class	: F
Locked rotor torque	: 190 %	Service factor	: 1.15
Breakdown torque	: 220 %	Temperature rise	: 105 K
Rated speed	: 730 rpm	Design	: B

Locked rotor time : 32s (cold) 18s (hot)

Rev.	Changes Summary	Performed	Checked	Date
Performed by			Page 5 / 21	Revision
Checked by				
Date	13/04/2022			

LOAD PERFORMANCE CURVE

Three Phase Induction Motor - Squirrel Cage



Customer :

Product line : NEMA Premium Efficiency Three-Phase

Product code : 11584390

Catalog # : 01509ST3QIE286T-W22

LOAD PERFORMANCE CURVE

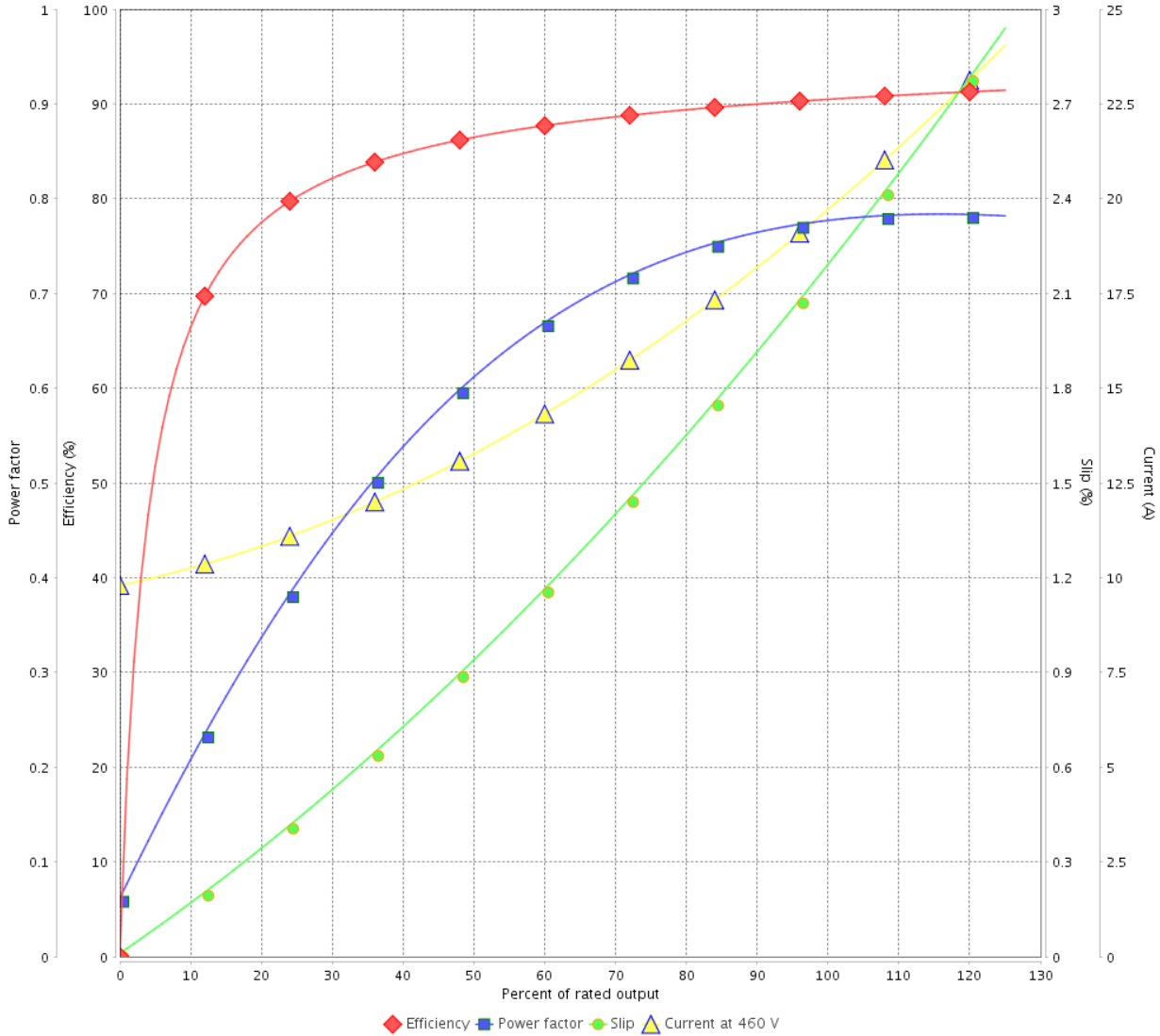

Performance : 460 V 60 Hz 8P

Rated current : 19.6 A
 LRC : 5.5
 Rated torque : 89.5 ft.lb
 Locked rotor torque : 200 %
 Breakdown torque : 229 %
 Rated speed : 880 rpm

Moment of inertia (J) : 8.18 sq.ft.lb
 Duty cycle : Cont.(S1)
 Insulation class : F
 Service factor : 1.25
 Temperature rise : 80 K
 Design : B

Rev.	Changes Summary	Performed	Checked	Date
Performed by			Page 6 / 21	Revision
Checked by				
Date	13/04/2022			

LOAD PERFORMANCE CURVE

Three Phase Induction Motor - Squirrel Cage



Customer : _____

Product line : NEMA Premium Efficiency Three-Phase

Product code : 11584390

Catalog # : 01509ST3QIE286T-W22

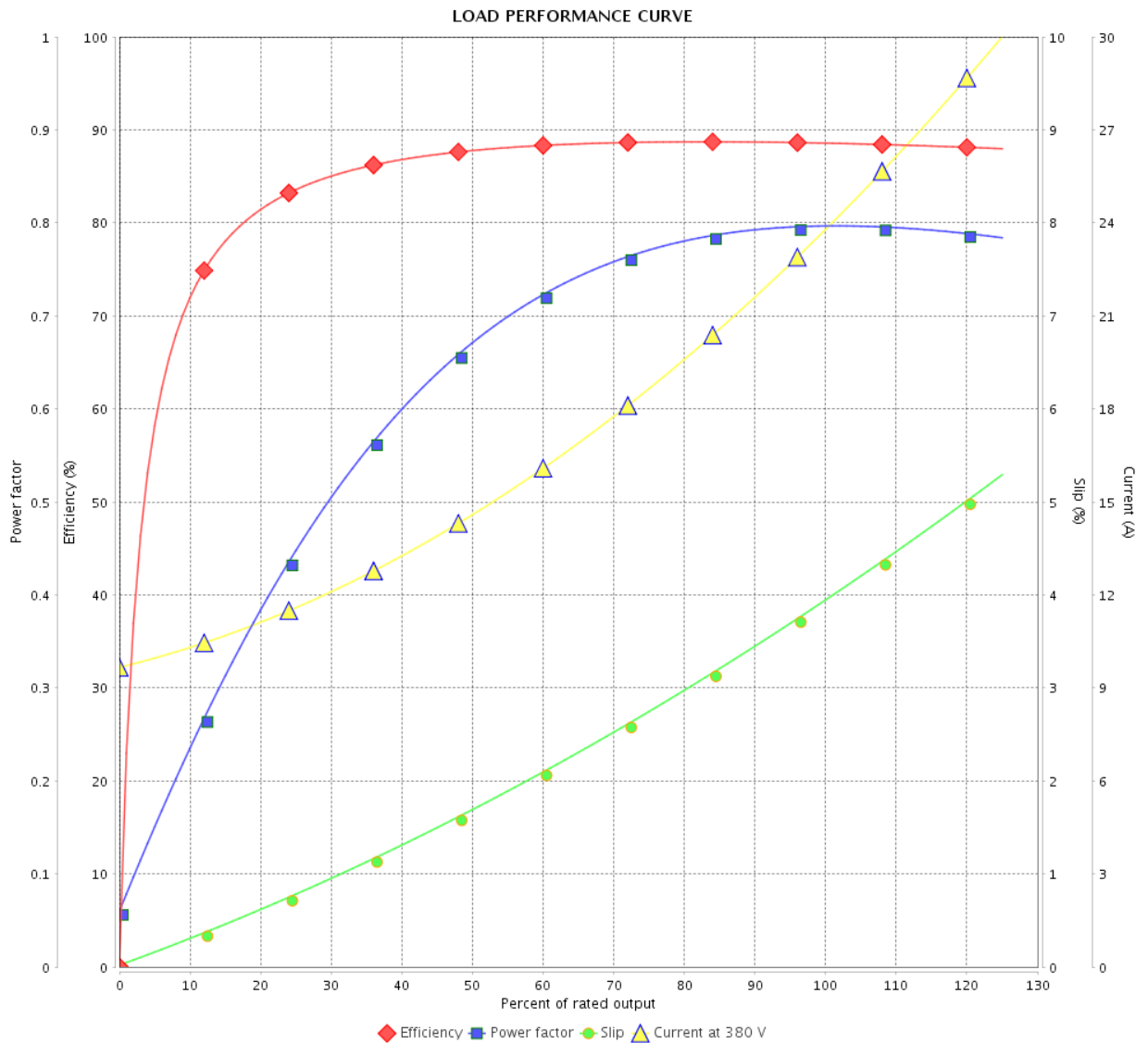

Performance : 380 V 50 Hz 8P IE3

Rated current : 23.6 A
 LRC : 4.3
 Rated torque : 109 ft.lb
 Locked rotor torque : 150 %
 Breakdown torque : 180 %
 Rated speed : 720 rpm

Moment of inertia (J) : 8.18 sq.ft.lb
 Duty cycle : Cont.(S1)
 Insulation class : F
 Service factor : 1.00
 Temperature rise : 105 K
 Design : B

Rev.	Changes Summary	Performed	Checked	Date
Performed by			Page	Revision
Checked by				
Date				
			7 / 21	

LOAD PERFORMANCE CURVE

Three Phase Induction Motor - Squirrel Cage



Customer :

Product line : NEMA Premium Efficiency Three-Phase

Product code : 11584390

Catalog # : 01509ST3QIE286T-W22

LOAD PERFORMANCE CURVE

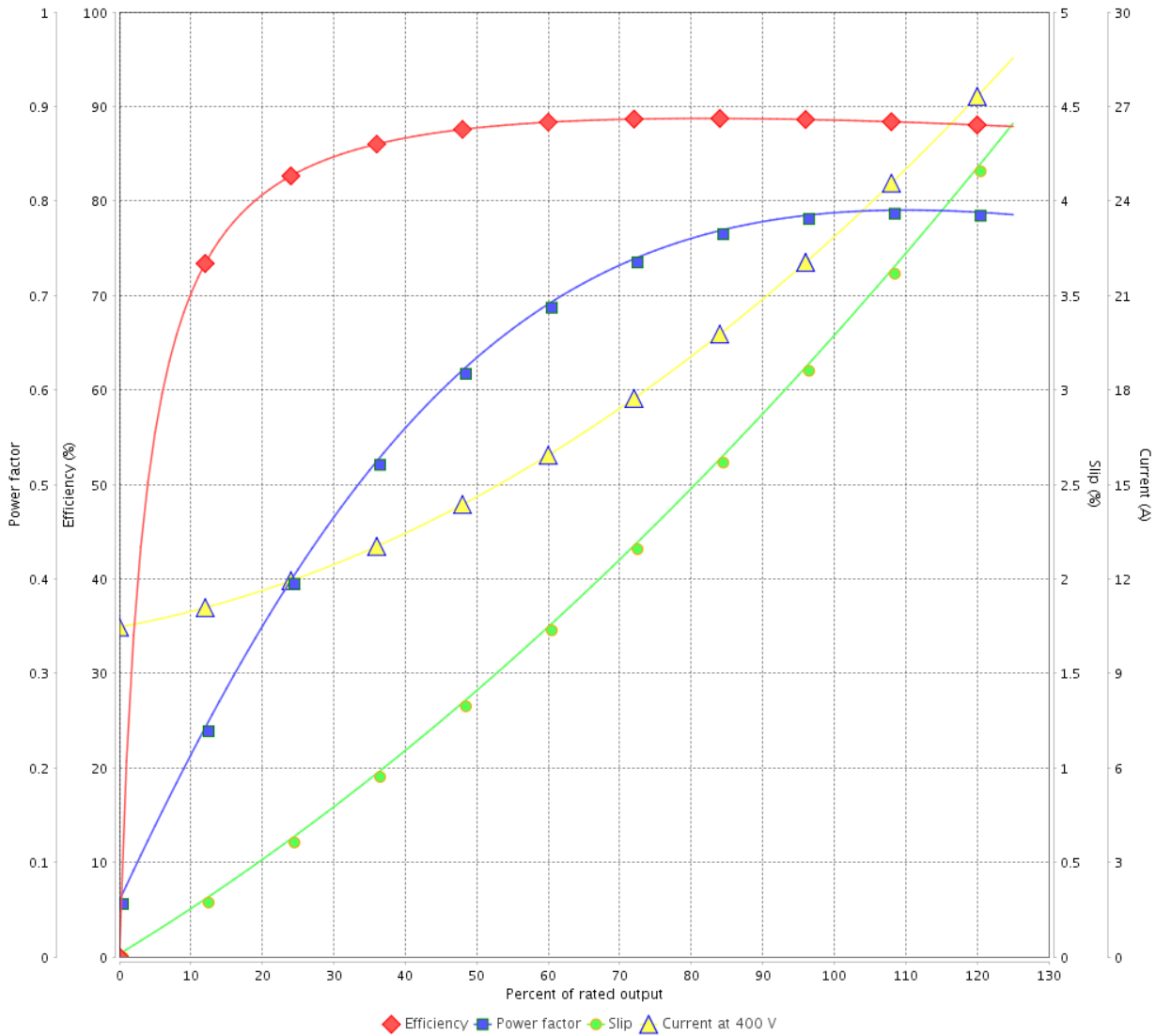

Performance : 400 V 50 Hz 8P IE3

Rated current : 22.7 A
 LRC : 4.8
 Rated torque : 109 ft.lb
 Locked rotor torque : 170 %
 Breakdown torque : 200 %
 Rated speed : 725 rpm

Moment of inertia (J) : 8.18 sq.ft.lb
 Duty cycle : Cont.(S1)
 Insulation class : F
 Service factor : 1.00
 Temperature rise : 105 K
 Design : B

Rev.	Changes Summary	Performed	Checked	Date
Performed by		Page		Revision
Checked by		8 / 21		
Date	13/04/2022			

LOAD PERFORMANCE CURVE

Three Phase Induction Motor - Squirrel Cage



Customer : _____

Product line : NEMA Premium Efficiency Three-Phase

Product code : 11584390

Catalog # : 01509ST3QIE286T-W22

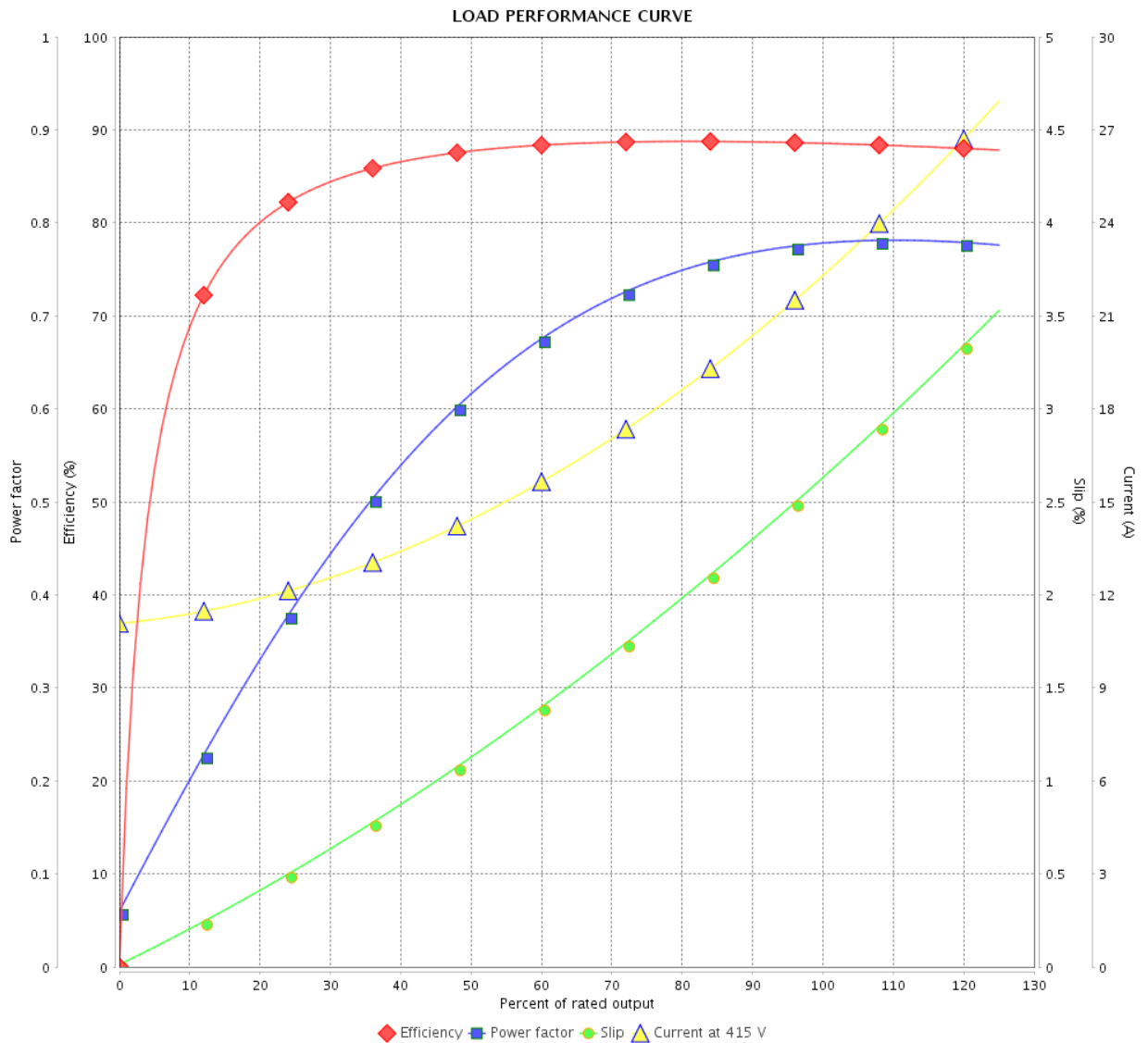

Performance : 415 V 50 Hz 8P IE3

Rated current : 22.1 A
 LRC : 5.1
 Rated torque : 108 ft.lb
 Locked rotor torque : 190 %
 Breakdown torque : 220 %
 Rated speed : 730 rpm

Moment of inertia (J) : 8.18 sq.ft.lb
 Duty cycle : Cont.(S1)
 Insulation class : F
 Service factor : 1.15
 Temperature rise : 105 K
 Design : B

Rev.	Changes Summary	Performed	Checked	Date
Performed by		Page		Revision
Checked by		9 / 21		
Date		13/04/2022		

THERMAL LIMIT CURVE

Three Phase Induction Motor - Squirrel Cage



Customer :

Product line : NEMA Premium Efficiency Three-Phase

Product code : 11584390

Catalog # : 01509ST3QIE286T-W22

Performance : 460 V 60 Hz 8P

Rated current	: 19.6 A	Moment of inertia (J)	: 8.18 sq.ft.lb
LRC	: 5.5	Duty cycle	: Cont.(S1)
Rated torque	: 89.5 ft.lb	Insulation class	: F
Locked rotor torque	: 200 %	Service factor	: 1.25
Breakdown torque	: 229 %	Temperature rise	: 80 K
Rated speed	: 880 rpm	Design	: B

Heating constant

Cooling constant

Rev.	Changes Summary	Performed	Checked	Date
Performed by				
Checked by			Page	Revision
Date	13/04/2022		10 / 21	

THERMAL LIMIT CURVE

Three Phase Induction Motor - Squirrel Cage



Customer : _____

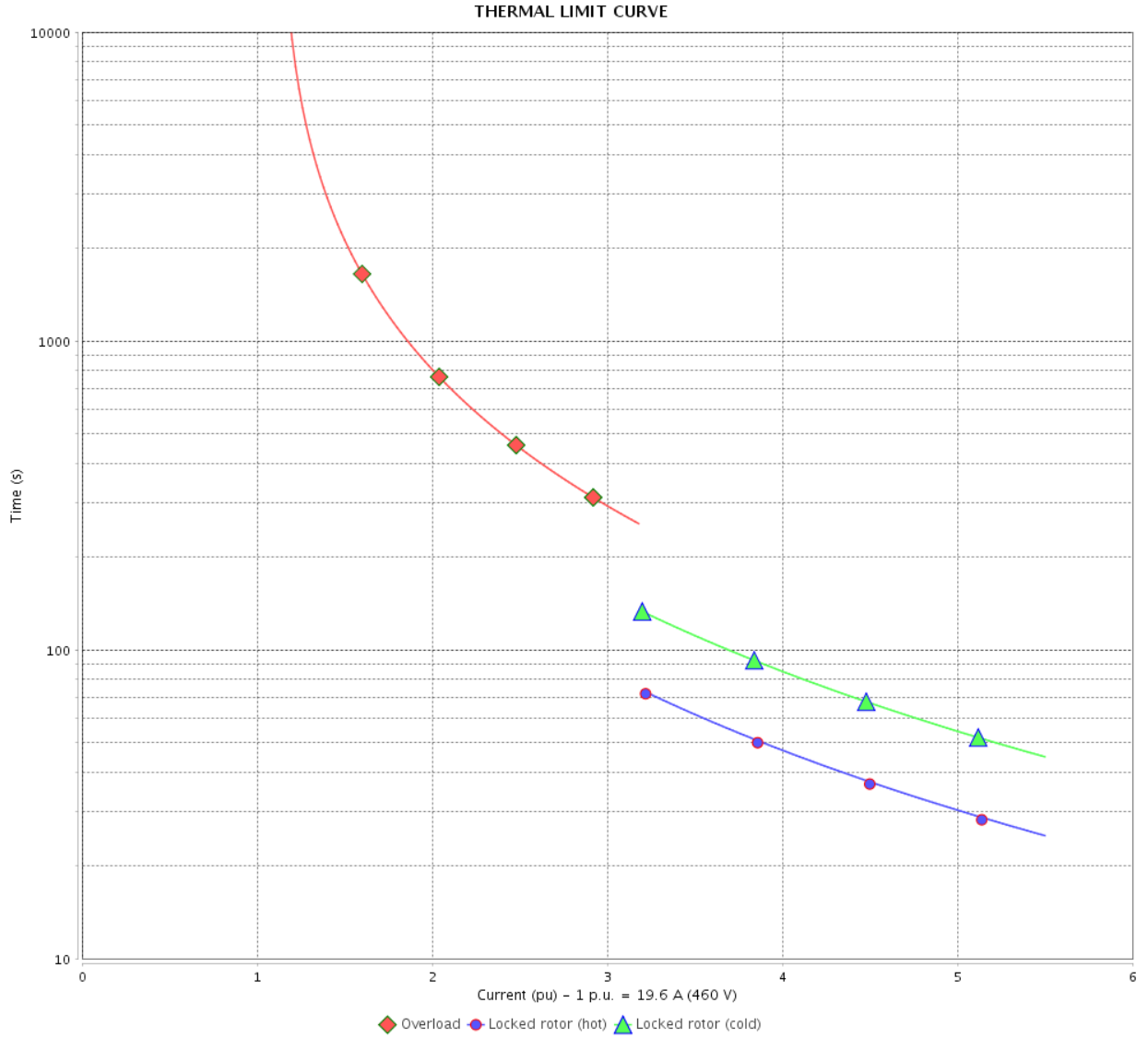

Rev.	Changes Summary	Performed	Checked	Date
Performed by		Page		Revision
Checked by		11 / 21		
Date		13/04/2022		

THERMAL LIMIT CURVE



Three Phase Induction Motor - Squirrel Cage

Customer :

Product line : NEMA Premium Efficiency Three-Phase

Product code : 11584390

Catalog # : 01509ST3QIE286T-W22

Performance : 380 V 50 Hz 8P IE3

Rated current	: 23.6 A	Moment of inertia (J)	: 8.18 sq.ft.lb
LRC	: 4.3	Duty cycle	: Cont.(S1)
Rated torque	: 109 ft.lb	Insulation class	: F
Locked rotor torque	: 150 %	Service factor	: 1.00
Breakdown torque	: 180 %	Temperature rise	: 105 K
Rated speed	: 720 rpm	Design	: B

Heating constant

Cooling constant

Rev.	Changes Summary	Performed	Checked	Date
Performed by				
Checked by			Page	Revision
Date	13/04/2022		12 / 21	

THERMAL LIMIT CURVE

Three Phase Induction Motor - Squirrel Cage



Customer : _____

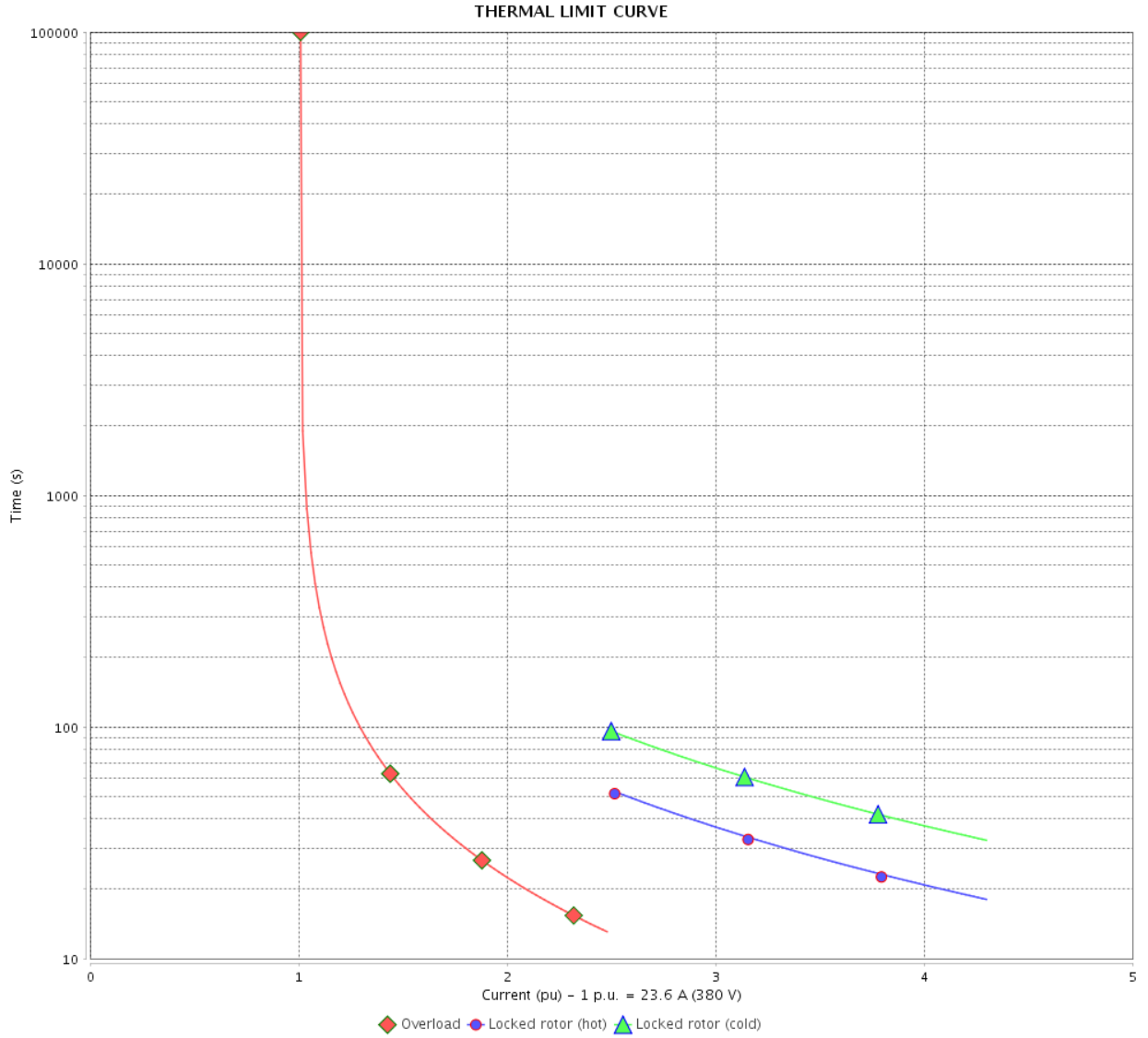

Rev.	Changes Summary	Performed	Checked	Date
Performed by				
Checked by				
Date				
		Page	Revision	
		13 / 21		

THERMAL LIMIT CURVE



Three Phase Induction Motor - Squirrel Cage

Customer :

Product line : NEMA Premium Efficiency Three-Phase

Product code : 11584390

Catalog # : 01509ST3QIE286T-W22

Performance : 400 V 50 Hz 8P IE3

Rated current	: 22.7 A	Moment of inertia (J)	: 8.18 sq.ft.lb
LRC	: 4.8	Duty cycle	: Cont.(S1)
Rated torque	: 109 ft.lb	Insulation class	: F
Locked rotor torque	: 170 %	Service factor	: 1.00
Breakdown torque	: 200 %	Temperature rise	: 105 K
Rated speed	: 725 rpm	Design	: B

Heating constant

Cooling constant

Rev.	Changes Summary	Performed	Checked	Date
Performed by				
Checked by			Page	Revision
Date	13/04/2022		14 / 21	

THERMAL LIMIT CURVE

Three Phase Induction Motor - Squirrel Cage



Customer : _____

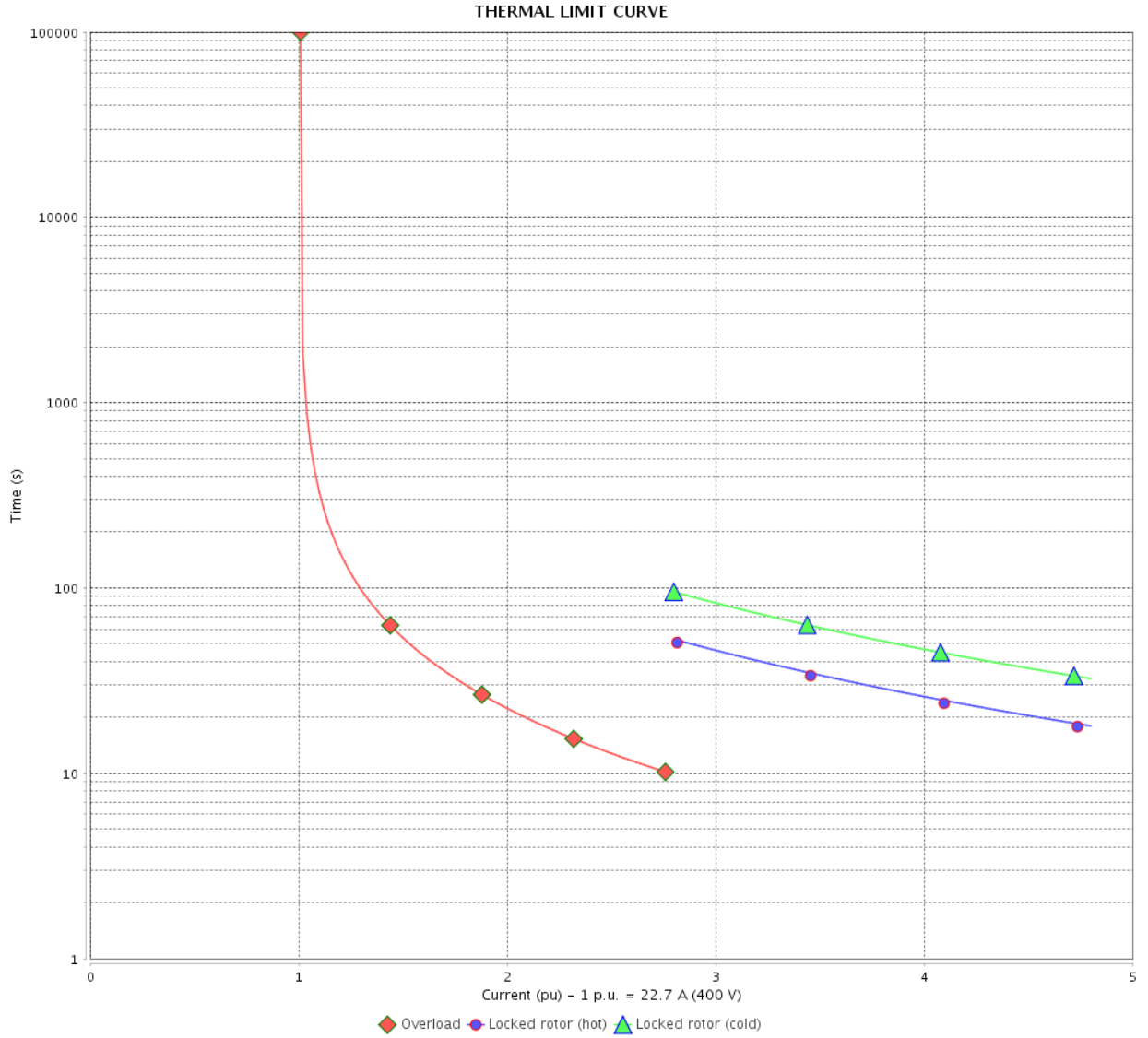

Rev.	Changes Summary	Performed	Checked	Date
Performed by		Page		Revision
Checked by		15 / 21		
Date		13/04/2022		

THERMAL LIMIT CURVE



Three Phase Induction Motor - Squirrel Cage

Customer :

Product line : NEMA Premium Efficiency Three-Phase
Product code : 11584390
Catalog # : 01509ST3QIE286T-W22

Performance : 415 V 50 Hz 8P IE3

Rated current	: 22.1 A	Moment of inertia (J)	: 8.18 sq.ft.lb
LRC	: 5.1	Duty cycle	: Cont.(S1)
Rated torque	: 108 ft.lb	Insulation class	: F
Locked rotor torque	: 190 %	Service factor	: 1.15
Breakdown torque	: 220 %	Temperature rise	: 105 K
Rated speed	: 730 rpm	Design	: B

Heating constant

Cooling constant

Rev.	Changes Summary	Performed	Checked	Date
Performed by				
Checked by			Page	Revision
Date	13/04/2022		16 / 21	

THERMAL LIMIT CURVE

Three Phase Induction Motor - Squirrel Cage



Customer : _____

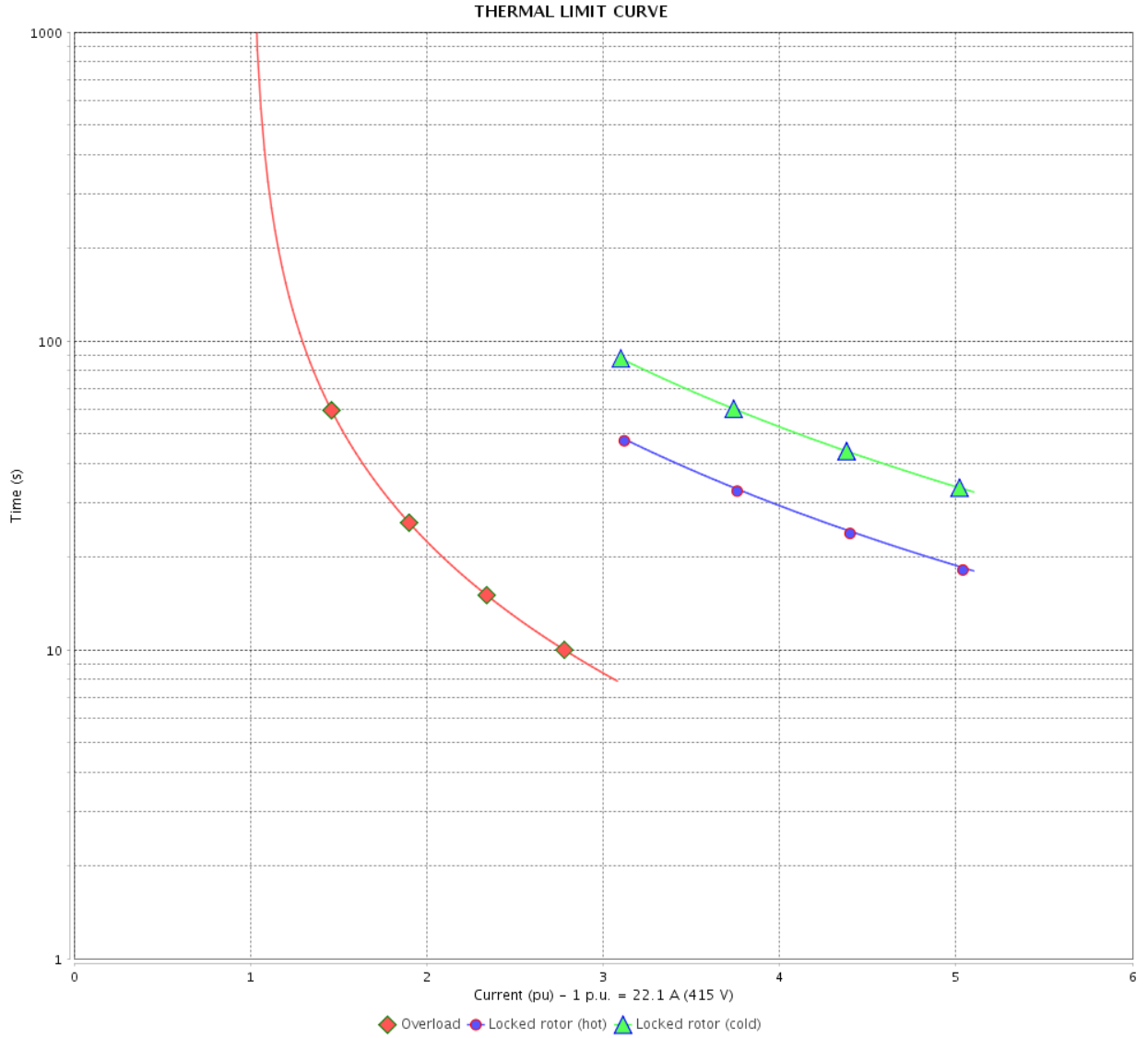

Rev.	Changes Summary	Performed	Checked	Date
Performed by		Page		Revision
Checked by		17 / 21		
Date		13/04/2022		

VFD OPERATION CURVE

Three Phase Induction Motor - Squirrel Cage



Customer :

Product line : NEMA Premium Efficiency Three-Phase

Product code : 11584390

Catalog # : 01509ST3QIE286T-W22

VFD OPERATION CURVE

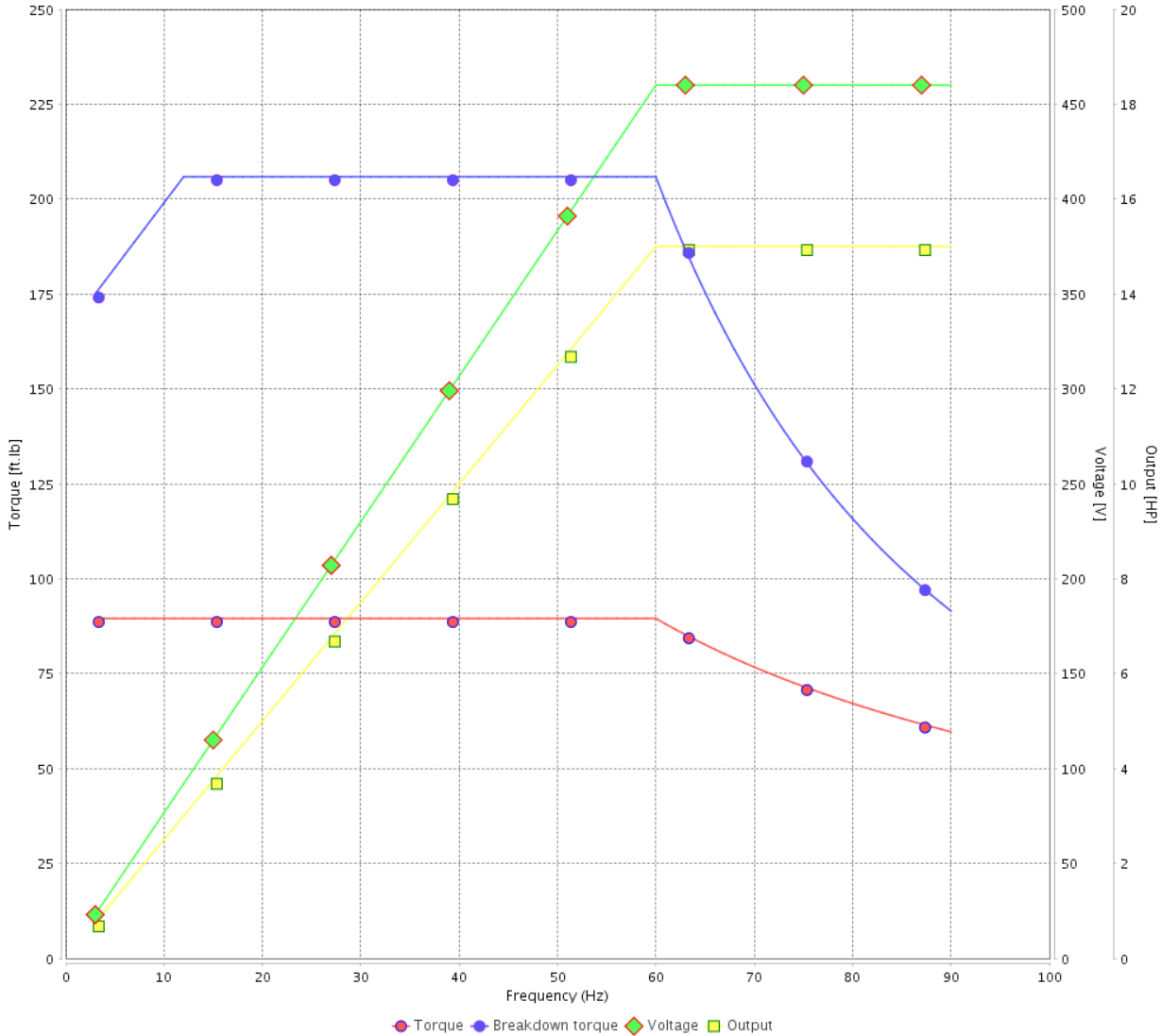

Performance : 460 V 60 Hz 8P

Rated current : 19.6 A
 LRC : 5.5
 Rated torque : 89.5 ft.lb
 Locked rotor torque : 200 %
 Breakdown torque : 229 %
 Rated speed : 880 rpm

Moment of inertia (J) : 8.18 sq.ft.lb
 Duty cycle : Cont.(S1)
 Insulation class : F
 Service factor : 1.25
 Temperature rise : 80 K
 Design : B

Rev.	Changes Summary	Performed	Checked	Date
Performed by			Page	Revision
Checked by				
Date				

VFD OPERATION CURVE

Three Phase Induction Motor - Squirrel Cage



Customer :

Product line : NEMA Premium Efficiency Three-Phase

Product code : 11584390

Catalog # : 01509ST3QIE286T-W22

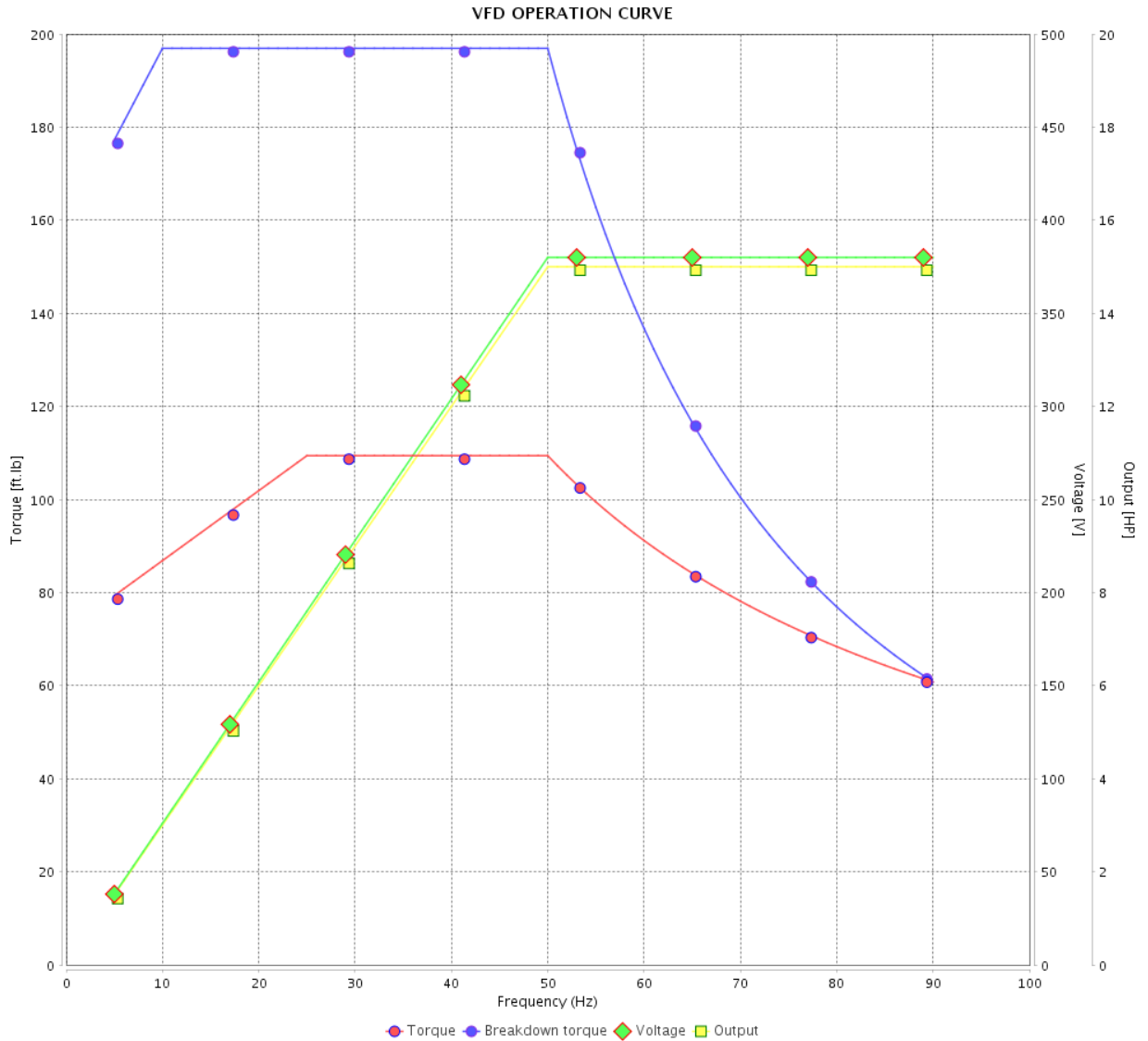

Performance : 380 V 50 Hz 8P IE3

Rated current : 23.6 A
 LRC : 4.3
 Rated torque : 109 ft.lb
 Locked rotor torque : 150 %
 Breakdown torque : 180 %
 Rated speed : 720 rpm

Moment of inertia (J) : 8.18 sq.ft.lb
 Duty cycle : Cont.(S1)
 Insulation class : F
 Service factor : 1.00
 Temperature rise : 105 K
 Design : B

Rev.	Changes Summary	Performed	Checked	Date
Performed by			Page 19 / 21	Revision
Checked by				
Date	13/04/2022			

VFD OPERATION CURVE

Three Phase Induction Motor - Squirrel Cage



Customer :

Product line : NEMA Premium Efficiency Three-Phase

Product code : 11584390

Catalog # : 01509ST3QIE286T-W22

VFD OPERATION CURVE

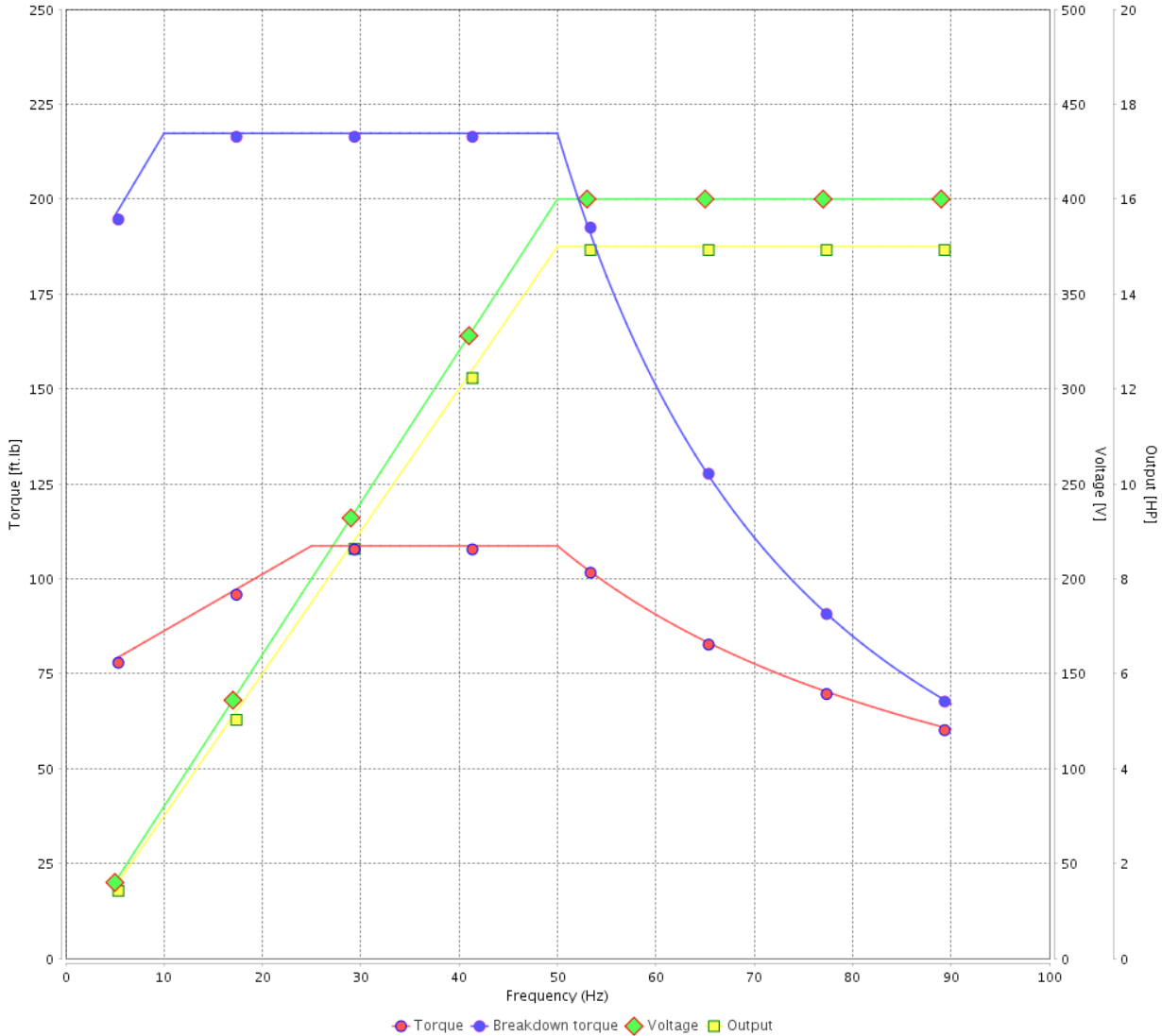

Performance : 400 V 50 Hz 8P IE3

Rated current	: 22.7 A	Moment of inertia (J)	: 8.18 sq.ft.lb
LRC	: 4.8	Duty cycle	: Cont.(S1)
Rated torque	: 109 ft.lb	Insulation class	: F
Locked rotor torque	: 170 %	Service factor	: 1.00
Breakdown torque	: 200 %	Temperature rise	: 105 K
Rated speed	: 725 rpm	Design	: B

Rev.	Changes Summary	Performed	Checked	Date
Performed by			Page 20 / 21	Revision
Checked by				
Date	13/04/2022			

VFD OPERATION CURVE

Three Phase Induction Motor - Squirrel Cage



Customer : _____

Product line : NEMA Premium Efficiency Three-Phase

Product code : 11584390

Catalog # : 01509ST3QIE286T-W22

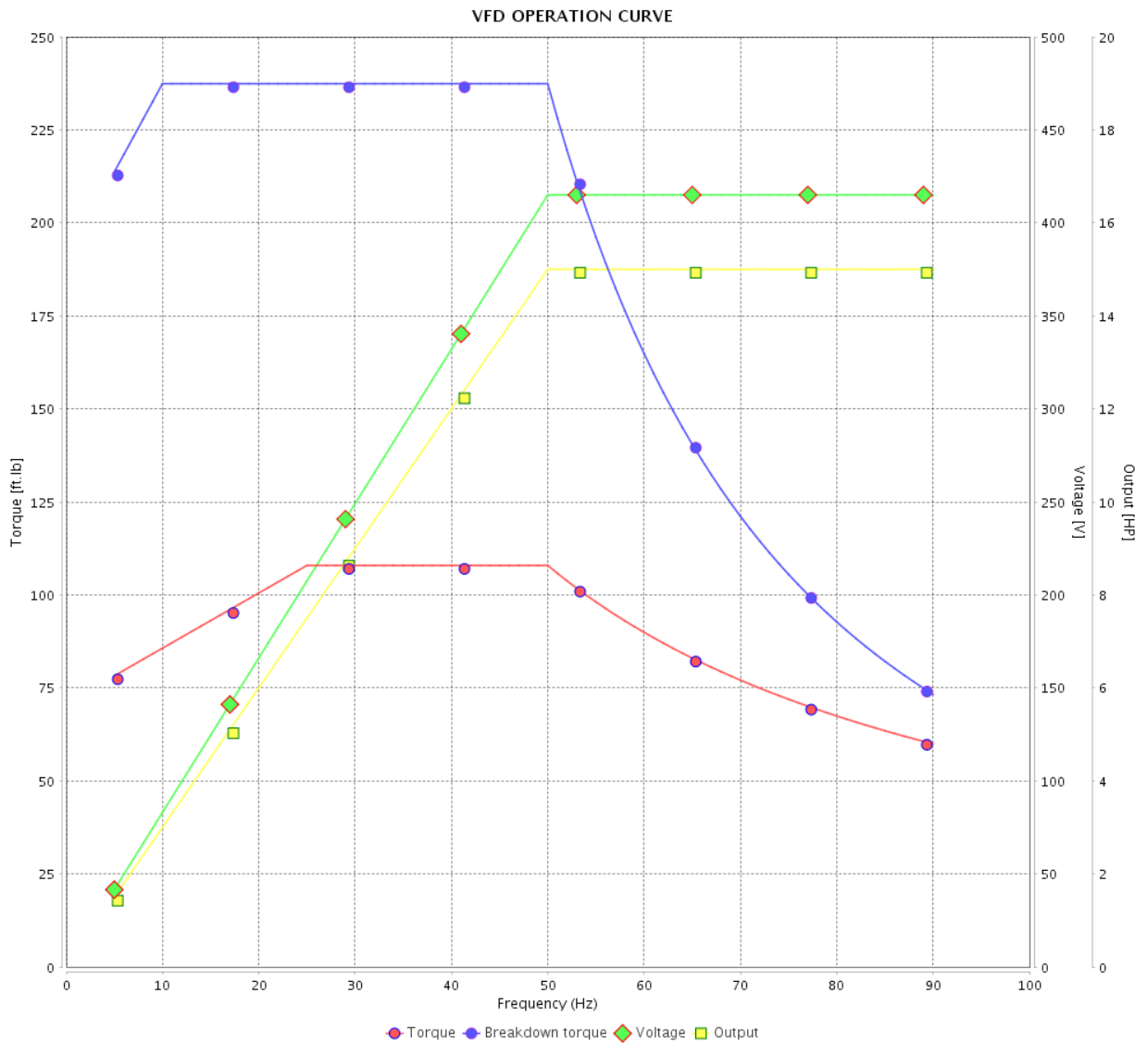

Performance : 415 V 50 Hz 8P IE3

Rated current : 22.1 A
 LRC : 5.1
 Rated torque : 108 ft.lb
 Locked rotor torque : 190 %
 Breakdown torque : 220 %
 Rated speed : 730 rpm

Moment of inertia (J) : 8.18 sq.ft.lb
 Duty cycle : Cont.(S1)
 Insulation class : F
 Service factor : 1.15
 Temperature rise : 105 K
 Design : B

Rev.	Changes Summary	Performed	Checked	Date
Performed by			Page 21 / 21	Revision
Checked by				
Date	13/04/2022			

1 2 3 4 5 6

A

B

C

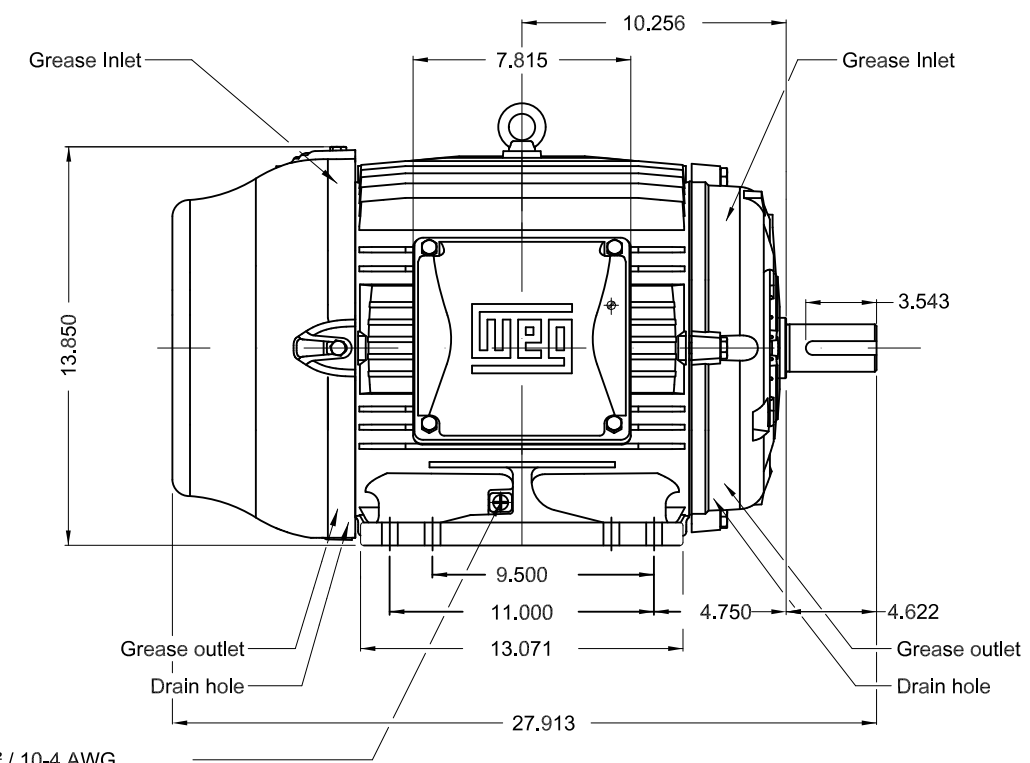
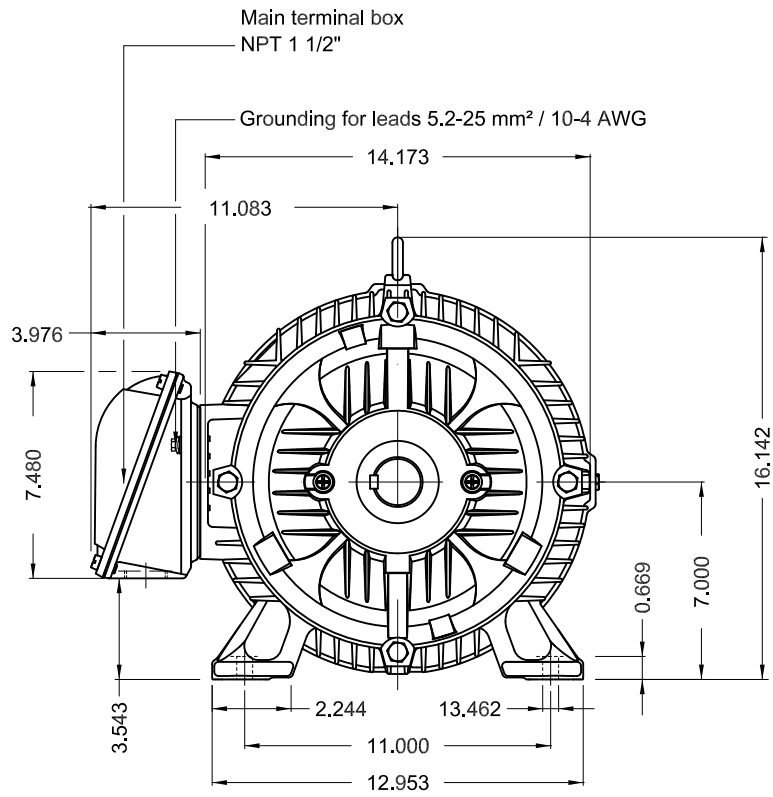

Grounding for leads 5.2-25 mm² / 10-4 AWG

D

E

Without vertical jackscrews
 Color RAL 5009
 Painting plan 202E
 Mounting B3R(D)

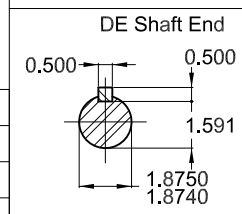

15 HP 08 Poles 60 Hz A

ECM	LOC	SUMMARY OF MODIFICATIONS	EXECUTED	CHECKED	RELEASED	DATE	VER
EXECUTED	PIRWBUSER	THREE PH. MOTOR IEEE 841 W22 PREM. EFF.					
CHECKED		FRAME 284/6T IP55 TEFC					
RELEASED							
REL DT.	WMO	Jaragua do Sul	Product Engineering	SHEET	1 / 1		

PREVIEW
 WDD



Dimensions in inches XME A3



NEMA
Premium
W22



FOR SAFE AREA
Mod.TE1BFOXON
CC029A



Class I, Div 2, Gr A, B, C and D - T3
Class I, Zone 2, IIC - T3
Class II, Div 2, Gr F and G - T4
For use on PWM: Gr. A, B, C, D and F,
VT 1000:1, CT 20:1, 1.00SF - T3A

MODEL 01509ST3QIE286T-W22



Inverter Duty Motor
Severe Duty

MADE IN BRAZIL
11584390

PH3 60Hz Fr. 284/6T 1000m.a.s.l. IP55 TEFC 421lb

V 460

A 19.6

HP 15

kW 11

SF 1.25

SFA 24.5

RPM 880

PF 0.78

AMB 40°C

INS cl. F DT80K

NEMA NOM EFF 90.2%

DUTY CONT.

DES B Code G

GUARANT. EFF 88.5%

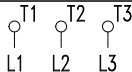

460V



→ 6311-C3 (18g) 55BC03X30

→ 6211-C3 (11g) 55BC02X30



MOBIL POLYREX EM (20000h)

