

DATA SHEET



Three Phase Induction Motor - Squirrel Cage

Customer :				
Product line	: NEMA Premium Efficiency Three-Phase	Product code :	12502647	
		Catalog # :	01518ET3E254T-S	
Frame	: 254/6T	Cooling method	: IC411 - TEFC	
Insulation class	: F	Mounting	: F-1	
Duty cycle	: Cont.(S1)	Rotation ¹	: Both (CW and CCW)	
Ambient temperature	: -20°C to +40°C	Starting method	: Direct On Line	
Altitude	: 1000 m.a.s.l.	Approx. weight ²	: 211 lb	
Protection degree	: IP55	Moment of inertia (J)	: 2.15 sq.ft.lb	
Design	: B			
Output [HP]	15	15	15	
Poles	4	4	4	
Frequency [Hz]	60	50	50	
Rated voltage [V]	230/460	190/380	220/415	
Rated current [A]	36.4/18.2	43.8/21.9	39.4/20.9	
L. R. Amperes [A]	237/118	241/120	240/127	
LRC [A]	6.5x(Code G)	5.5x(Code F)	6.1x(Code G)	
No load current [A]	17.3/8.65	17.1/8.53	17.5/9.28	
Rated speed [RPM]	1770	1455	1460	
Slip [%]	1.67	3.00	2.67	
Rated torque [ft.lb]	44.5	54.1	54.0	
Locked rotor torque [%]	250	190	210	
Breakdown torque [%]	300	229	260	
Service factor	1.15	1.00	1.00	
Temperature rise	80 K	105 K	105 K	
Locked rotor time	34s (cold) 19s (hot)	0s (cold) 0s (hot)	0s (cold) 0s (hot)	
Noise level ²	68.0 dB(A)	65.0 dB(A)	65.0 dB(A)	
Efficiency (%)	25%	90.8	92.5	91.9
	50%	91.0	91.5	91.2
	75%	92.4	91.2	91.4
	100%	92.4	89.9	90.4
Power Factor	25%	0.39	0.45	0.41
	50%	0.64	0.71	0.67
	75%	0.76	0.81	0.78
	100%	0.82	0.85	0.84
Bearing type	: <u>Drive end</u> 6309 Z C3 <u>Non drive end</u> 6208 Z C3	Foundation loads		
Sealing	: V'Ring Without Bearing Seal	Max. traction	: 567 lb	
		Max. compression	: 778 lb	
Lubrication interval	: 20000 h 20000 h			
Lubricant amount	: 13 g 8 g			
Lubricant type	: Mobil Polyrex EM			
Notes USABLE @208V 40.2A SF 1.00 SFA 40.2A				
This revision replaces and cancel the previous one, which must be eliminated. (1) Looking the motor from the shaft end. (2) Measured at 1m and with tolerance of +3dB(A). (3) Approximate weight subject to changes after manufacturing process. (4) At 100% of full load.		These are average values based on tests with sinusoidal power supply, subject to the tolerances stipulated in NEMA MG-1.		
Rev.	Changes Summary	Performed	Checked	Date
Performed by				
Checked by			Page	Revision
Date	13/04/2022		1 / 16	

TORQUE AND CURRENT VS SPEED CURVE

Three Phase Induction Motor - Squirrel Cage



Customer :

Product line : NEMA Premium Efficiency Three-Phase

Product code : 12502647

Catalog # : 01518ET3E254T-S

TORQUE AND CURRENT VS SPEED CURVE

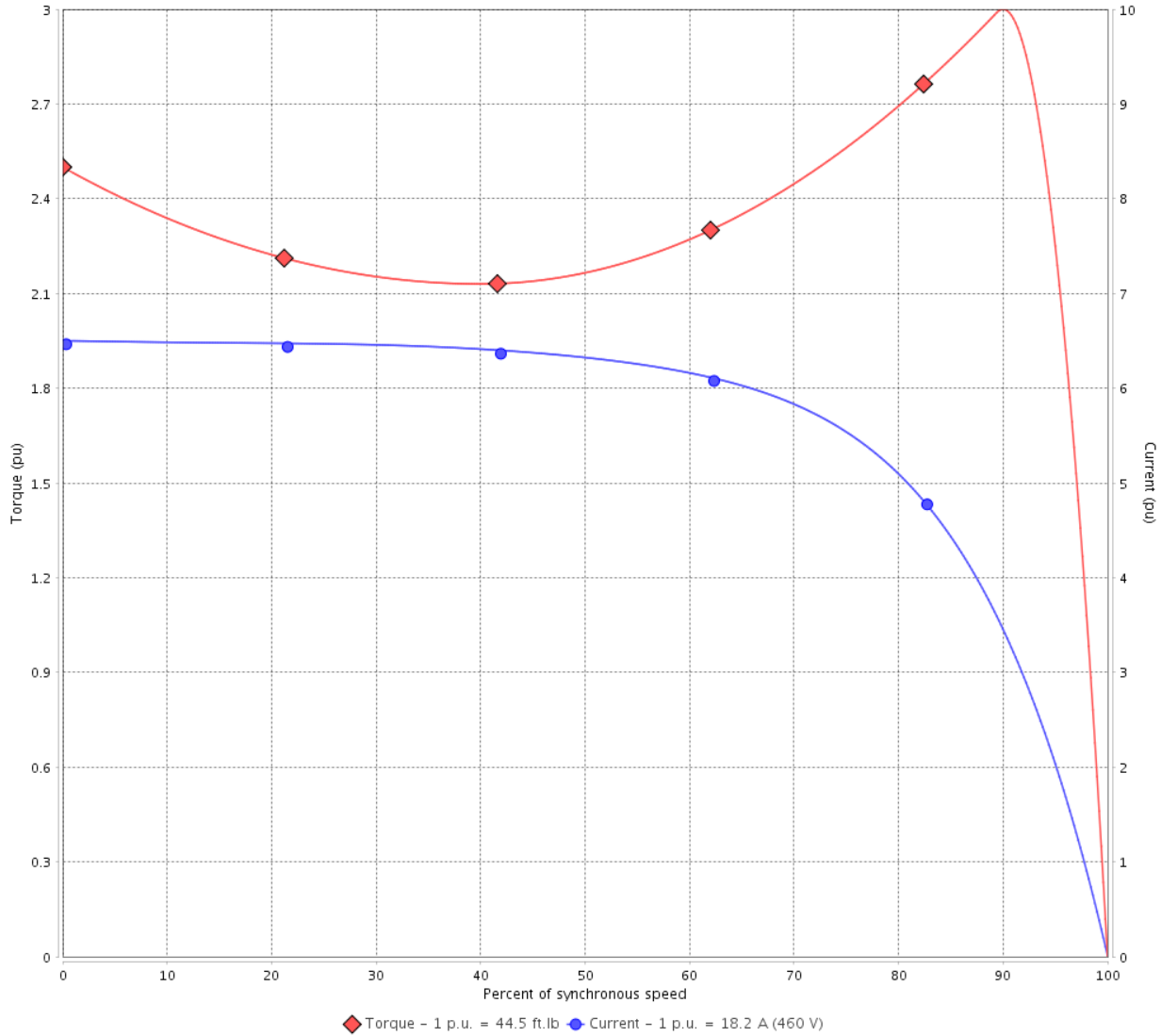

Performance : 230/460 V 60 Hz 4P

Rated current	: 36.4/18.2 A	Moment of inertia (J)	: 2.15 sq.ft.lb
LRC	: 6.5	Duty cycle	: Cont.(S1)
Rated torque	: 44.5 ft.lb	Insulation class	: F
Locked rotor torque	: 250 %	Service factor	: 1.15
Breakdown torque	: 300 %	Temperature rise	: 80 K
Rated speed	: 1770 rpm	Design	: B

Locked rotor time : 34s (cold) 19s (hot)

Rev.	Changes Summary	Performed	Checked	Date
Performed by			Page 2 / 16	Revision
Checked by				
Date	13/04/2022			

TORQUE AND CURRENT VS SPEED CURVE



Three Phase Induction Motor - Squirrel Cage

Customer :

Product line : NEMA Premium Efficiency Three-Phase

Product code : 12502647

Catalog # : 01518ET3E254T-S

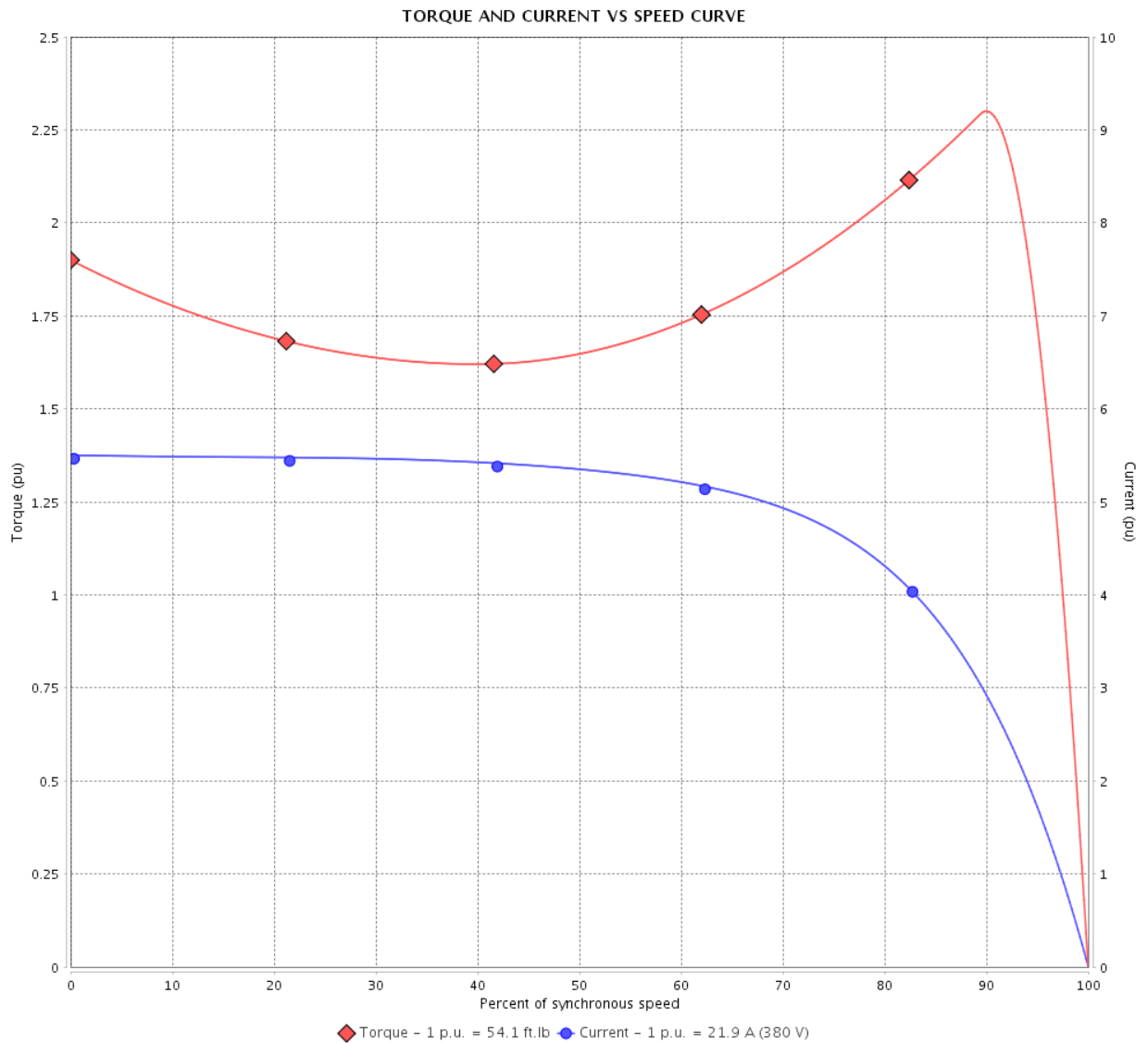

Performance : 190/380 V 50 Hz 4P

Rated current : 43.8/21.9 A
 LRC : 5.5
 Rated torque : 54.1 ft.lb
 Locked rotor torque : 190 %
 Breakdown torque : 229 %
 Rated speed : 1455 rpm

Moment of inertia (J) : 2.15 sq.ft.lb
 Duty cycle : Cont.(S1)
 Insulation class : F
 Service factor : 1.00
 Temperature rise : 105 K
 Design : B

Locked rotor time : 0s (cold) 0s (hot)

Rev.	Changes Summary	Performed	Checked	Date
Performed by		Page		Revision
Checked by		3 / 16		
Date		13/04/2022		

TORQUE AND CURRENT VS SPEED CURVE

Three Phase Induction Motor - Squirrel Cage



Customer :

Product line : NEMA Premium Efficiency Three-Phase

Product code : 12502647

Catalog # : 01518ET3E254T-S

TORQUE AND CURRENT VS SPEED CURVE

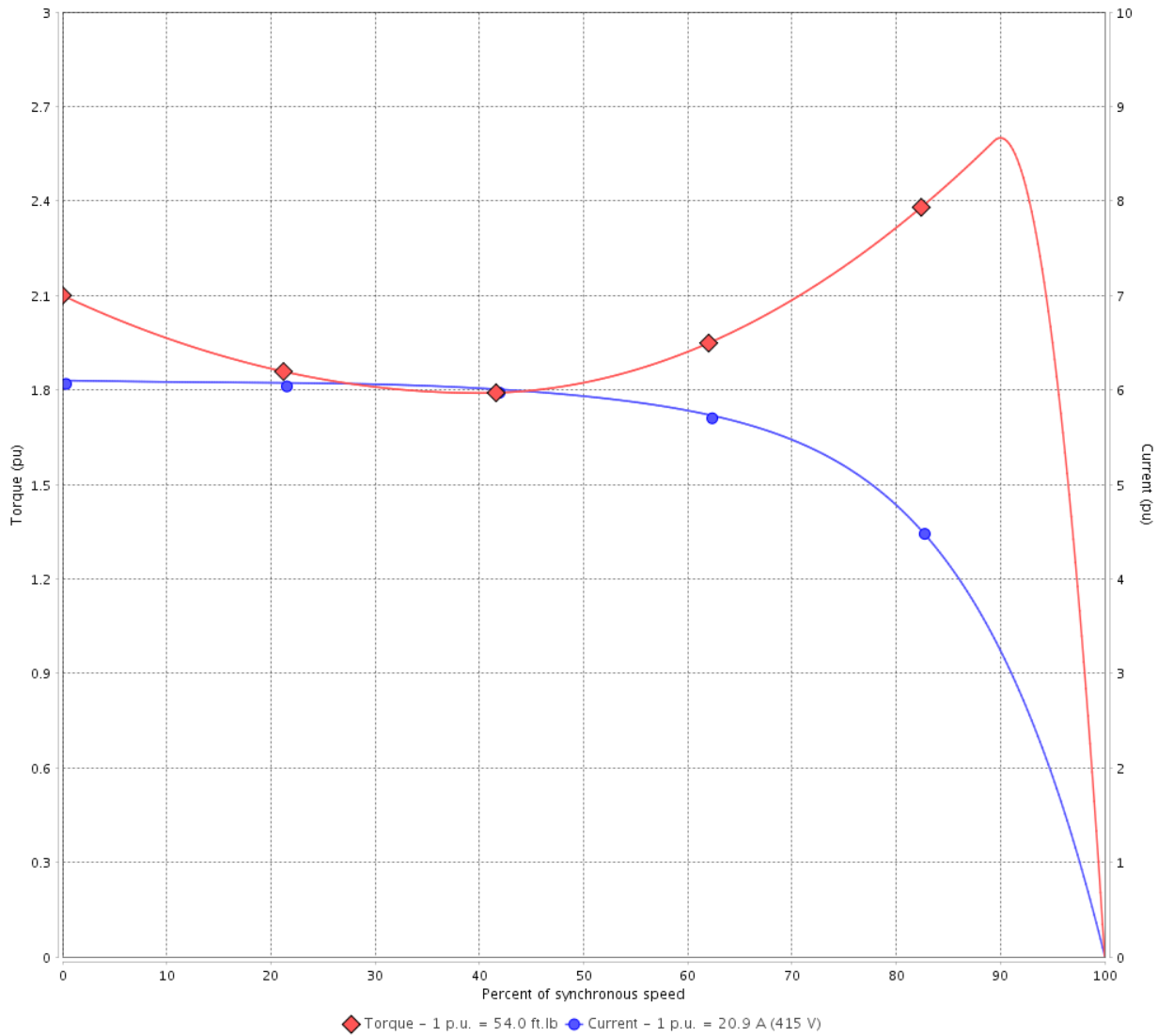

Performance : 220/415 V 50 Hz 4P

Rated current	: 39.4/20.9 A	Moment of inertia (J)	: 2.15 sq.ft.lb
LRC	: 6.1	Duty cycle	: Cont.(S1)
Rated torque	: 54.0 ft.lb	Insulation class	: F
Locked rotor torque	: 210 %	Service factor	: 1.00
Breakdown torque	: 260 %	Temperature rise	: 105 K
Rated speed	: 1460 rpm	Design	: B

Locked rotor time : 0s (cold) 0s (hot)

Rev.	Changes Summary	Performed	Checked	Date
Performed by			Page 4 / 16	Revision
Checked by				
Date	13/04/2022			

LOAD PERFORMANCE CURVE

Three Phase Induction Motor - Squirrel Cage



Customer :

Product line : NEMA Premium Efficiency Three-Phase

Product code : 12502647

Catalog # : 01518ET3E254T-S

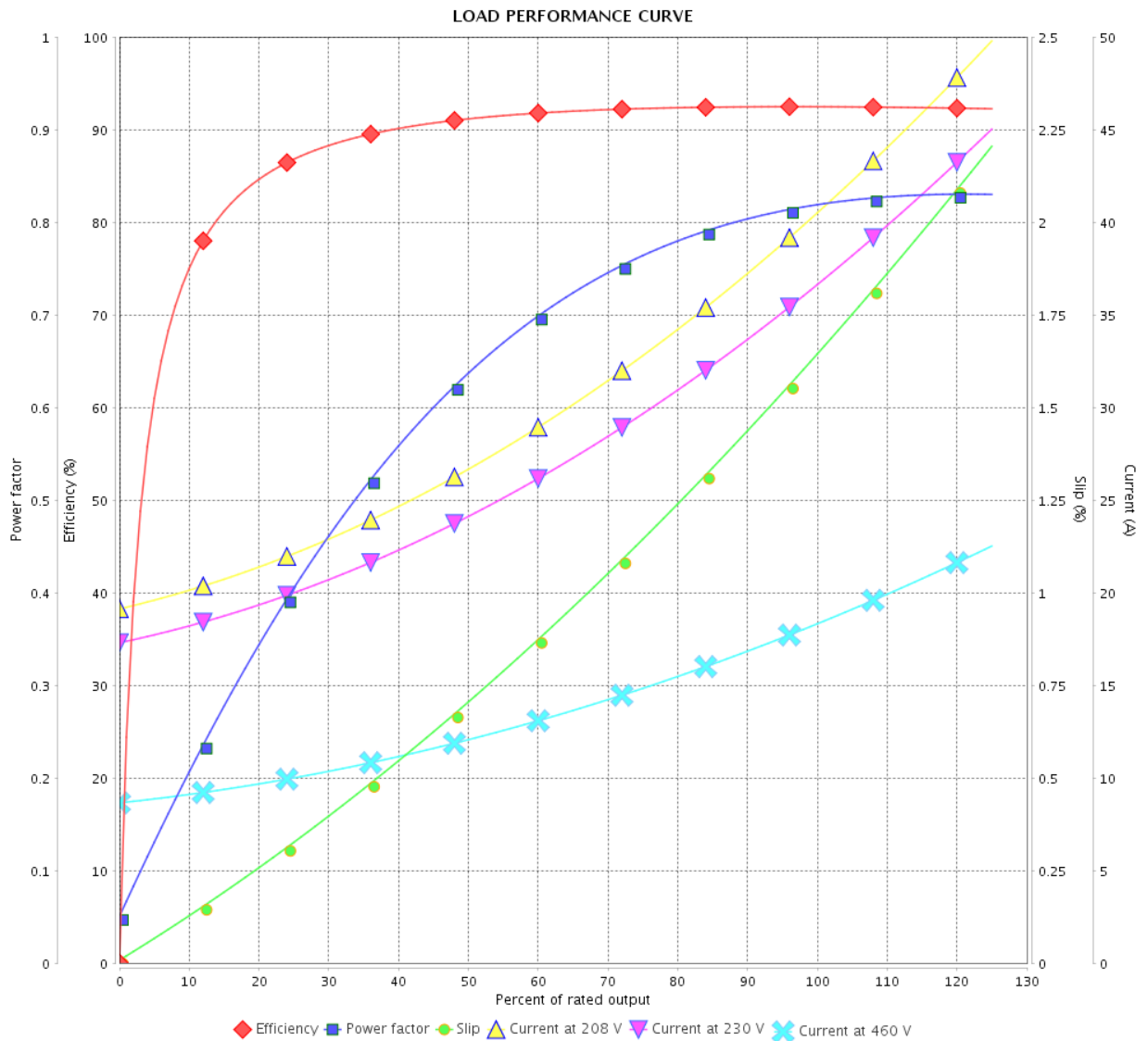

Performance : 230/460 V 60 Hz 4P

Rated current : 36.4/18.2 A
 LRC : 6.5
 Rated torque : 44.5 ft.lb
 Locked rotor torque : 250 %
 Breakdown torque : 300 %
 Rated speed : 1770 rpm

Moment of inertia (J) : 2.15 sq.ft.lb
 Duty cycle : Cont.(S1)
 Insulation class : F
 Service factor : 1.15
 Temperature rise : 80 K
 Design : B

Rev.	Changes Summary	Performed	Checked	Date
Performed by			Page	Revision
Checked by			5 / 16	
Date	13/04/2022			

LOAD PERFORMANCE CURVE

Three Phase Induction Motor - Squirrel Cage



Customer :

Product line : NEMA Premium Efficiency Three-Phase

Product code : 12502647

Catalog # : 01518ET3E254T-S

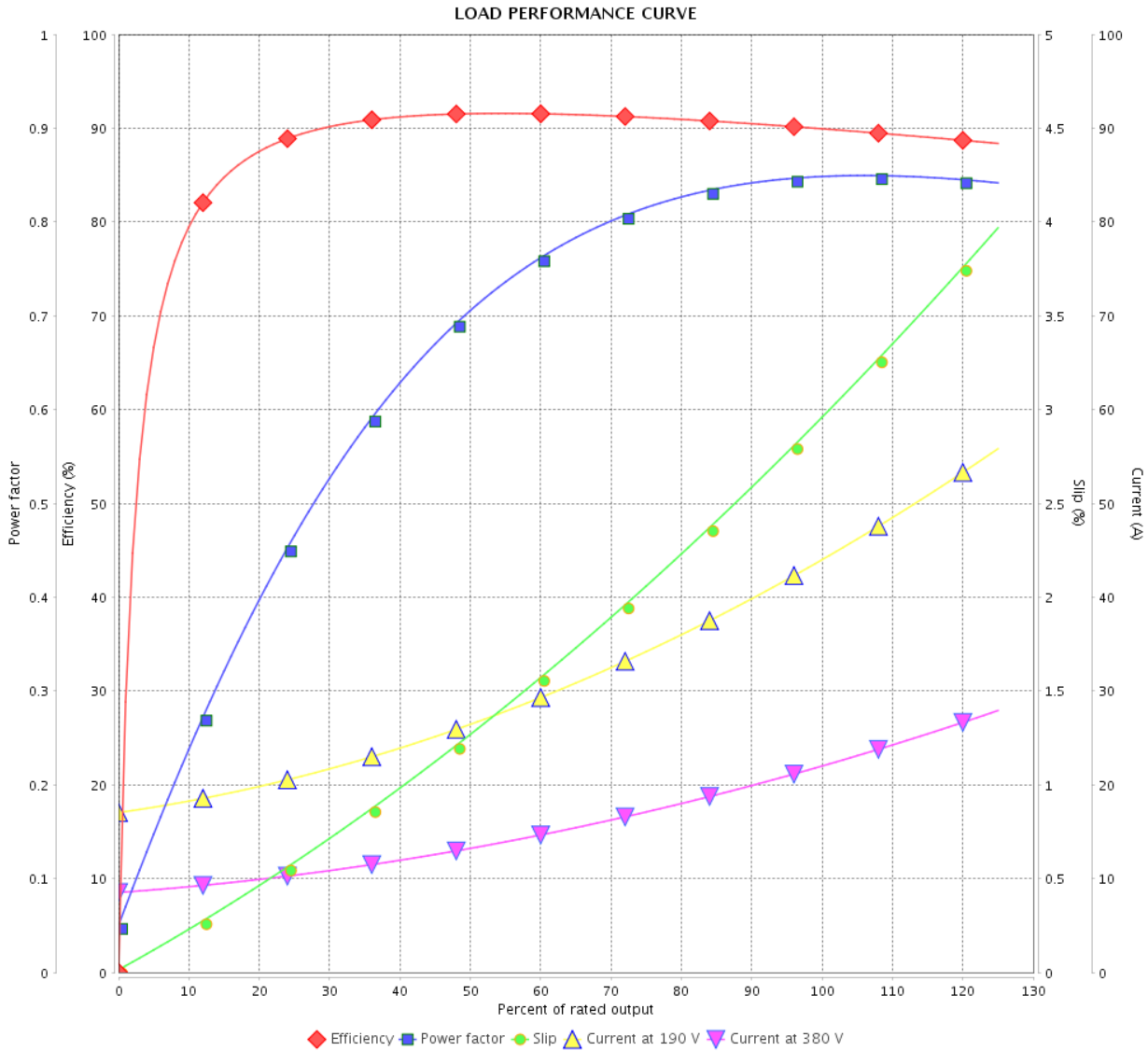

Performance : 190/380 V 50 Hz 4P

Rated current : 43.8/21.9 A
 LRC : 5.5
 Rated torque : 54.1 ft.lb
 Locked rotor torque : 190 %
 Breakdown torque : 229 %
 Rated speed : 1455 rpm

Moment of inertia (J) : 2.15 sq.ft.lb
 Duty cycle : Cont.(S1)
 Insulation class : F
 Service factor : 1.00
 Temperature rise : 105 K
 Design : B

Rev.	Changes Summary	Performed	Checked	Date
Performed by			Page	Revision
Checked by				
Date				

LOAD PERFORMANCE CURVE

Three Phase Induction Motor - Squirrel Cage



Customer :

Product line : NEMA Premium Efficiency Three-Phase

Product code : 12502647

Catalog # : 01518ET3E254T-S

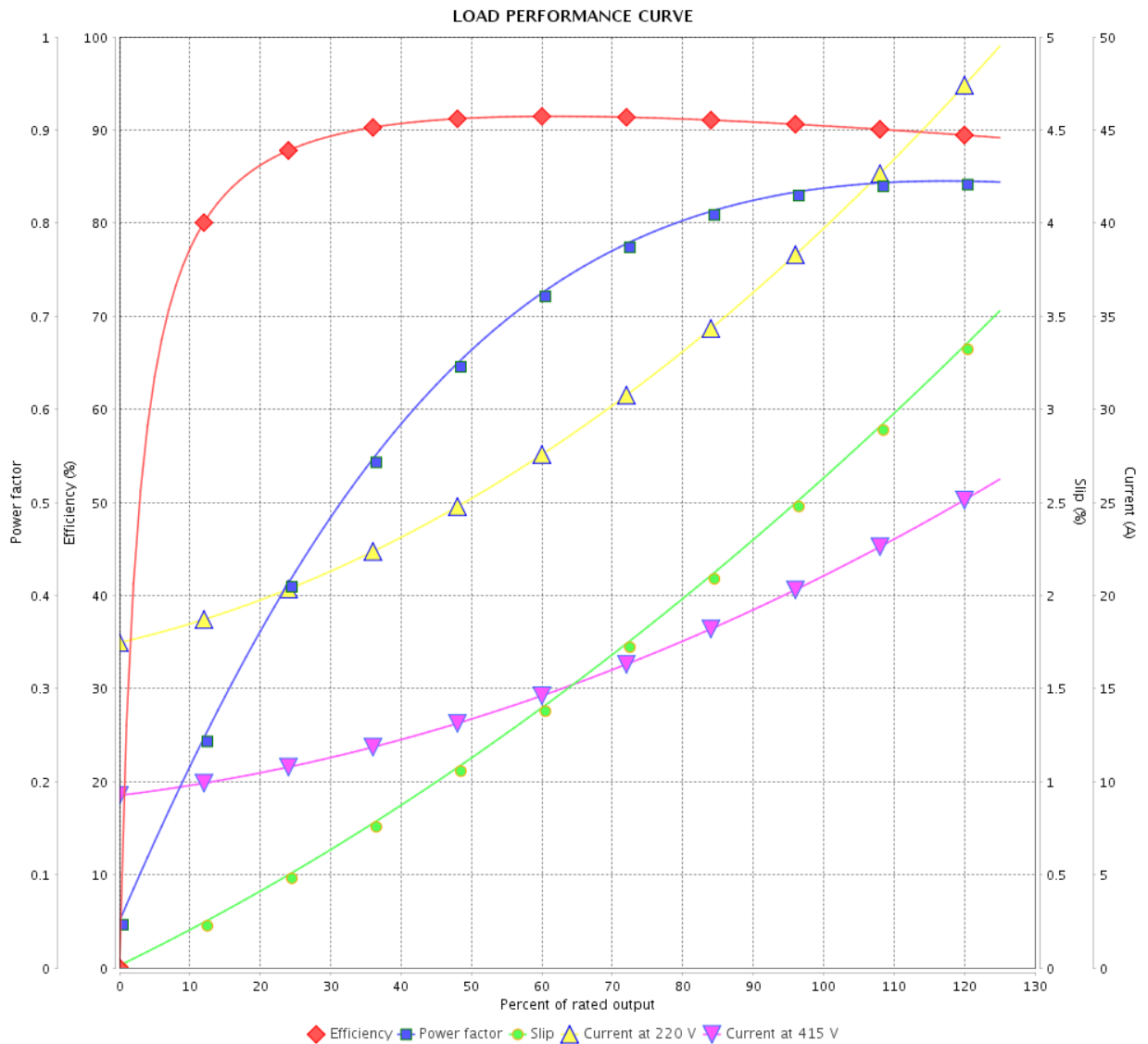

Performance : 220/415 V 50 Hz 4P

Rated current : 39.4/20.9 A
 LRC : 6.1
 Rated torque : 54.0 ft.lb
 Locked rotor torque : 210 %
 Breakdown torque : 260 %
 Rated speed : 1460 rpm

Moment of inertia (J) : 2.15 sq.ft.lb
 Duty cycle : Cont.(S1)
 Insulation class : F
 Service factor : 1.00
 Temperature rise : 105 K
 Design : B

Rev.	Changes Summary	Performed	Checked	Date
Performed by		Page		Revision
Checked by		7 / 16		
Date		13/04/2022		

THERMAL LIMIT CURVE



Three Phase Induction Motor - Squirrel Cage

Customer :

Product line : NEMA Premium Efficiency Three-Phase
Product code : 12502647
Catalog # : 01518ET3E254T-S

Performance : 230/460 V 60 Hz 4P

Rated current	: 36.4/18.2 A	Moment of inertia (J)	: 2.15 sq.ft.lb
LRC	: 6.5	Duty cycle	: Cont.(S1)
Rated torque	: 44.5 ft.lb	Insulation class	: F
Locked rotor torque	: 250 %	Service factor	: 1.15
Breakdown torque	: 300 %	Temperature rise	: 80 K
Rated speed	: 1770 rpm	Design	: B

Heating constant

Cooling constant

Rev.	Changes Summary	Performed	Checked	Date
Performed by				
Checked by			Page	Revision
Date	13/04/2022		8 / 16	

THERMAL LIMIT CURVE

Three Phase Induction Motor - Squirrel Cage



Customer : _____

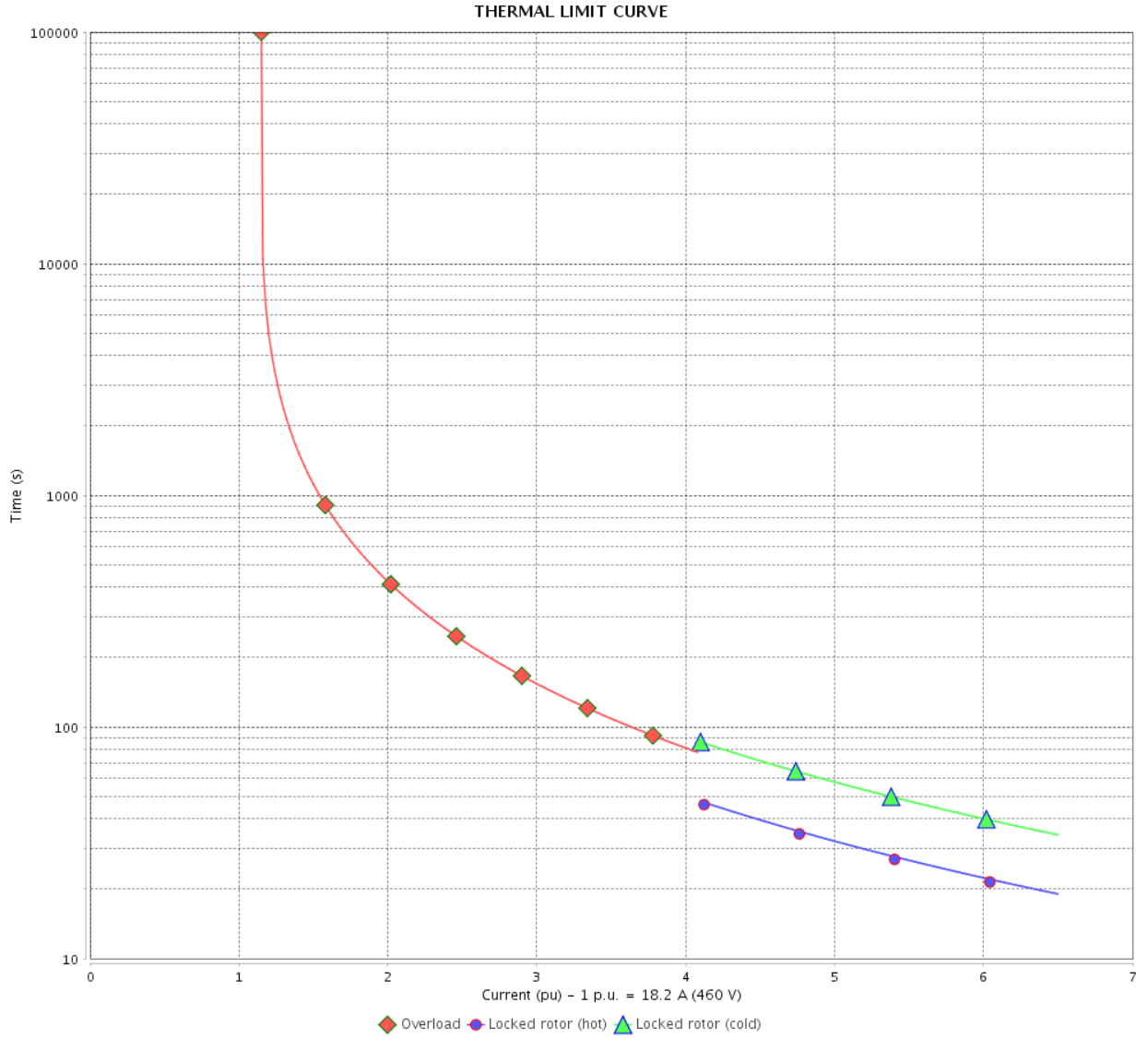

Rev.	Changes Summary	Performed	Checked	Date
Performed by		Page 9 / 16 Revision		
Checked by				
Date				

THERMAL LIMIT CURVE

Three Phase Induction Motor - Squirrel Cage



Customer :

Product line : NEMA Premium Efficiency Three-Phase
Product code : 12502647
Catalog # : 01518ET3E254T-S

Performance : 190/380 V 50 Hz 4P

Rated current	: 43.8/21.9 A	Moment of inertia (J)	: 2.15 sq.ft.lb
LRC	: 5.5	Duty cycle	: Cont.(S1)
Rated torque	: 54.1 ft.lb	Insulation class	: F
Locked rotor torque	: 190 %	Service factor	: 1.00
Breakdown torque	: 229 %	Temperature rise	: 105 K
Rated speed	: 1455 rpm	Design	: B

Heating constant

Cooling constant

Rev.	Changes Summary	Performed	Checked	Date
Performed by				
Checked by			Page	Revision
Date	13/04/2022		10 / 16	

THERMAL LIMIT CURVE

Three Phase Induction Motor - Squirrel Cage



Customer : _____

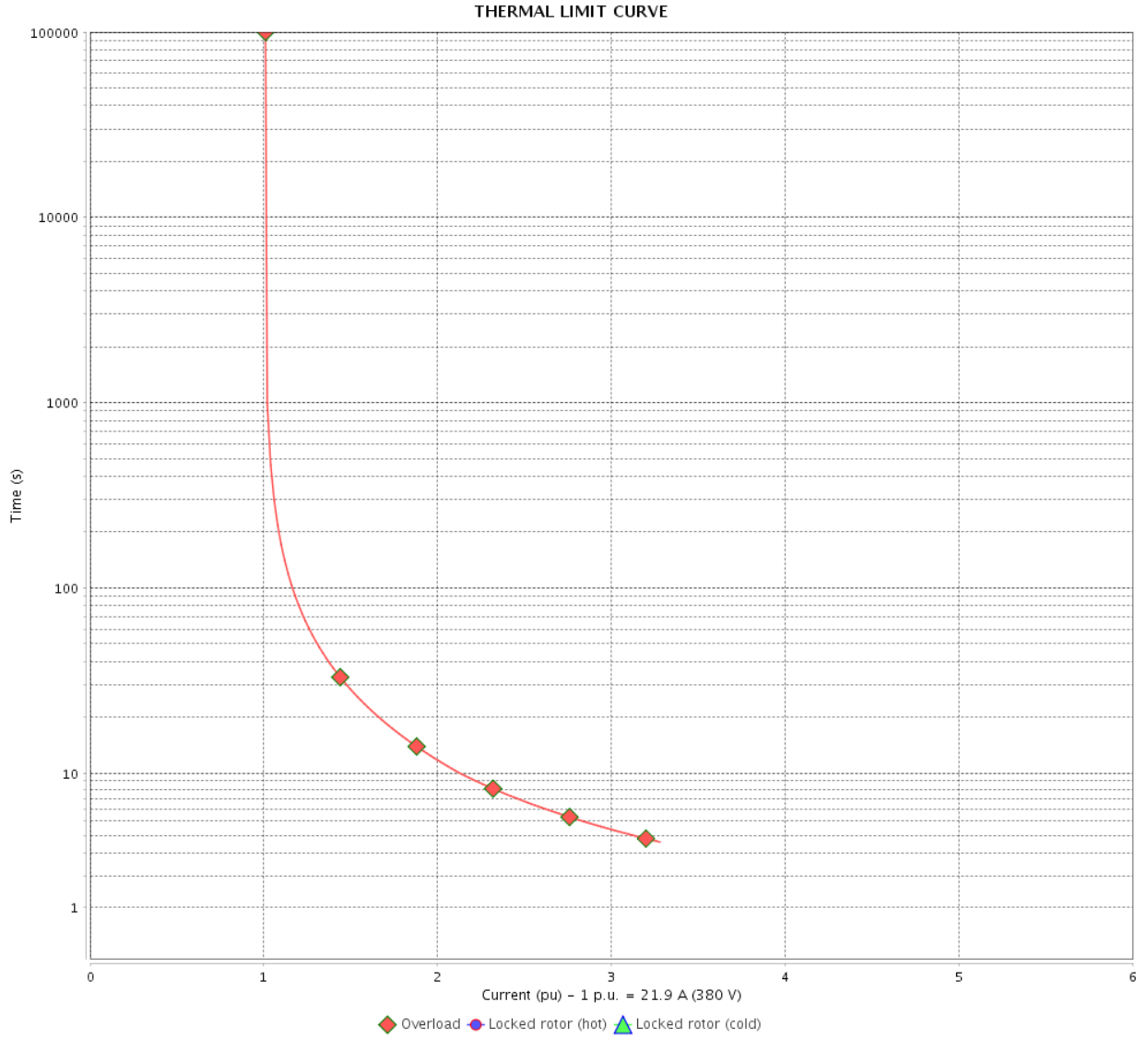

Rev.	Changes Summary	Performed	Checked	Date
Performed by		Page		Revision
Checked by		11 / 16		
Date		13/04/2022		

THERMAL LIMIT CURVE

Three Phase Induction Motor - Squirrel Cage



Customer :

Product line : NEMA Premium Efficiency Three-Phase
Product code : 12502647
Catalog # : 01518ET3E254T-S

Performance : 220/415 V 50 Hz 4P

Rated current	: 39.4/20.9 A	Moment of inertia (J)	: 2.15 sq.ft.lb
LRC	: 6.1	Duty cycle	: Cont.(S1)
Rated torque	: 54.0 ft.lb	Insulation class	: F
Locked rotor torque	: 210 %	Service factor	: 1.00
Breakdown torque	: 260 %	Temperature rise	: 105 K
Rated speed	: 1460 rpm	Design	: B

Heating constant

Cooling constant

Rev.	Changes Summary	Performed	Checked	Date
Performed by				
Checked by			Page	Revision
Date	13/04/2022		12 / 16	

THERMAL LIMIT CURVE

Three Phase Induction Motor - Squirrel Cage



Customer : _____

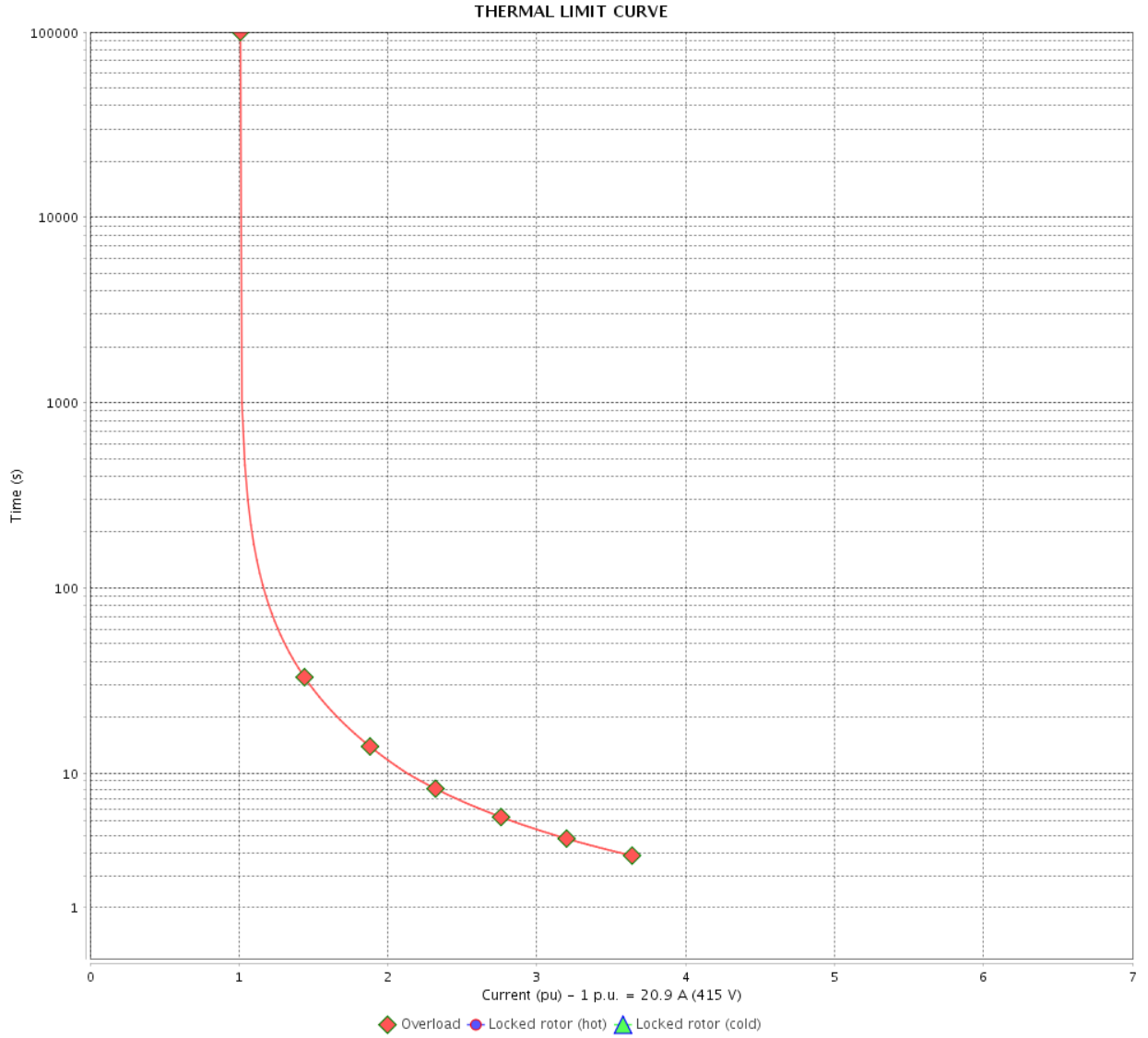

Rev.	Changes Summary	Performed	Checked	Date
Performed by		Page		Revision
Checked by		13 / 16		
Date		13/04/2022		

VFD OPERATION CURVE

Three Phase Induction Motor - Squirrel Cage



Customer :

Product line : NEMA Premium Efficiency Three-Phase

Product code : 12502647

Catalog # : 01518ET3E254T-S

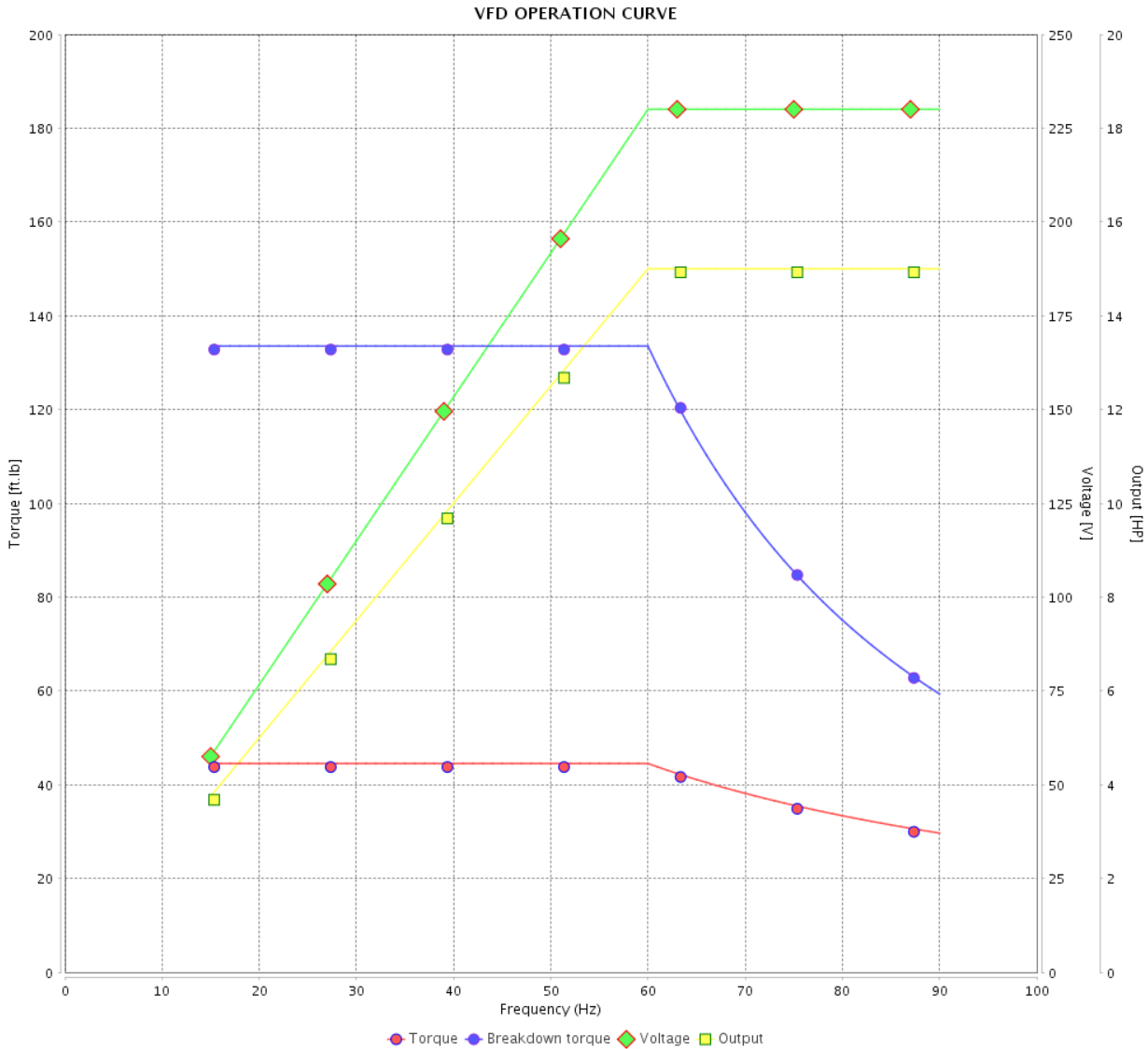

Performance : 230/460 V 60 Hz 4P

Rated current : 36.4/18.2 A
 LRC : 6.5
 Rated torque : 44.5 ft.lb
 Locked rotor torque : 250 %
 Breakdown torque : 300 %
 Rated speed : 1770 rpm

Moment of inertia (J) : 2.15 sq.ft.lb
 Duty cycle : Cont.(S1)
 Insulation class : F
 Service factor : 1.15
 Temperature rise : 80 K
 Design : B

Rev.	Changes Summary	Performed	Checked	Date
Performed by			Page	Revision
Checked by				
Date				

VFD OPERATION CURVE

Three Phase Induction Motor - Squirrel Cage



Customer :

Product line : NEMA Premium Efficiency Three-Phase

Product code : 12502647

Catalog # : 01518ET3E254T-S

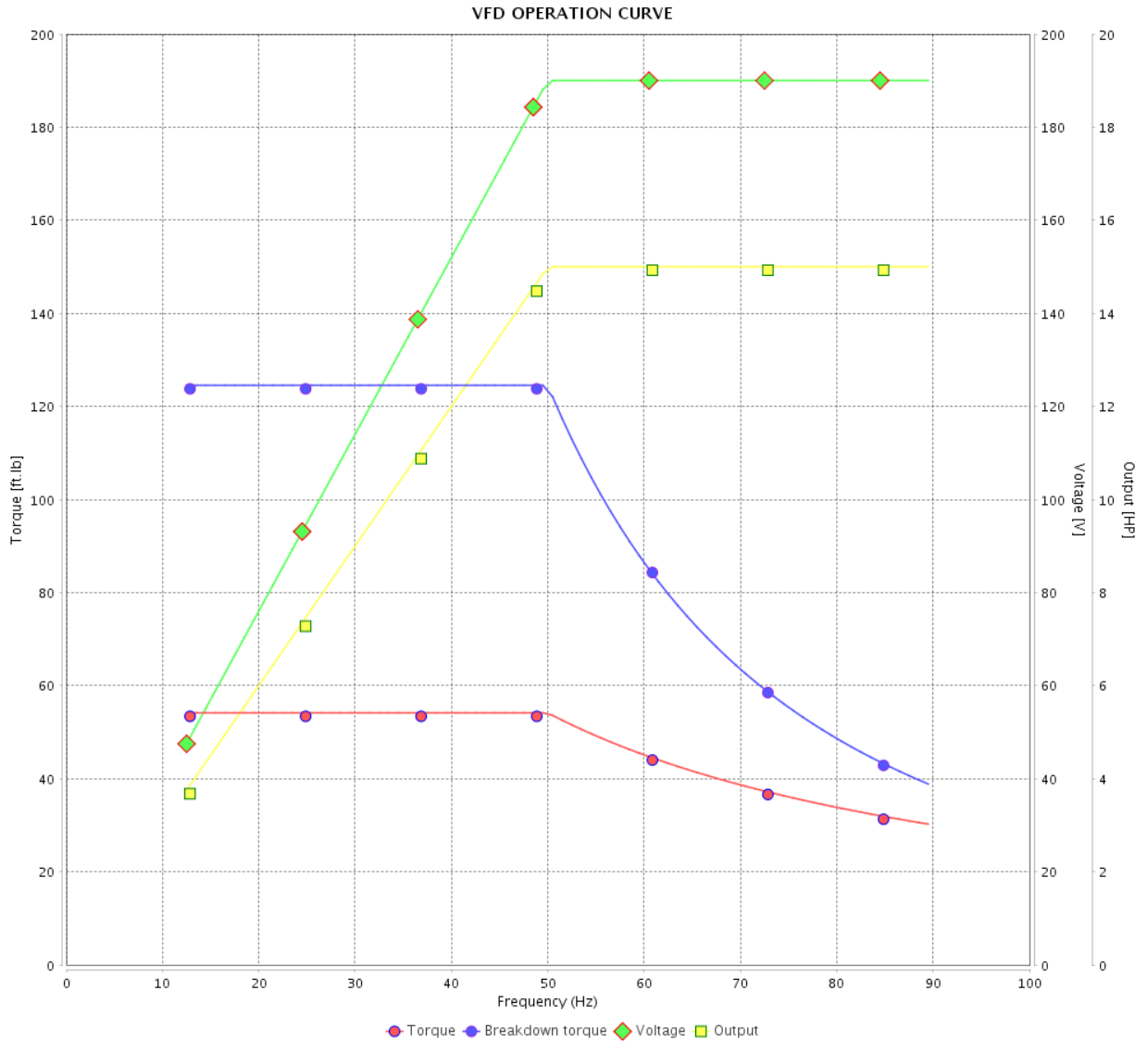

Performance : 190/380 V 50 Hz 4P

Rated current : 43.8/21.9 A
 LRC : 5.5
 Rated torque : 54.1 ft.lb
 Locked rotor torque : 190 %
 Breakdown torque : 229 %
 Rated speed : 1455 rpm

Moment of inertia (J) : 2.15 sq.ft.lb
 Duty cycle : Cont.(S1)
 Insulation class : F
 Service factor : 1.00
 Temperature rise : 105 K
 Design : B

Rev.	Changes Summary	Performed	Checked	Date
Performed by		Page		Revision
Checked by		15 / 16		
Date		13/04/2022		

VFD OPERATION CURVE

Three Phase Induction Motor - Squirrel Cage



Customer :

Product line : NEMA Premium Efficiency Three-Phase

Product code : 12502647

Catalog # : 01518ET3E254T-S

VFD OPERATION CURVE

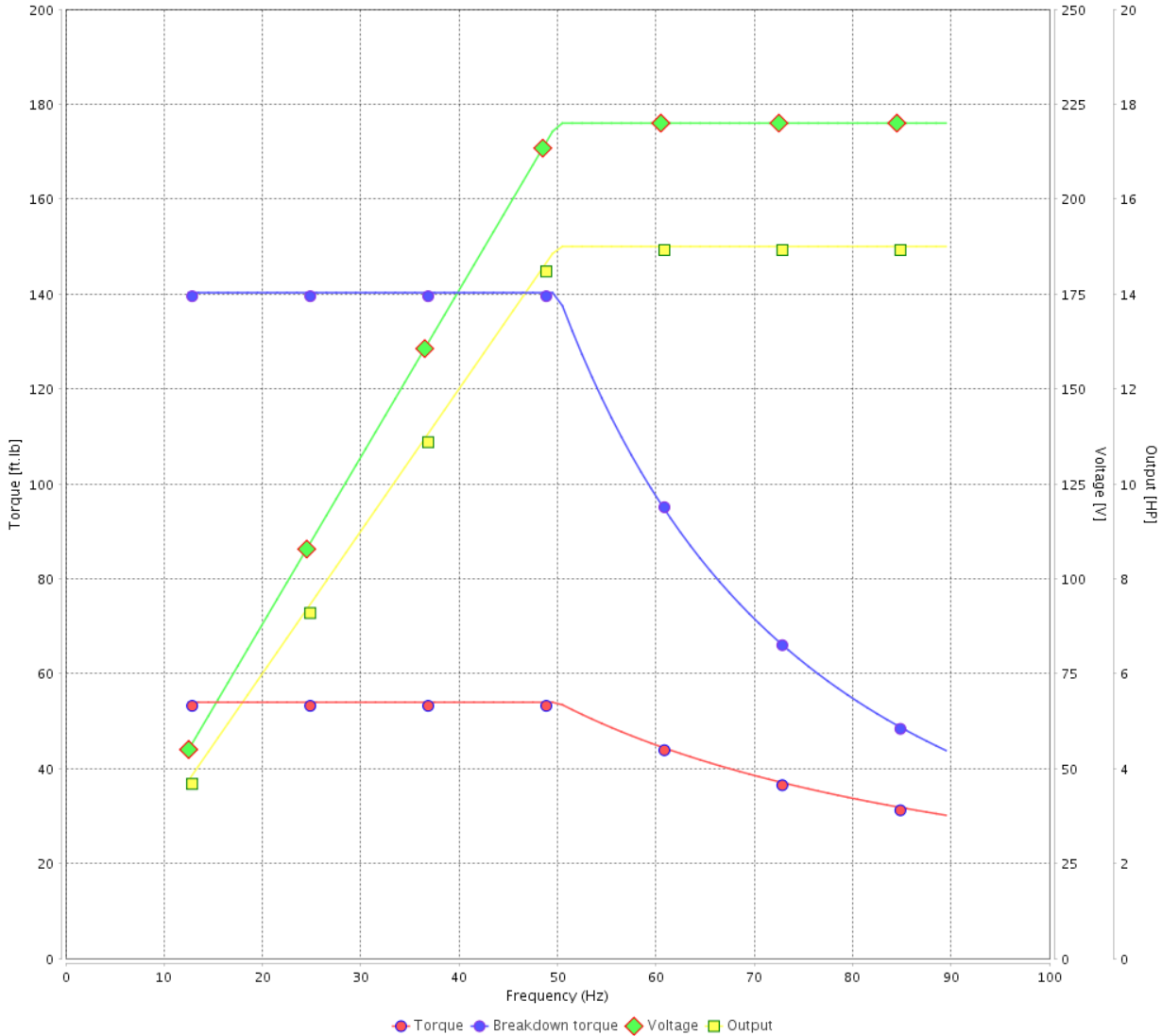

Performance : 220/415 V 50 Hz 4P

Rated current : 39.4/20.9 A
 LRC : 6.1
 Rated torque : 54.0 ft.lb
 Locked rotor torque : 210 %
 Breakdown torque : 260 %
 Rated speed : 1460 rpm

Moment of inertia (J) : 2.15 sq.ft.lb
 Duty cycle : Cont.(S1)
 Insulation class : F
 Service factor : 1.00
 Temperature rise : 105 K
 Design : B

Rev.	Changes Summary	Performed	Checked	Date
Performed by			Page 16 / 16	Revision
Checked by				
Date	13/04/2022			

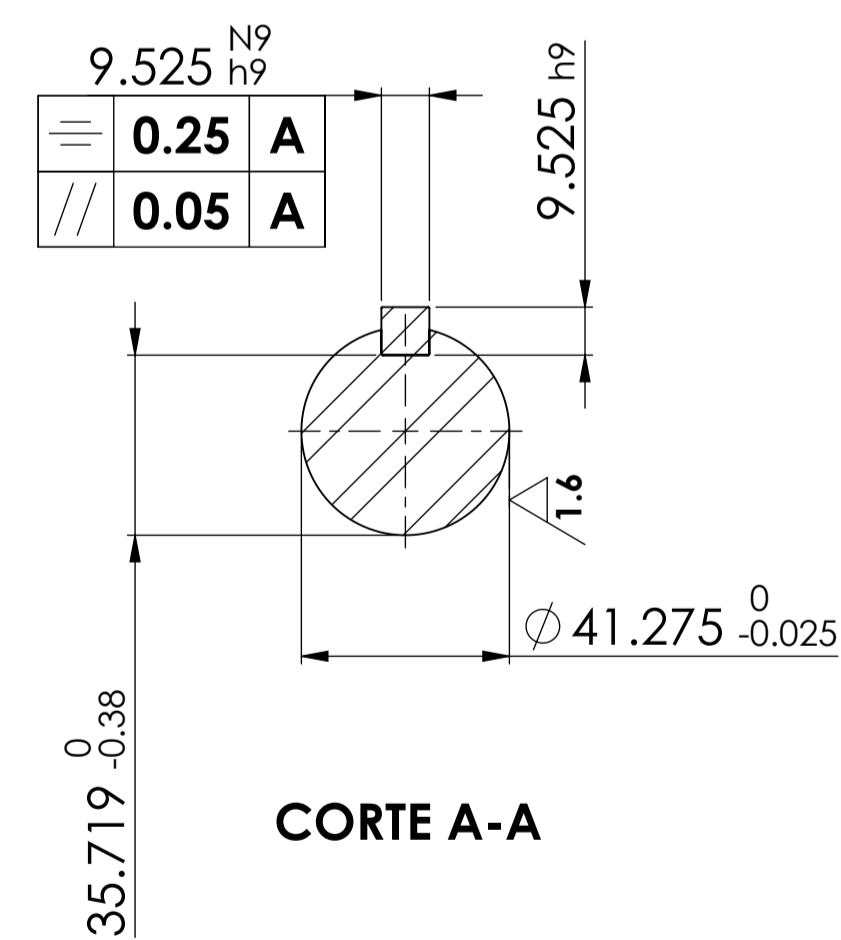
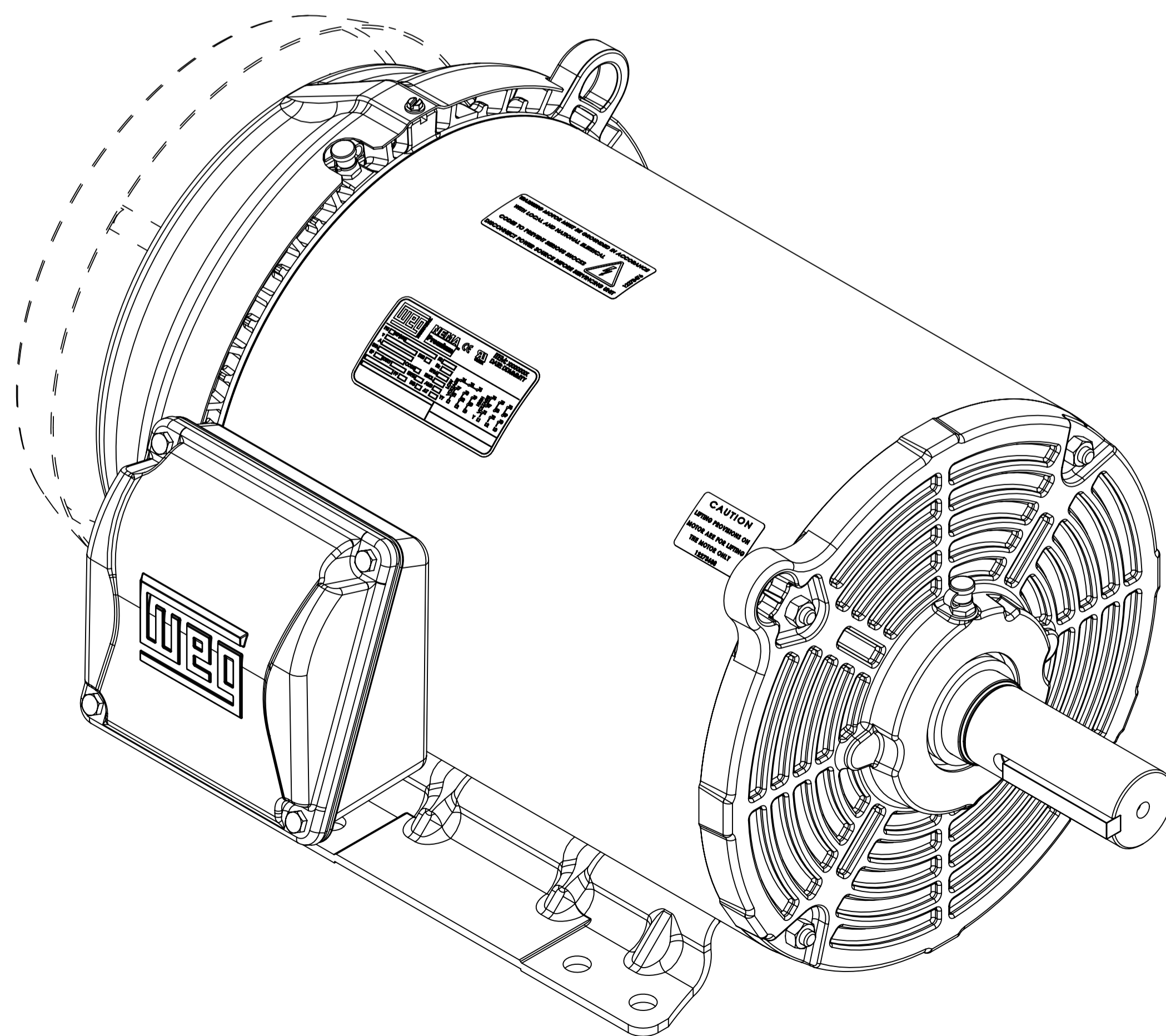
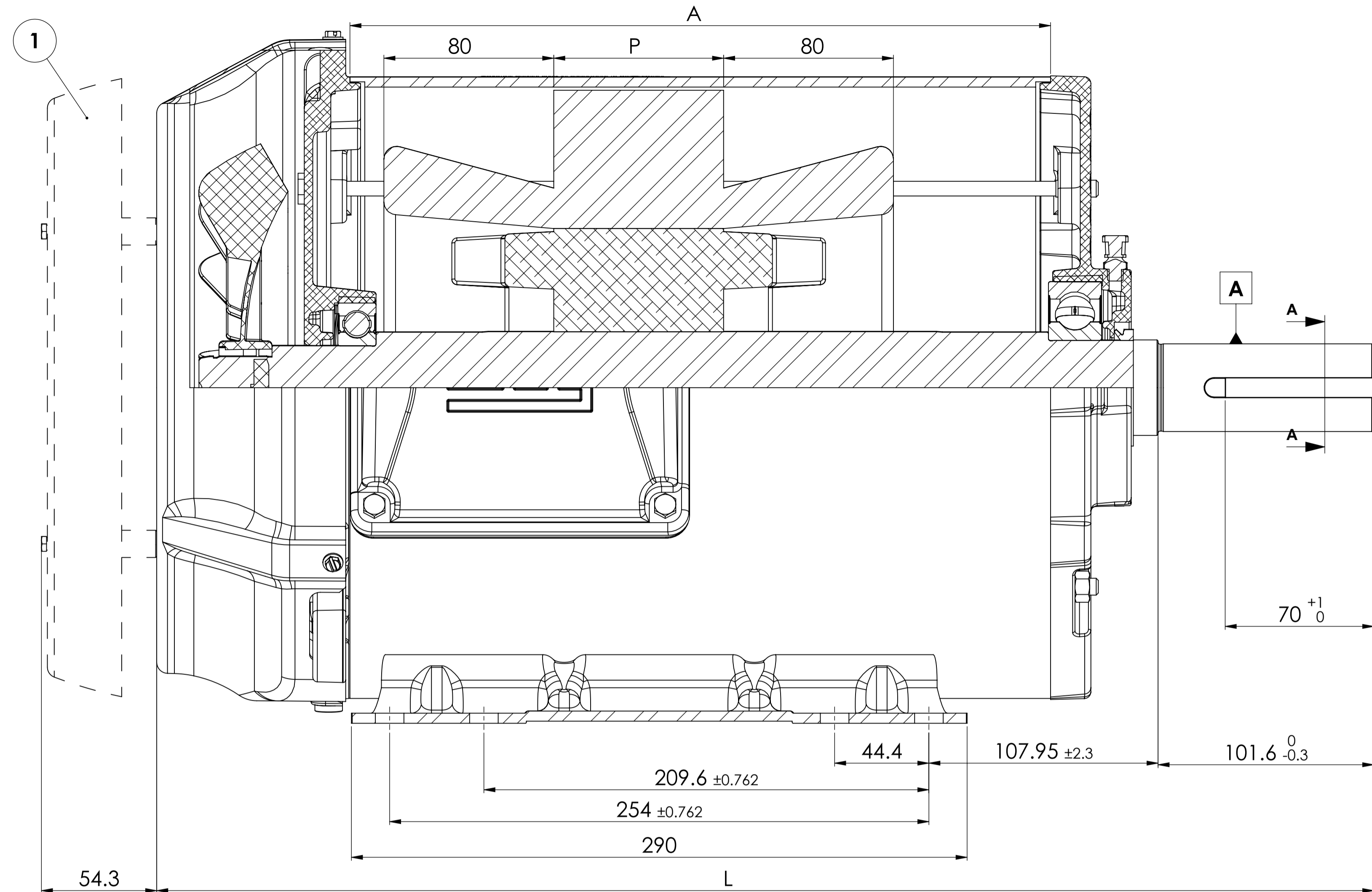
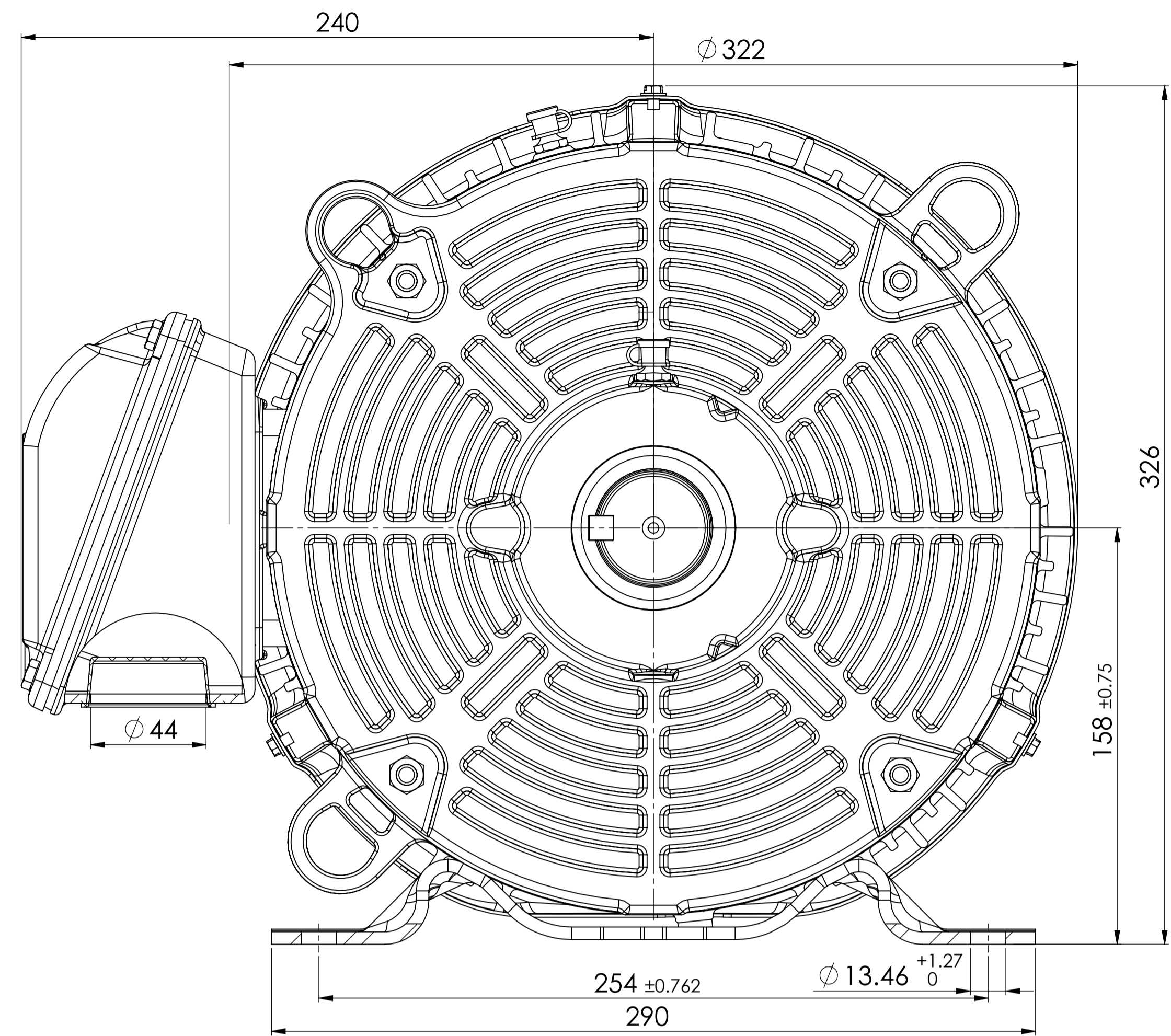

Pos. Drenos	Horizontal		Vertical (eixo para baixo)		Vertical (eixo para cima)	
	Traseira	Dianteira	Traseira	Dianteira	Traseira	Dianteira
N56 143/5T	Tampa	Carcaça	Tampa	Carcaça (*)	Tampa	Carcaça
182/4T	Tampa	Tampa (**)	Tampa	Tampa (**)	Tampa	Tampa (**)
213/5T	Carcaça (***)	Carcaça	Carcaça (***)	Tampa (**)	Tampa	Carcaça
254/6T	Tampa	Carcaça	Tampa	Tampa (**)	Tampa	Carcaça

* Motor com flange, o dreno vai na tampa flangeada.
 ** Tampa normal ou flangeada.
 *** Motores com tampa flangeada e com carcaças menores que 290mm, o dreno vai na tampa traseira.

Cotas / Carcaça	330	350
A	330	350
P	80-140	150-170
L	573	593

1. SOMENTE QUANDO INDICADO NA LISTA TÉCNICA DO MOTOR

Cabeça de Bobina	F1	F2
II	80	80
IV - VI	65	65

MASSA BRUTA/GROSS WEIGHT		MASSA LÍQUIDA/NET WEIGHT		ESCALA/SCALE	
500001081712	REVISÃO NORMA CABEÇA BOBINA	JROPELATO	JHONATANP	02.09.2015	05
500000886238	ALT. CONF. CLAIM 413416105	PMAUERBERG	ALISSON	16.05.2014	04
ECM	LOC	RESUMO DE MODIFICAÇÕES / SUMMARY OF MODIFICATIONS		EXECUTADO / CHECKED	LIBERADO / RELEASED
EXEC	RAFAELLOPES	DIMENSIONAL 254 TEFC TPA NORMAL		10002037738	
VERIFICADO / CHECKED	JTOGNERI			000	05
LIBERADO / RELEASED	24.04.2013	WMO	JARAGUÁ DO SUL	DESENVOLVIMENTO DE PRODUTO	FOLHETA 1 / 1

**NEMA**
Premium

MADE IN MEXICO

MAT: 12502647 CC029A
W01.TE0IC0X0N
MODEL 01518ET3E254T-S
18MAR2022 S/N:**For 60Hz: Class I, Zone 2, IIC**
Class I, Div.2, Gr. A,B,C,D - T3
Div 2 Inverter Duty (SF1.00)
CT 2:1/VT 1000:1

PH 3	Hz 60	HP 15
FR 254/6T		KW 11
DUTY CONT.		V 230/460
ALT 1000 m.a.s.l.		A 36.4/18.2
INS CL F AT 80K	IP55	SFA 41.9/20.9
AMB 40°C	DES B	SF 1.15
ENCL TEFC	CODE G	PF 0.82
USABLE @ 208V 40.3A		RPM 1770
SF1.00		NEMA NOM. EFF 92.4%

ALTERNATE RATING: 15HP 50Hz 190-220/380-415V SF1.00
43.8-38.9/21.9-20.6A 1455RPM EFF 89.9% (IE2) IEC 60034-1

For safe area-inverter duty motor For 60Hz use on VPWM 1000:1 VT, 4:1 CT

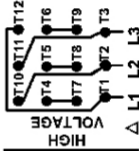
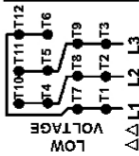
DE 6309-Z-C3 ODE 6208-Z-C3 MOBIL POLYREX EM 20000hT1-BLU T2-WHT
T3-ORG T4-YEL
T5-BLK T6-GRY
T7-PNK T8-RED
T9-BRK RED
T10-CURRY
T11-GRN T12-VLT

INTERCHANGE ANY TWO LINE WIRES TO REVERSE THE ROTATION

WARNING: Motor must be grounded in accordance with local and national electrical codes to prevent serious electrical shocks. Disconnect power source before servicing unit.**AVERTISSEMENT:** Le moteur doit être mis à la terre conformément aux codes électriques locaux et nationaux afin d'éviter tout choc électrique grave. Déconnectez l'alimentation avant l'entretien de la machine.