

DATA SHEET



Three Phase Induction Motor - Squirrel Cage

Customer :				
Product line	: NEMA Premium Efficiency Three-Phase			
Product code :	12727369			
Catalog # :	01518OT3P254T-S			
Frame : 254/6T Output : 15 HP (11 kW) Poles : 4 Frequency : 60 Hz Rated voltage : 200 V Rated current : 42.8 A L. R. Amperes : 287 A LRC : 6.7x(Code H) No load current : 21.9 A Rated speed : 1775 rpm Slip : 1.39 % Rated torque : 44.4 ft.lb Locked rotor torque : 240 % Breakdown torque : 300 % Insulation class : F Service factor : 1.15 Moment of inertia (J) : 1.82 sq.ft.lb Design : B	Locked rotor time : 30s (cold) 17s (hot) Temperature rise : 80 K Duty cycle : Cont.(S1) Ambient temperature : -20°C to +40°C Altitude : 1000 m.a.s.l. Cooling method : IC01 - ODP Mounting : F-1 Rotation ¹ : Both (CW and CCW) Noise level ² : 64.0 dB(A) Starting method : Direct On Line Approx. weight ³ : 189 lb			
Output	25% 50% 75% 100%			
Efficiency (%)	91.0 91.7 92.4 93.0			
Power Factor	0.36 0.62 0.73 0.80			
Foundation loads				
Max. traction	: 544 lb			
Max. compression	: 733 lb			
Bearing type	: <u>Drive end</u> 6309 Z C3 <u>Non drive end</u> 6208 Z C3			
Sealing	: Without Bearing Seal Without Bearing Seal			
Lubrication interval	: 20000 h 20000 h			
Lubricant amount	: 13 g 8 g			
Lubricant type	: Mobil Polyrex EM			
Notes				
This revision replaces and cancel the previous one, which must be eliminated. (1) Looking the motor from the shaft end. (2) Measured at 1m and with tolerance of +3dB(A). (3) Approximate weight subject to changes after manufacturing process. (4) At 100% of full load.				
These are average values based on tests with sinusoidal power supply, subject to the tolerances stipulated in NEMA MG-1.				
Rev.	Changes Summary	Performed	Checked	Date
Performed by				
Checked by			Page	Revision
Date	13/04/2022		1 / 6	

TORQUE AND CURRENT VS SPEED CURVE

Three Phase Induction Motor - Squirrel Cage



Customer :

Product line : NEMA Premium Efficiency Three-Phase

Product code : 12727369

Catalog # : 01518OT3P254T-S

TORQUE AND CURRENT VS SPEED CURVE

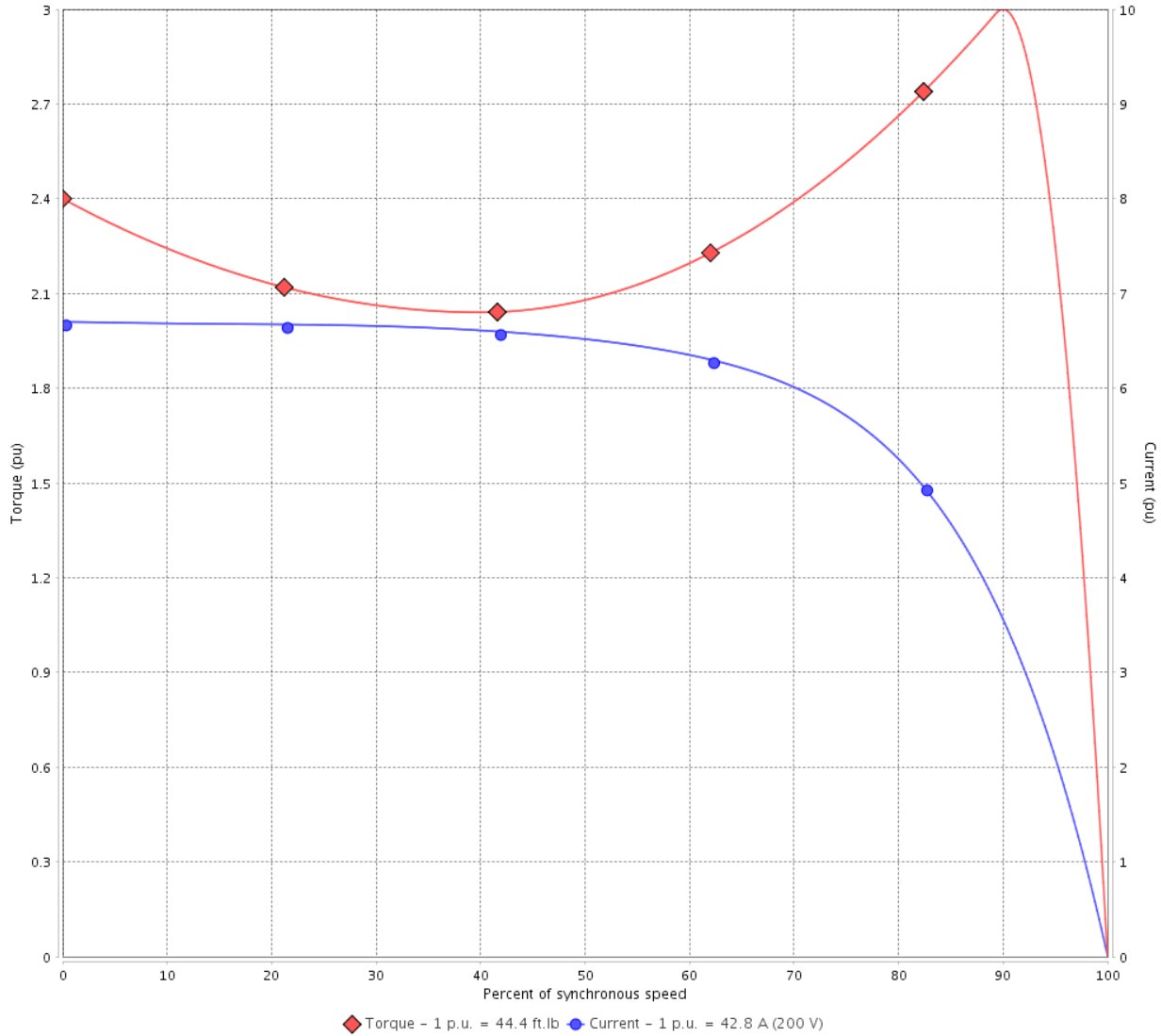

Performance : 200 V 60 Hz 4P

Rated current	: 42.8 A	Moment of inertia (J)	: 1.82 sq.ft.lb
LRC	: 6.7	Duty cycle	: Cont.(S1)
Rated torque	: 44.4 ft.lb	Insulation class	: F
Locked rotor torque	: 240 %	Service factor	: 1.15
Breakdown torque	: 300 %	Temperature rise	: 80 K
Rated speed	: 1775 rpm	Design	: B

Locked rotor time : 30s (cold) 17s (hot)

Rev.	Changes Summary	Performed	Checked	Date
Performed by			Page 2 / 6	Revision
Checked by				
Date	13/04/2022			

LOAD PERFORMANCE CURVE

Three Phase Induction Motor - Squirrel Cage



Customer :

Product line : NEMA Premium Efficiency Three-Phase

Product code : 12727369

Catalog # : 01518OT3P254T-S

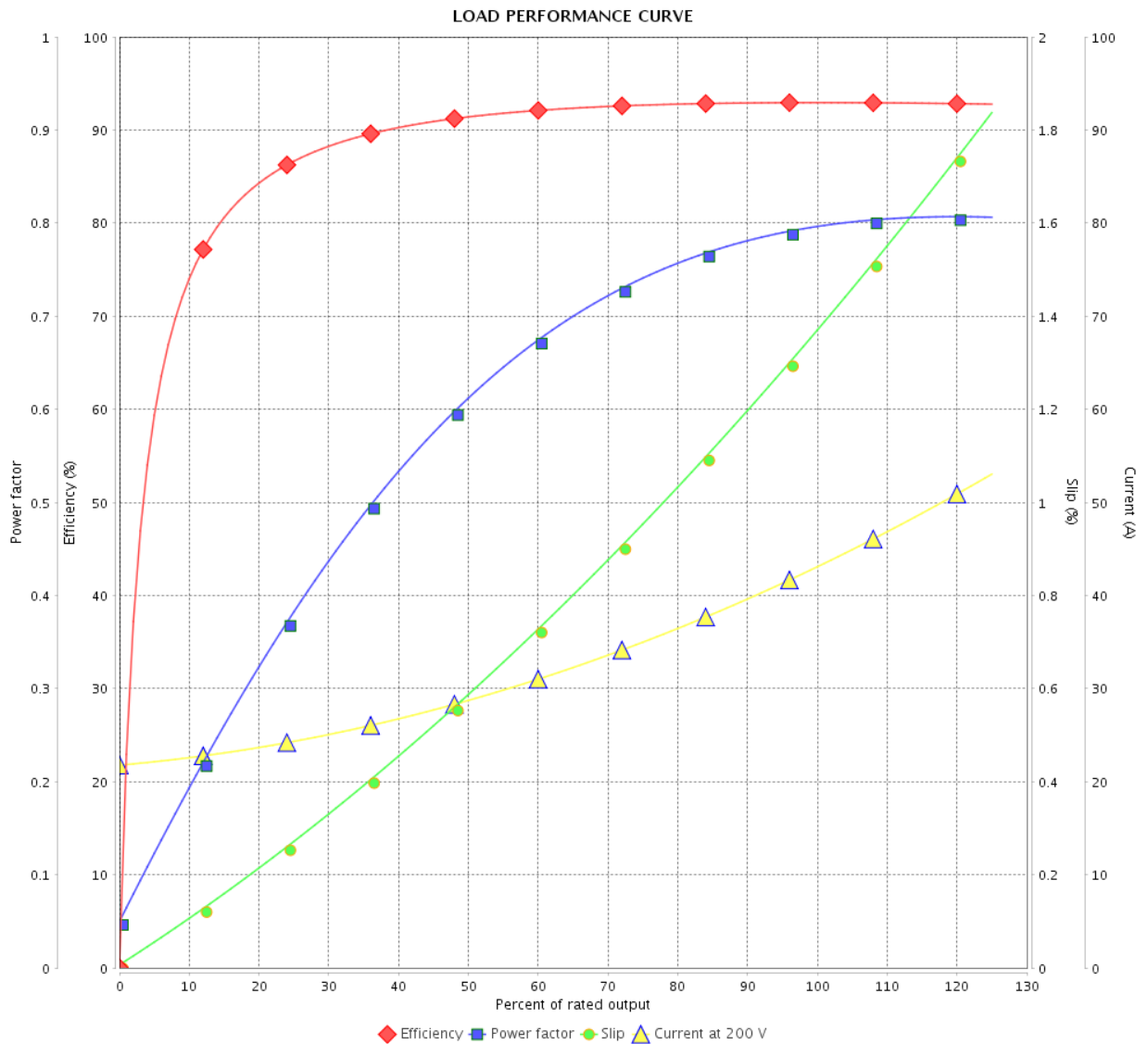

Performance : 200 V 60 Hz 4P

Rated current : 42.8 A
 LRC : 6.7
 Rated torque : 44.4 ft.lb
 Locked rotor torque : 240 %
 Breakdown torque : 300 %
 Rated speed : 1775 rpm

Moment of inertia (J) : 1.82 sq.ft.lb
 Duty cycle : Cont.(S1)
 Insulation class : F
 Service factor : 1.15
 Temperature rise : 80 K
 Design : B

Rev.	Changes Summary	Performed	Checked	Date
Performed by		Page		Revision
Checked by		3 / 6		
Date		13/04/2022		

THERMAL LIMIT CURVE



Three Phase Induction Motor - Squirrel Cage

Customer :

Product line : NEMA Premium Efficiency Three-Phase
Product code : 12727369
Catalog # : 01518OT3P254T-S

Performance : 200 V 60 Hz 4P

Rated current	: 42.8 A	Moment of inertia (J)	: 1.82 sq.ft.lb
LRC	: 6.7	Duty cycle	: Cont.(S1)
Rated torque	: 44.4 ft.lb	Insulation class	: F
Locked rotor torque	: 240 %	Service factor	: 1.15
Breakdown torque	: 300 %	Temperature rise	: 80 K
Rated speed	: 1775 rpm	Design	: B

Heating constant

Cooling constant

Rev.	Changes Summary	Performed	Checked	Date
Performed by				
Checked by			Page	Revision
Date	13/04/2022		4 / 6	

THERMAL LIMIT CURVE

Three Phase Induction Motor - Squirrel Cage



Customer : _____

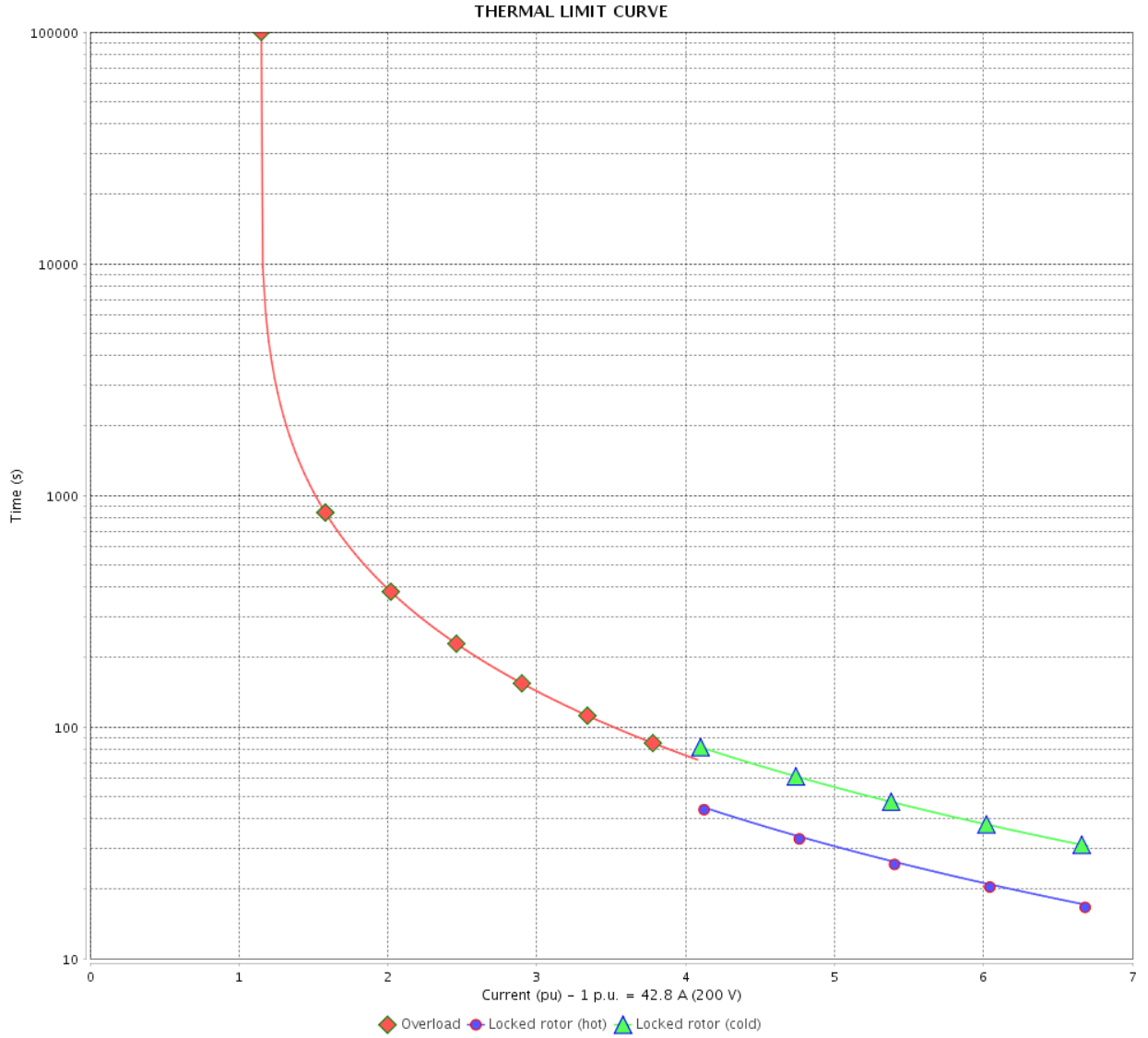

Rev.	Changes Summary	Performed	Checked	Date
Performed by		Page 5 / 6		Revision
Checked by				
Date				

VFD OPERATION CURVE

Three Phase Induction Motor - Squirrel Cage



Customer :

Product line : NEMA Premium Efficiency Three-Phase

Product code : 12727369

Catalog # : 01518OT3P254T-S

VFD OPERATION CURVE

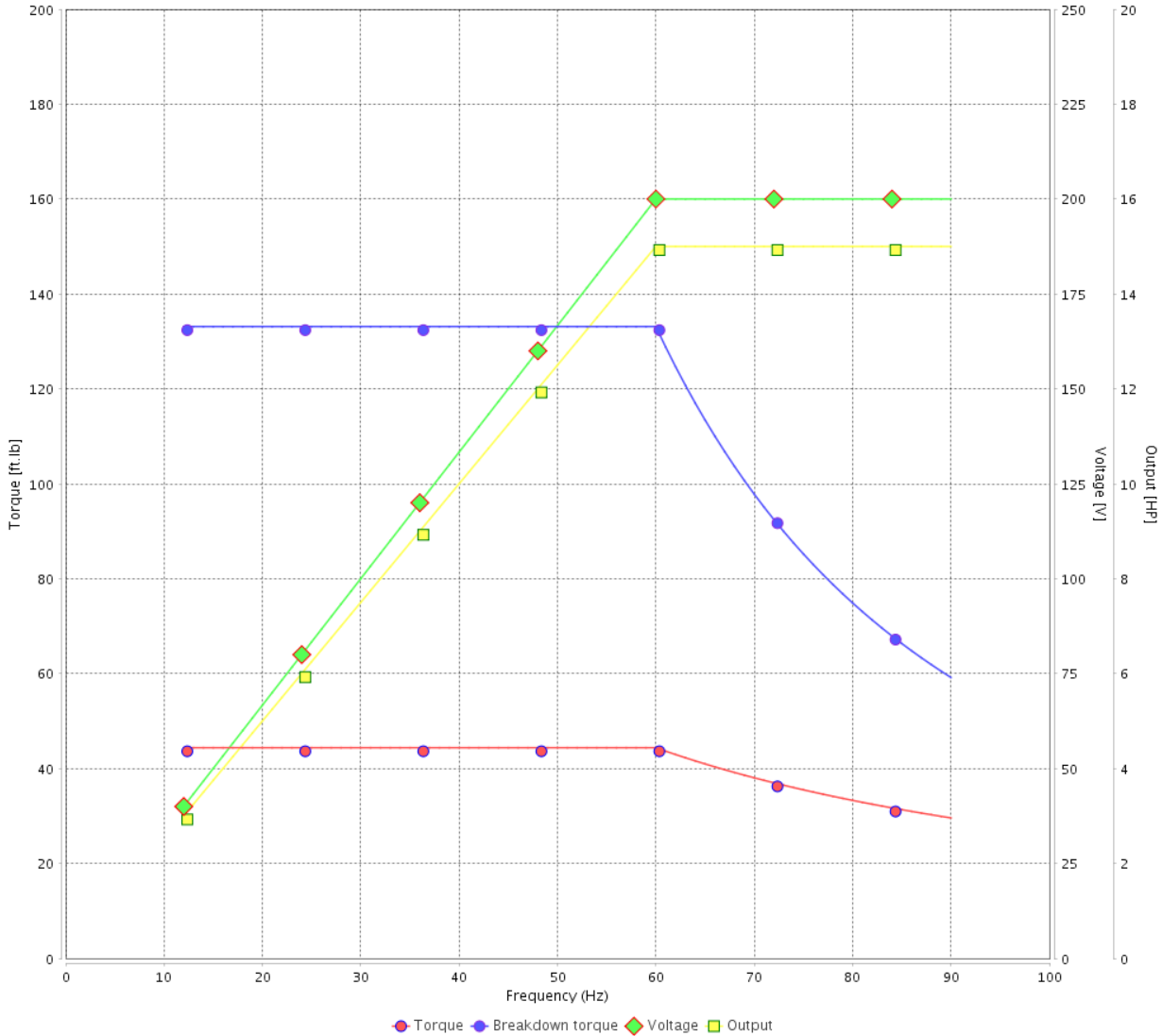

Performance : 200 V 60 Hz 4P

Rated current : 42.8 A
 LRC : 6.7
 Rated torque : 44.4 ft.lb
 Locked rotor torque : 240 %
 Breakdown torque : 300 %
 Rated speed : 1775 rpm

Moment of inertia (J) : 1.82 sq.ft.lb
 Duty cycle : Cont.(S1)
 Insulation class : F
 Service factor : 1.15
 Temperature rise : 80 K
 Design : B

Rev.	Changes Summary	Performed	Checked	Date
Performed by			Page 6 / 6	Revision
Checked by				
Date	13/04/2022			

A

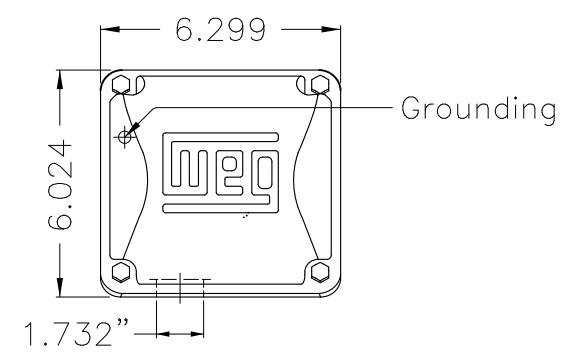

B

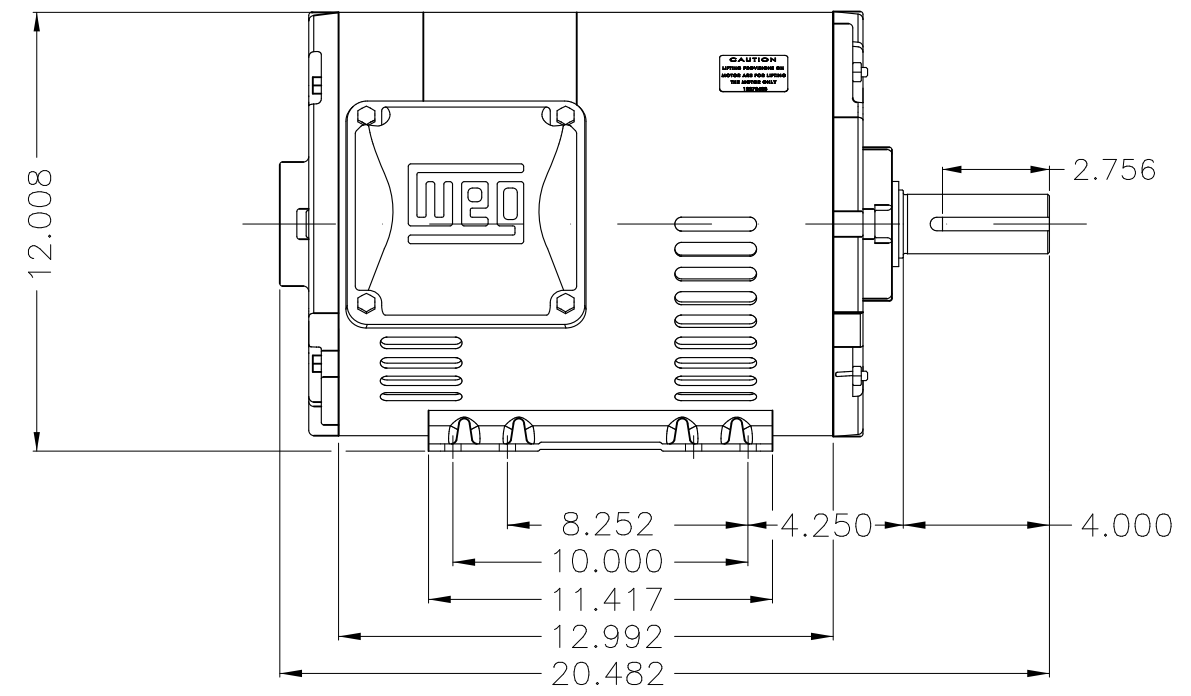
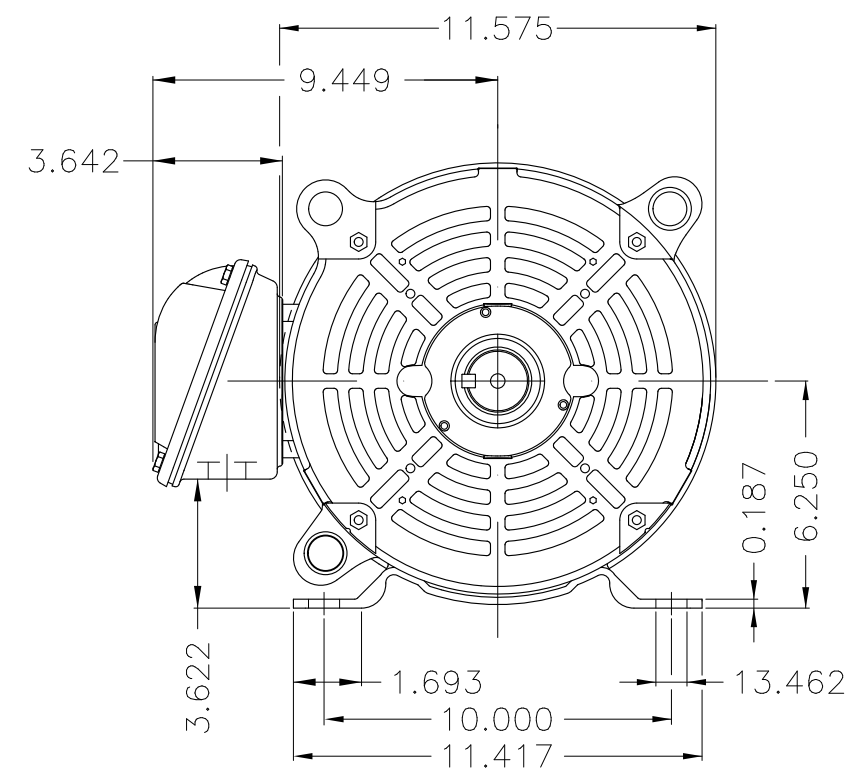

C

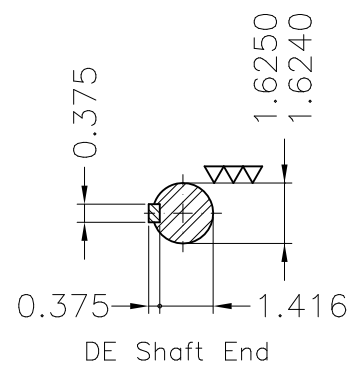

D

E

Color Munsell N 1 matte black
 Painting plan 207N
 Mounting F-1/B3R(D)

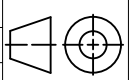
ECM	LOC	SUMMARY OF MODIFICATIONS	EXECUTED	CHECKED	RELEASED	DATE	VER
EXECUTED	PIRWBUSER	 THREE PH. MOTOR ROLLED STEEL PREM. EFF. FRAME 254/6T IP21 ODP					
CHECKED							
RELEASED							
REL DT.	WMO	Jaragua do Sul	Product Engineering	SHEET		1 / 1	

15 HP 04 Poles 60 Hz

A

PREVIEW
WDD



**NEMA**
Premium

MADE IN MEXICO

MAT: 12727369 CC029A
W01.T00IC0X0N
MODEL 01518OT3P254T-S
21APR2022 S/N:

PH 3	Hz 60	HP 15
FR 254/6T		KW 11
DUTY CONT.		V 200
ALT 1000 m.a.s.l.		A 42.8
INS CL F AT 80K		SFA 49.2
AMB 40°C	DES B	SF 1.15
ENCL ODP	CODE H	PF 0.80
		RPM 1775
		NEMA NOM. EFF 93.0%

Inverter duty motor For use on VPWM 1000:1 VT, 5:1 CT

DE 6309-Z-C3	ODE 6208-Z-C3	MOBIL POLYREX EM	20000h
--------------	---------------	------------------	--------

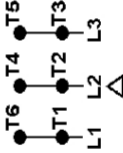

T1-BLU
 T2-WHT
 T3-ORG
 T4-YEL
 T5-BLK
 T6-GRY

INTERCHANGE ANY TWO LINE WIRES TO REVERSE THE ROTATION

WARNING: Motor must be grounded in accordance with local and national electrical codes to prevent serious electrical shocks. Disconnect power source before servicing unit.



AVERTISSEMENT: Le moteur doit être mis à la terre

conformément aux codes électriques locaux et nationaux afin d'éviter tout choc électrique grave. Déconnectez l'alimentation avant l'entretien de la machine.

