

DATA SHEET

Three Phase Induction Motor - Squirrel Cage



Customer :			
Product line	: NEMA Premium Efficiency Three-Phase	Product code :	12674694
		Catalog # :	01536OT3E215TC-S
Frame	: 213/5TC	Cooling method	: IC01 - ODP
Insulation class	: F	Mounting	: F-1
Duty cycle	: Cont.(S1)	Rotation ¹	: Both (CW and CCW)
Ambient temperature	: -20°C to +40°C	Starting method	: Direct On Line
Altitude	: 1000 m.a.s.l.	Approx. weight ²	: 143 lb
Design	: B	Moment of inertia (J)	: 0.5512 sq.ft.lb
Output [HP]	15	15	15
Poles	2	2	2
Frequency [Hz]	60	50	50
Rated voltage [V]	230/460	190/380	220/415
Rated current [A]	34.4/17.2	42.0/21.0	37.9/20.1
L. R. Amperes [A]	234/117	227/113	227/121
LRC [A]	6.8x(Code G)	5.4x(Code E)	6.0x(Code F)
No load current [A]	12.3/6.17	12.1/6.04	12.8/6.81
Rated speed [RPM]	3535	2905	2910
Slip [%]	1.81	3.17	3.00
Rated torque [ft.lb]	22.3	27.1	27.1
Locked rotor torque [%]	210	160	180
Breakdown torque [%]	280	200	229
Service factor	1.15	1.00	1.00
Temperature rise	80 K	105 K	80 K
Locked rotor time	14s (cold) 8s (hot)	0s (cold) 0s (hot)	0s (cold) 0s (hot)
Noise level ²	66.0 dB(A)	64.0 dB(A)	64.0 dB(A)
Efficiency (%)	25%	90.1	91.3
	50%	90.2	90.2
	75%	90.2	88.9
	100%	90.2	87.6
Power Factor	25%	0.50	0.57
	50%	0.77	0.83
	75%	0.86	0.89
	100%	0.89	0.91
Bearing type	: <u>Drive end</u> 6208 ZZ <u>Non drive end</u> 6206 ZZ	Foundation loads	
Sealing	: Without Without Bearing Seal Bearing Seal	Max. traction	: 280 lb
		Max. compression	: 422 lb
Lubrication interval	: - -		
Lubricant amount	: - -		
Lubricant type	: Mobil Polyrex EM		
Notes USABLE @208V 38.0A SF 1.00 SFA 38.0A			
This revision replaces and cancel the previous one, which must be eliminated. (1) Looking the motor from the shaft end. (2) Measured at 1m and with tolerance of +3dB(A). (3) Approximate weight subject to changes after manufacturing process. (4) At 100% of full load.		These are average values based on tests with sinusoidal power supply, subject to the tolerances stipulated in NEMA MG-1.	
Rev.	Changes Summary	Performed	Checked
			Date
Performed by			
Checked by			Page
Date	13/04/2022		Revision
			1 /

TORQUE AND CURRENT VS SPEED CURVE

Three Phase Induction Motor - Squirrel Cage



Customer :

Product line : NEMA Premium Efficiency Three-Phase

Product code : 12674694

Catalog # : 01536OT3E215TC-S

TORQUE AND CURRENT VS SPEED CURVE

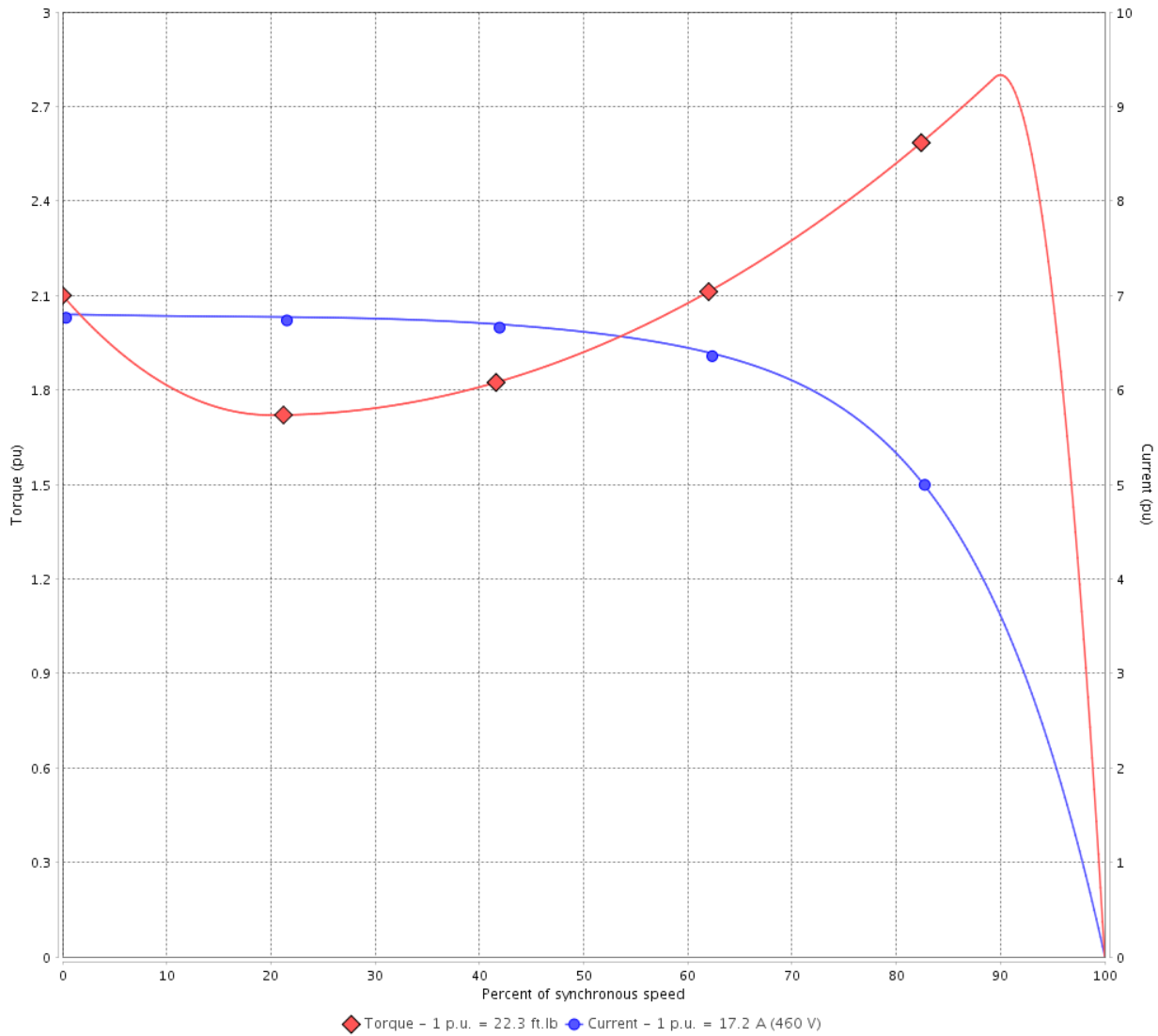

Performance : 230/460 V 60 Hz 2P

Rated current	: 34.4/17.2 A	Moment of inertia (J)	: 0.5512 sq.ft.lb
LRC	: 6.8	Duty cycle	: Cont.(S1)
Rated torque	: 22.3 ft.lb	Insulation class	: F
Locked rotor torque	: 210 %	Service factor	: 1.15
Breakdown torque	: 280 %	Temperature rise	: 80 K
Rated speed	: 3535 rpm	Design	: B

Locked rotor time : 14s (cold) 8s (hot)

Rev.	Changes Summary	Performed	Checked	Date
Performed by		Page		Revision
Checked by		2 /		
Date	13/04/2022			

TORQUE AND CURRENT VS SPEED CURVE



Three Phase Induction Motor - Squirrel Cage

Customer :

Product line : NEMA Premium Efficiency Three-Phase

Product code : 12674694

Catalog # : 01536OT3E215TC-S

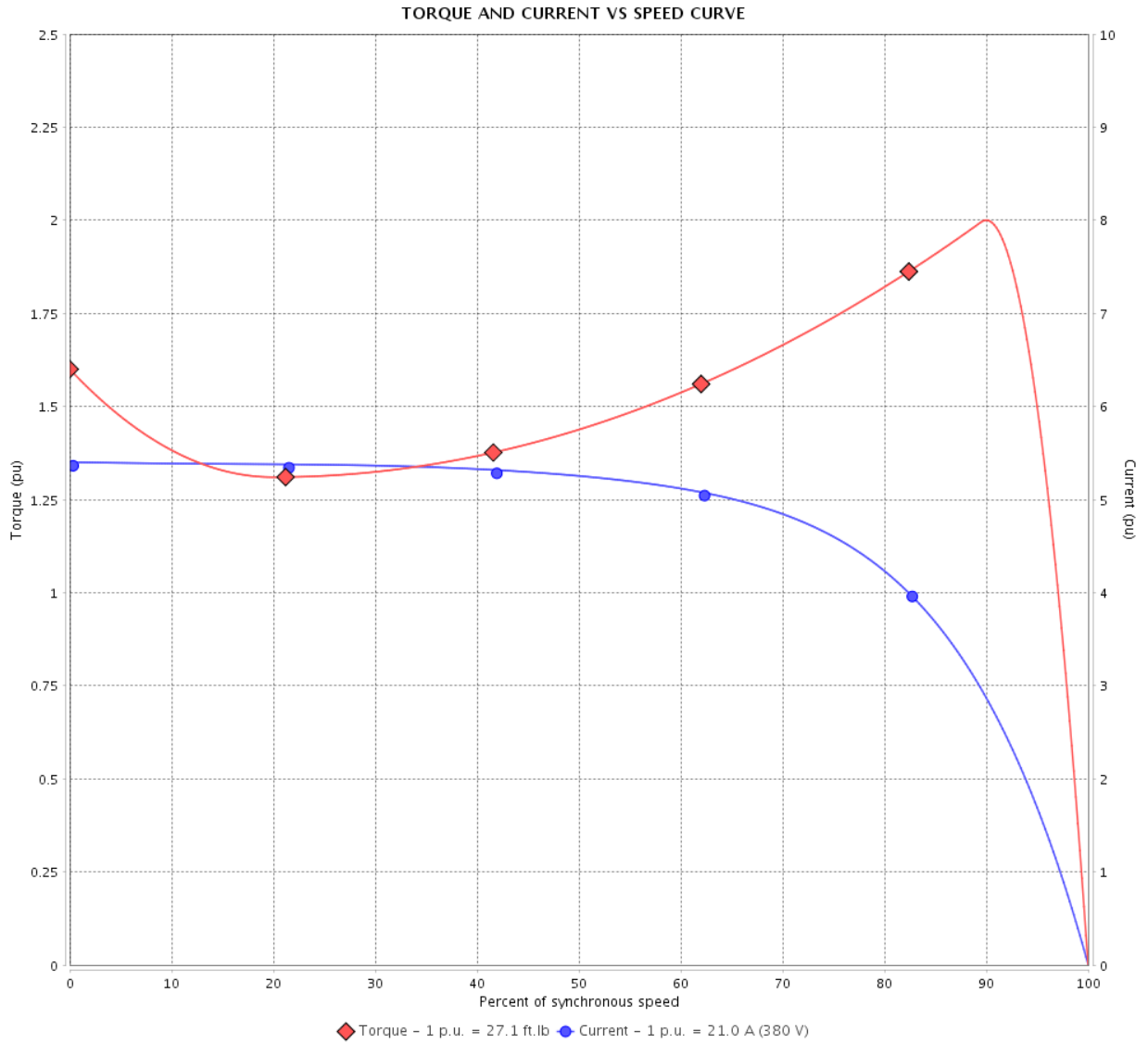

Performance : 190/380 V 50 Hz 2P

Rated current : 42.0/21.0 A
 LRC : 5.4
 Rated torque : 27.1 ft.lb
 Locked rotor torque : 160 %
 Breakdown torque : 200 %
 Rated speed : 2905 rpm

Moment of inertia (J) : 0.5512 sq.ft.lb
 Duty cycle : Cont.(S1)
 Insulation class : F
 Service factor : 1.00
 Temperature rise : 105 K
 Design : B

Locked rotor time : 0s (cold) 0s (hot)

Rev.	Changes Summary	Performed	Checked	Date
Performed by			Page 3 /	Revision
Checked by				
Date	13/04/2022			

TORQUE AND CURRENT VS SPEED CURVE

Three Phase Induction Motor - Squirrel Cage



Customer :

Product line : NEMA Premium Efficiency Three-Phase

Product code : 12674694

Catalog # : 015360T3E215TC-S

TORQUE AND CURRENT VS SPEED CURVE

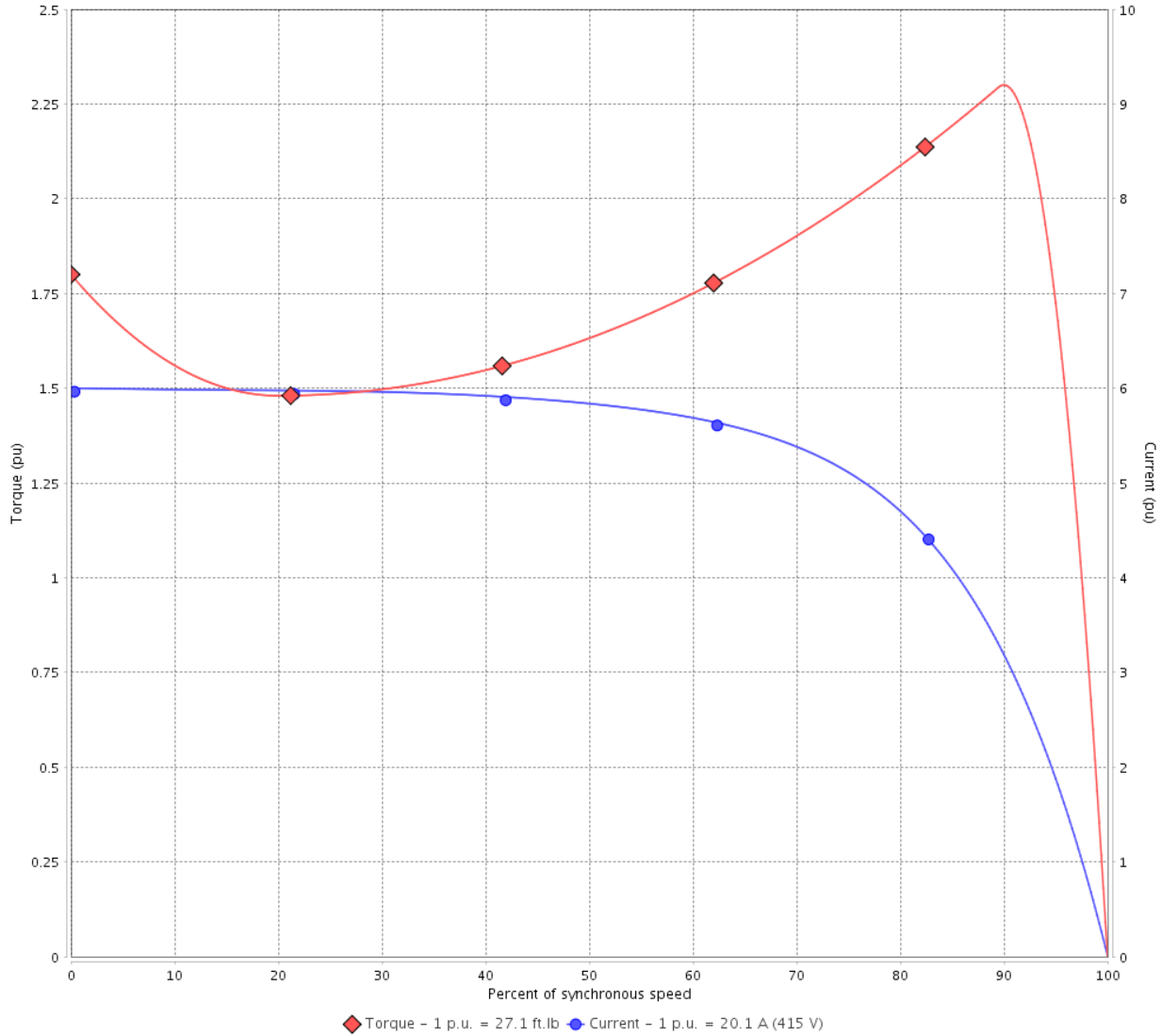

Performance : 220/415 V 50 Hz 2P

Rated current	: 37.9/20.1 A	Moment of inertia (J)	: 0.5512 sq.ft.lb
LRC	: 6.0	Duty cycle	: Cont.(S1)
Rated torque	: 27.1 ft.lb	Insulation class	: F
Locked rotor torque	: 180 %	Service factor	: 1.00
Breakdown torque	: 229 %	Temperature rise	: 80 K
Rated speed	: 2910 rpm	Design	: B

Locked rotor time : 0s (cold) 0s (hot)

Rev.	Changes Summary	Performed	Checked	Date
Performed by			Page 4 /	Revision
Checked by				
Date	13/04/2022			

LOAD PERFORMANCE CURVE

Three Phase Induction Motor - Squirrel Cage



Customer :

Product line : NEMA Premium Efficiency Three-Phase

Product code : 12674694

Catalog # : 01536OT3E215TC-S

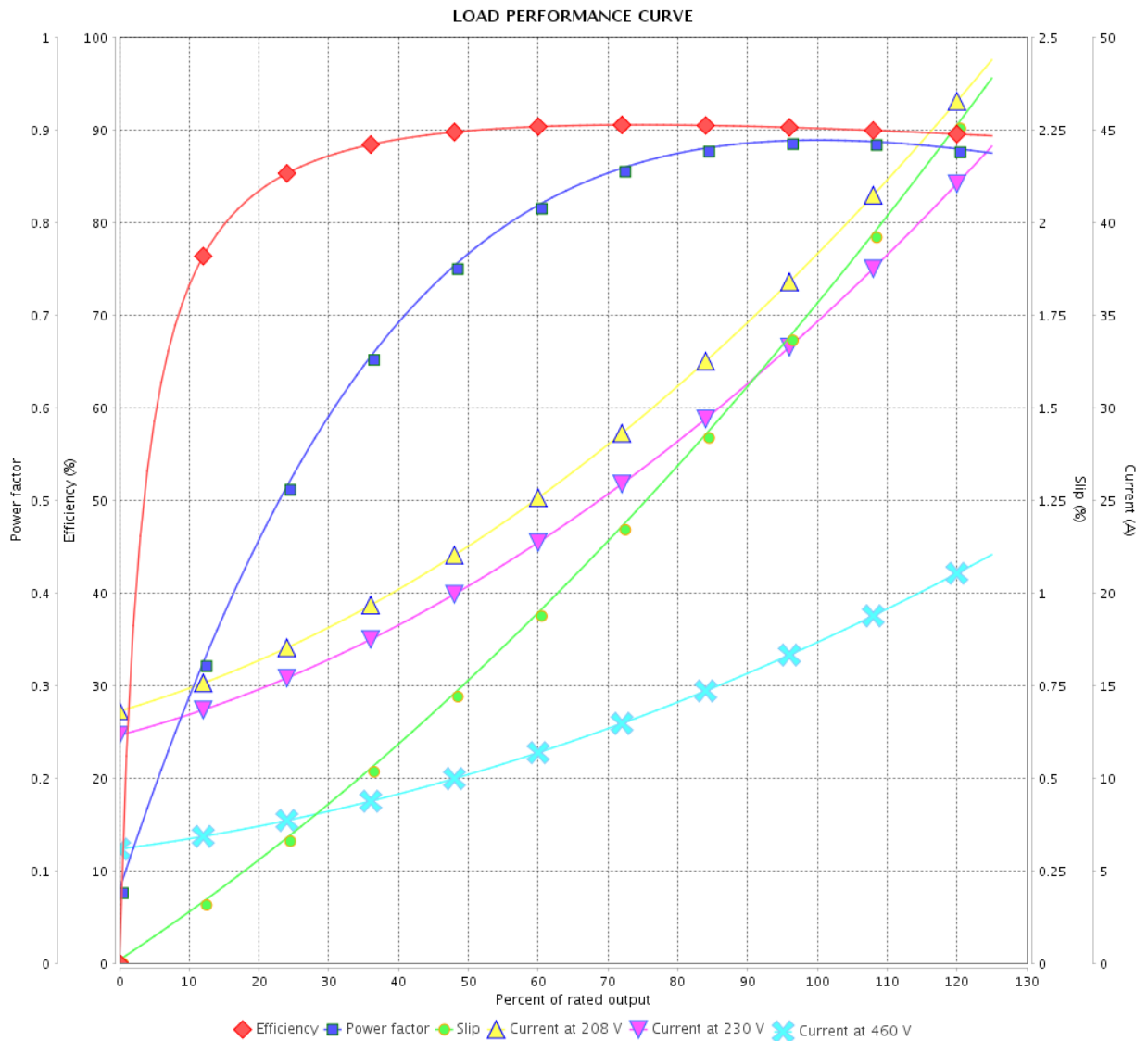

Performance : 230/460 V 60 Hz 2P

Rated current : 34.4/17.2 A
 LRC : 6.8
 Rated torque : 22.3 ft.lb
 Locked rotor torque : 210 %
 Breakdown torque : 280 %
 Rated speed : 3535 rpm

Moment of inertia (J) : 0.5512 sq.ft.lb
 Duty cycle : Cont.(S1)
 Insulation class : F
 Service factor : 1.15
 Temperature rise : 80 K
 Design : B

Rev.	Changes Summary	Performed	Checked	Date
Performed by		Page		Revision
Checked by		5 /		
Date		13/04/2022		

LOAD PERFORMANCE CURVE

Three Phase Induction Motor - Squirrel Cage



Customer :

Product line : NEMA Premium Efficiency Three-Phase

Product code : 12674694

Catalog # : 01536OT3E215TC-S

LOAD PERFORMANCE CURVE

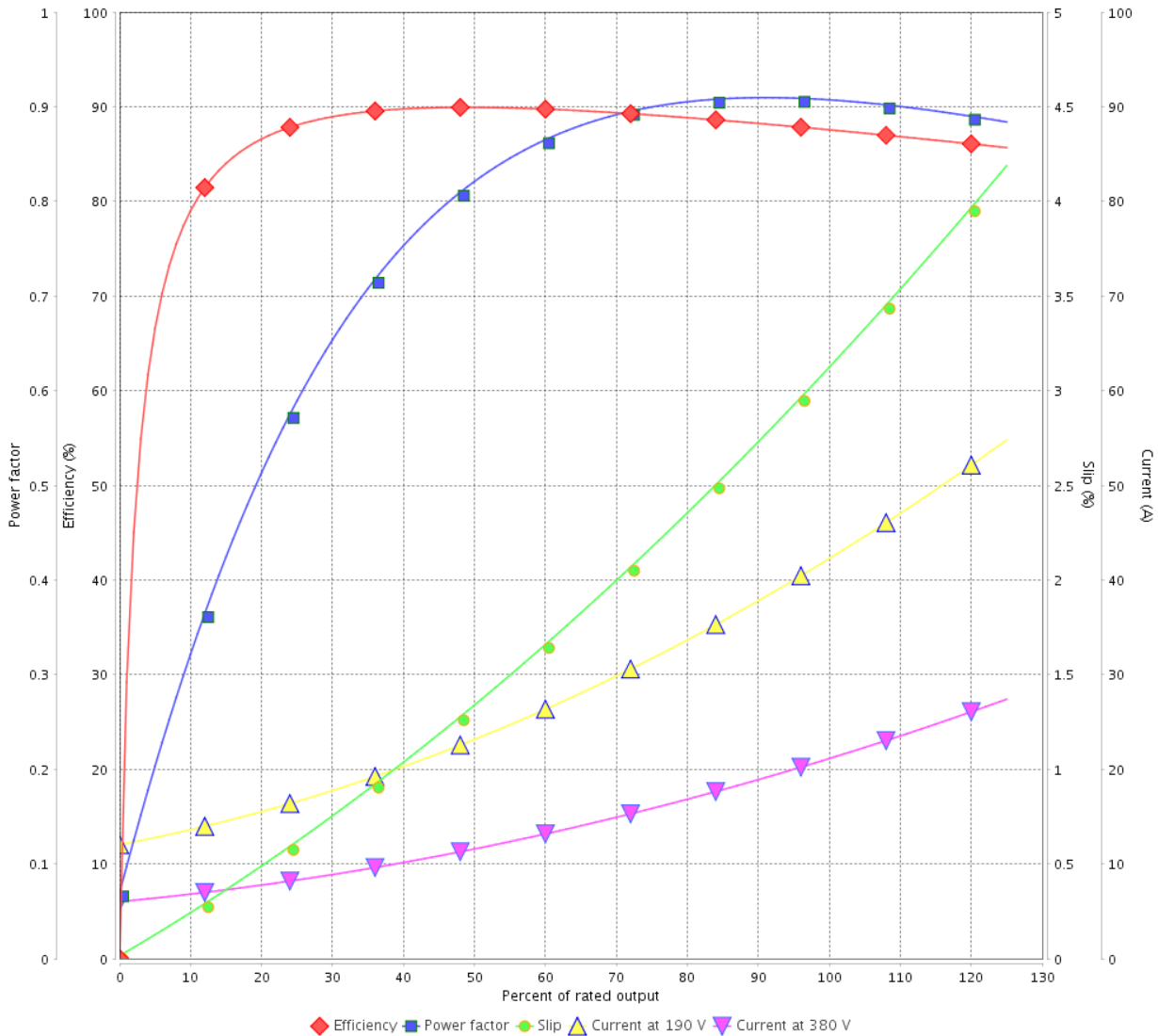

Performance : 190/380 V 50 Hz 2P

Rated current : 42.0/21.0 A
 LRC : 5.4
 Rated torque : 27.1 ft.lb
 Locked rotor torque : 160 %
 Breakdown torque : 200 %
 Rated speed : 2905 rpm

Moment of inertia (J) : 0.5512 sq.ft.lb
 Duty cycle : Cont.(S1)
 Insulation class : F
 Service factor : 1.00
 Temperature rise : 105 K
 Design : B

Rev.	Changes Summary	Performed	Checked	Date
Performed by			Page	Revision
Checked by			6 /	
Date	13/04/2022			

LOAD PERFORMANCE CURVE

Three Phase Induction Motor - Squirrel Cage



Customer :

Product line : NEMA Premium Efficiency Three-Phase

Product code : 12674694

Catalog # : 01536OT3E215TC-S

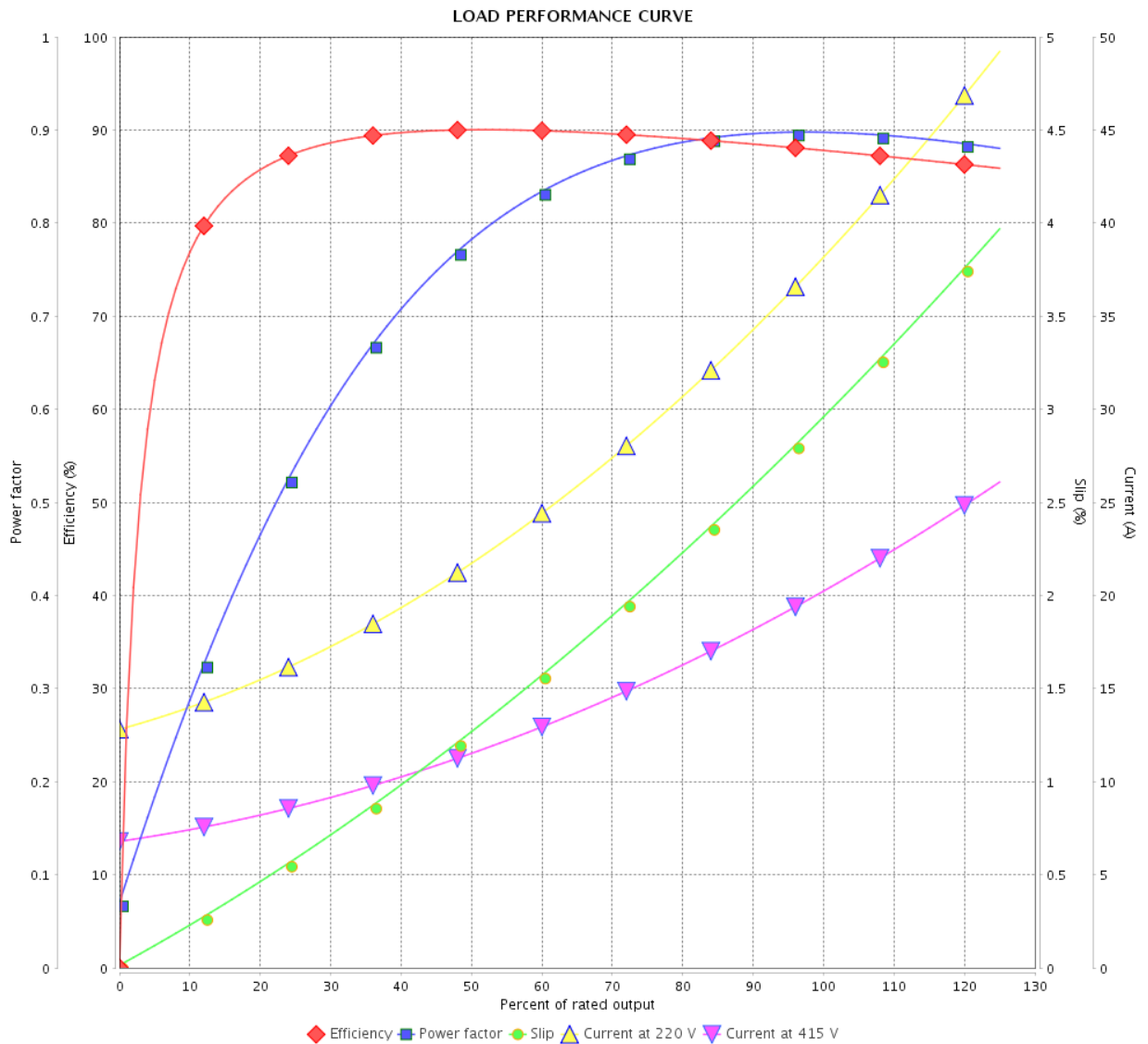

Performance : 220/415 V 50 Hz 2P

Rated current : 37.9/20.1 A
 LRC : 6.0
 Rated torque : 27.1 ft.lb
 Locked rotor torque : 180 %
 Breakdown torque : 229 %
 Rated speed : 2910 rpm

Moment of inertia (J) : 0.5512 sq.ft.lb
 Duty cycle : Cont.(S1)
 Insulation class : F
 Service factor : 1.00
 Temperature rise : 80 K
 Design : B

Rev.	Changes Summary	Performed	Checked	Date
Performed by		Page		Revision
Checked by		7 /		
Date		13/04/2022		

THERMAL LIMIT CURVE

Three Phase Induction Motor - Squirrel Cage



Customer :

Product line : NEMA Premium Efficiency Three-Phase
Product code : 12674694
Catalog # : 01536OT3E215TC-S

Performance : 230/460 V 60 Hz 2P

Rated current	: 34.4/17.2 A	Moment of inertia (J)	: 0.5512 sq.ft.lb
LRC	: 6.8	Duty cycle	: Cont.(S1)
Rated torque	: 22.3 ft.lb	Insulation class	: F
Locked rotor torque	: 210 %	Service factor	: 1.15
Breakdown torque	: 280 %	Temperature rise	: 80 K
Rated speed	: 3535 rpm	Design	: B

Heating constant

Cooling constant

Rev.	Changes Summary	Performed	Checked	Date
Performed by				
Checked by			Page	Revision
Date	13/04/2022		8 /	

THERMAL LIMIT CURVE

Three Phase Induction Motor - Squirrel Cage



Customer : _____

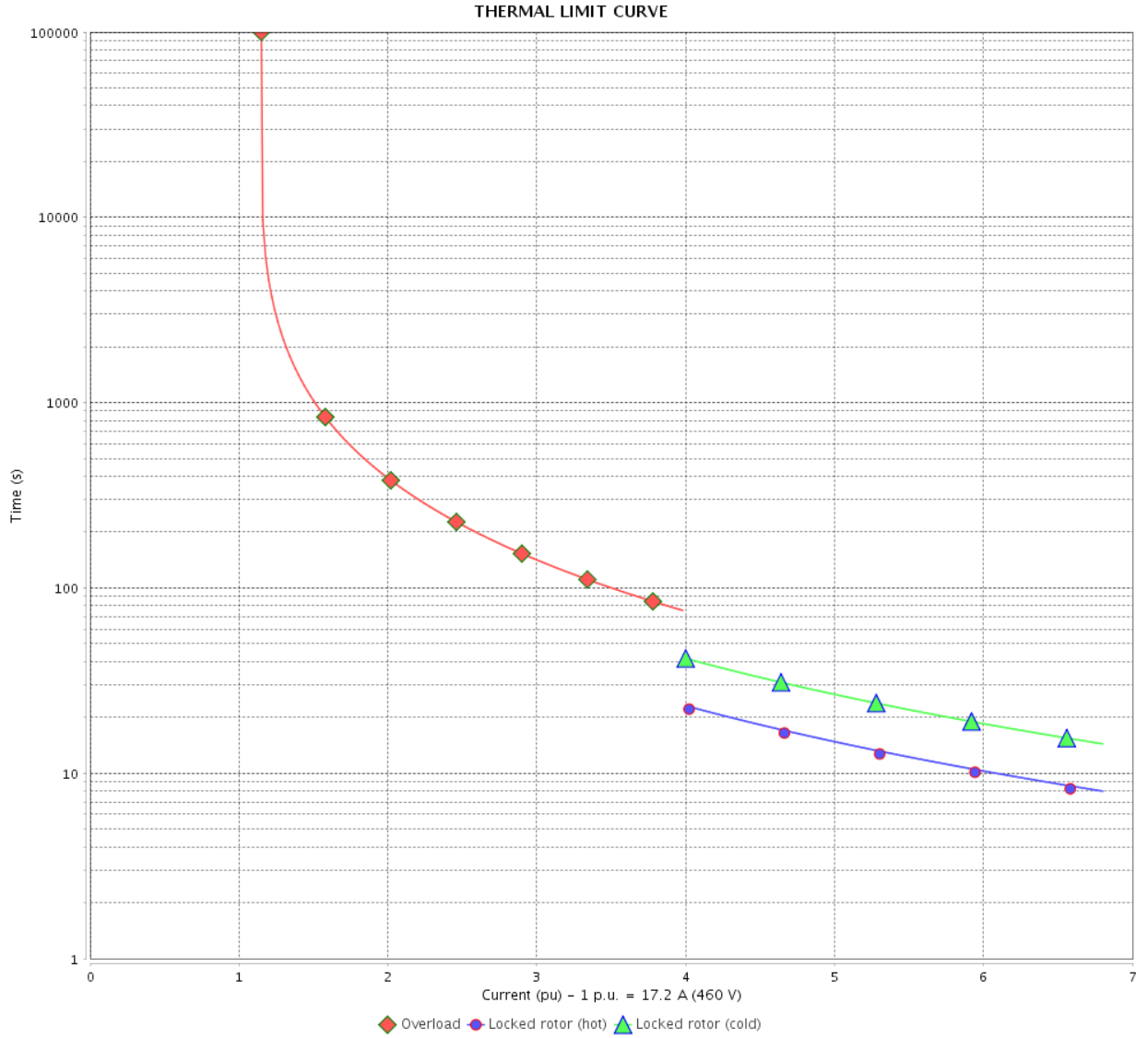

Rev.	Changes Summary	Performed	Checked	Date
Performed by		Page		Revision
Checked by		9 /		
Date		13/04/2022		

THERMAL LIMIT CURVE



Three Phase Induction Motor - Squirrel Cage

Customer :

Product line : NEMA Premium Efficiency Three-Phase
Product code : 12674694
Catalog # : 01536OT3E215TC-S

Performance : 190/380 V 50 Hz 2P

Rated current	: 42.0/21.0 A	Moment of inertia (J)	: 0.5512 sq.ft.lb
LRC	: 5.4	Duty cycle	: Cont.(S1)
Rated torque	: 27.1 ft.lb	Insulation class	: F
Locked rotor torque	: 160 %	Service factor	: 1.00
Breakdown torque	: 200 %	Temperature rise	: 105 K
Rated speed	: 2905 rpm	Design	: B

Heating constant

Cooling constant

Rev.	Changes Summary	Performed	Checked	Date
Performed by				
Checked by			Page	Revision
Date	13/04/2022		10 /	

THERMAL LIMIT CURVE

Three Phase Induction Motor - Squirrel Cage



Customer : _____

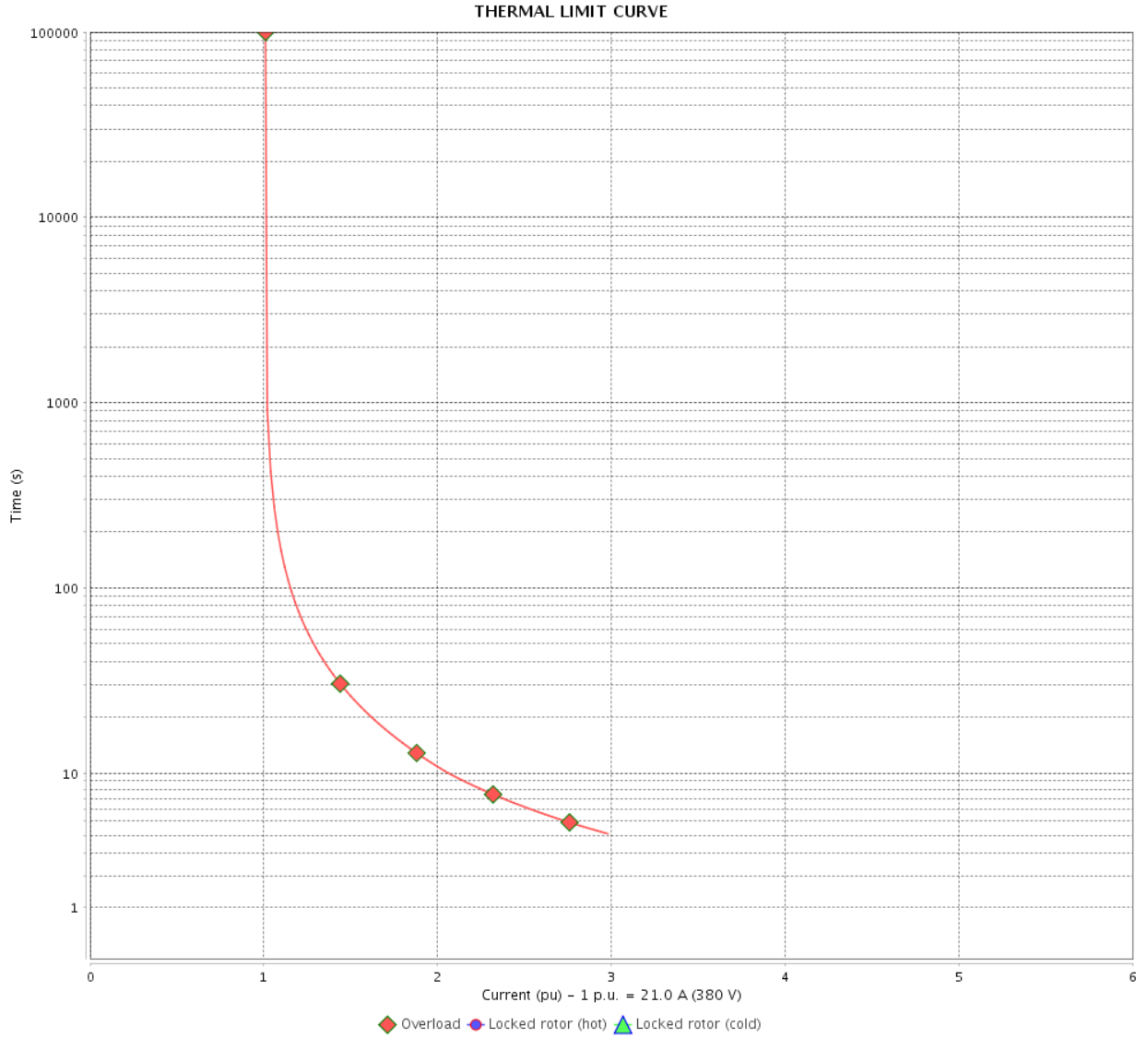

Rev.	Changes Summary	Performed	Checked	Date
Performed by		Page		Revision
Checked by		11 /		
Date		13/04/2022		

THERMAL LIMIT CURVE

Three Phase Induction Motor - Squirrel Cage



Customer :

Product line : NEMA Premium Efficiency Three-Phase
Product code : 12674694
Catalog # : 01536OT3E215TC-S

Performance : 220/415 V 50 Hz 2P

Rated current	: 37.9/20.1 A	Moment of inertia (J)	: 0.5512 sq.ft.lb
LRC	: 6.0	Duty cycle	: Cont.(S1)
Rated torque	: 27.1 ft.lb	Insulation class	: F
Locked rotor torque	: 180 %	Service factor	: 1.00
Breakdown torque	: 229 %	Temperature rise	: 80 K
Rated speed	: 2910 rpm	Design	: B

Heating constant

Cooling constant

Rev.	Changes Summary	Performed	Checked	Date
Performed by				
Checked by			Page	Revision
Date	13/04/2022		12 /	

THERMAL LIMIT CURVE

Three Phase Induction Motor - Squirrel Cage



Customer : _____

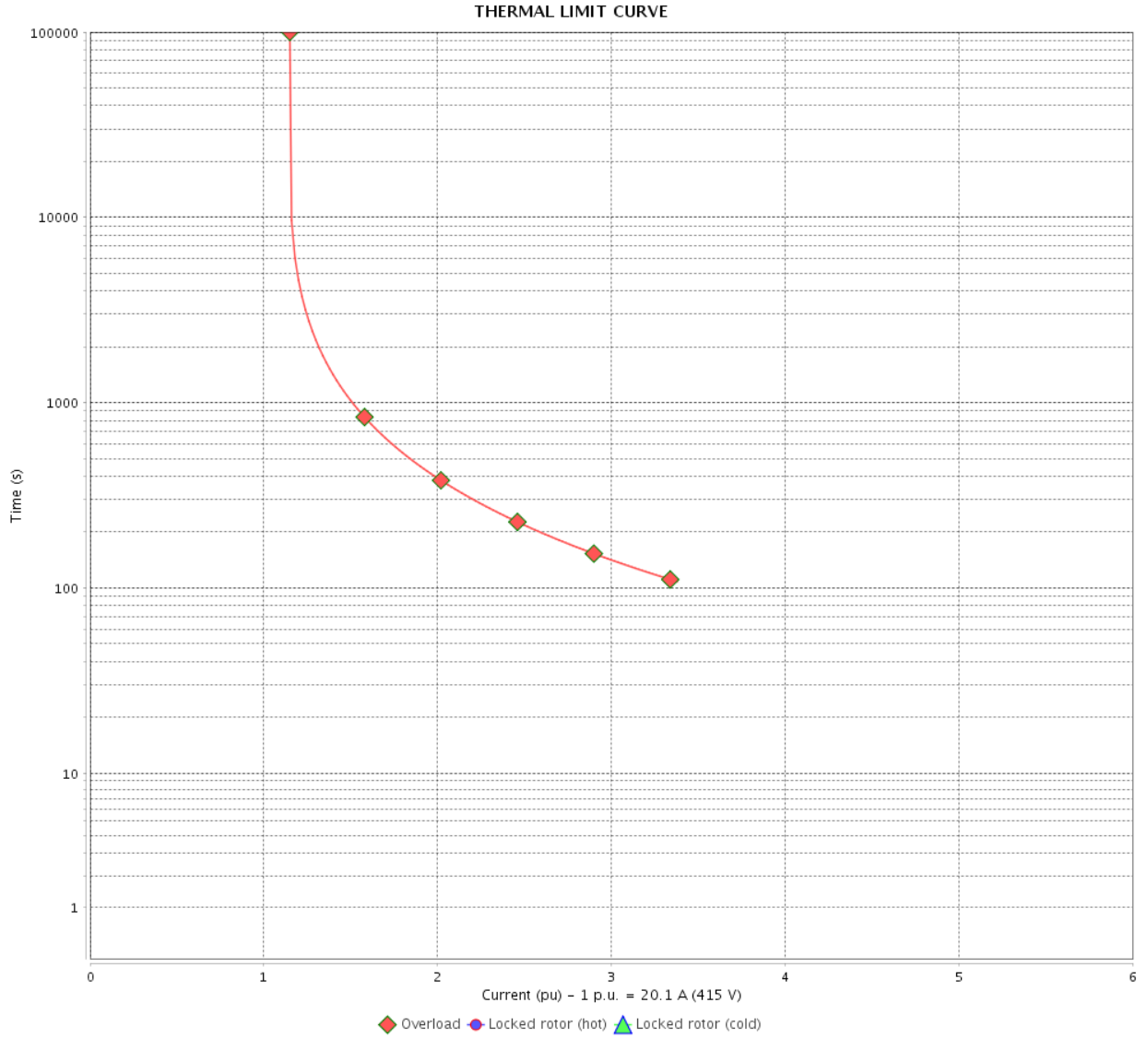

Rev.	Changes Summary	Performed	Checked	Date
Performed by		Page		Revision
Checked by		13 /		
Date		13/04/2022		

VFD OPERATION CURVE

Three Phase Induction Motor - Squirrel Cage



Customer :

Product line : NEMA Premium Efficiency Three-Phase

Product code : 12674694

Catalog # : 01536OT3E215TC-S

VFD OPERATION CURVE

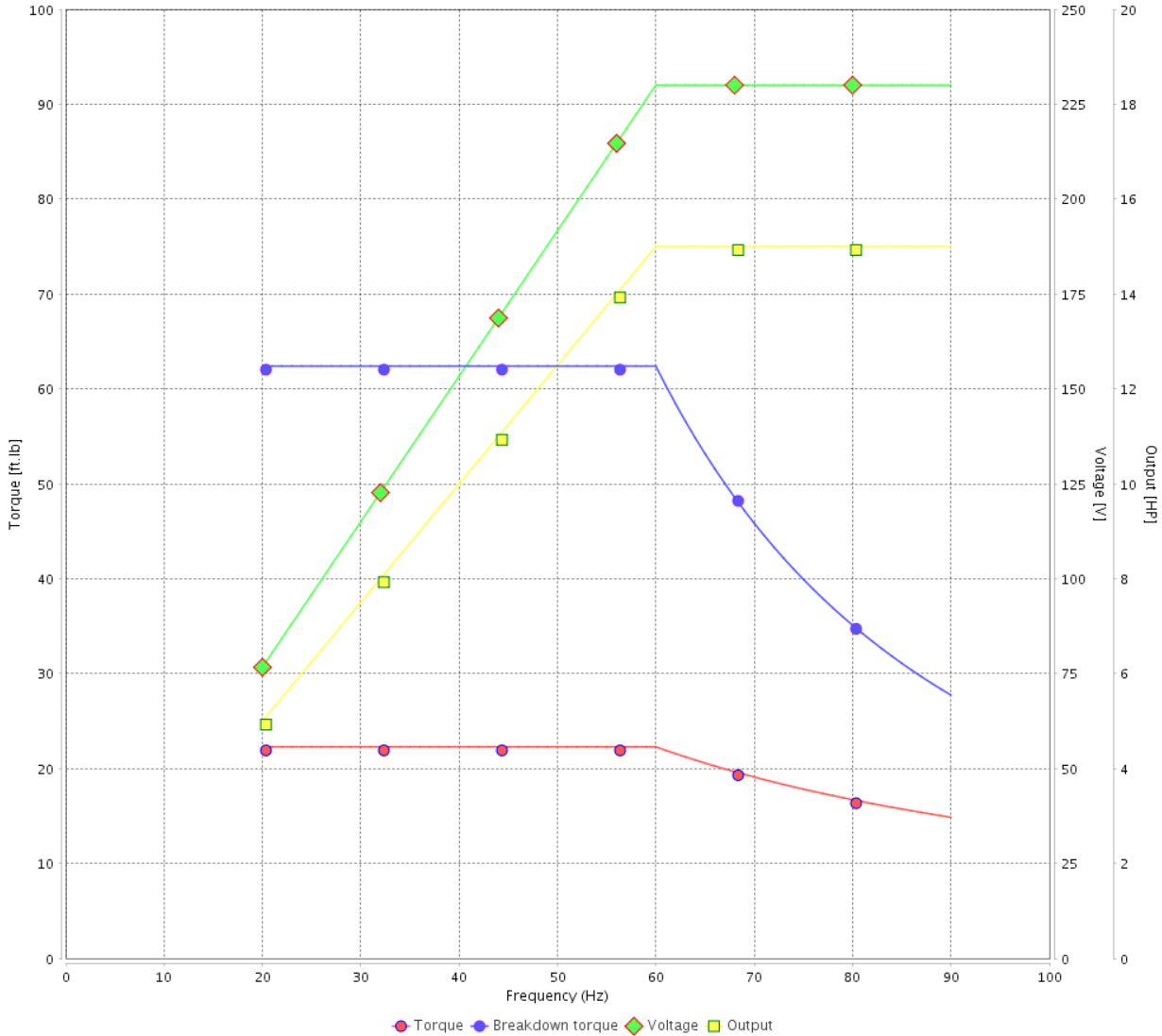

Performance : 230/460 V 60 Hz 2P

Rated current : 34.4/17.2 A
 LRC : 6.8
 Rated torque : 22.3 ft.lb
 Locked rotor torque : 210 %
 Breakdown torque : 280 %
 Rated speed : 3535 rpm

Moment of inertia (J) : 0.5512 sq.ft.lb
 Duty cycle : Cont.(S1)
 Insulation class : F
 Service factor : 1.15
 Temperature rise : 80 K
 Design : B

Rev.	Changes Summary	Performed	Checked	Date
Performed by			Page 14 /	Revision
Checked by				
Date	13/04/2022			

1 2 3 4 5 6

A

B

C

D

E

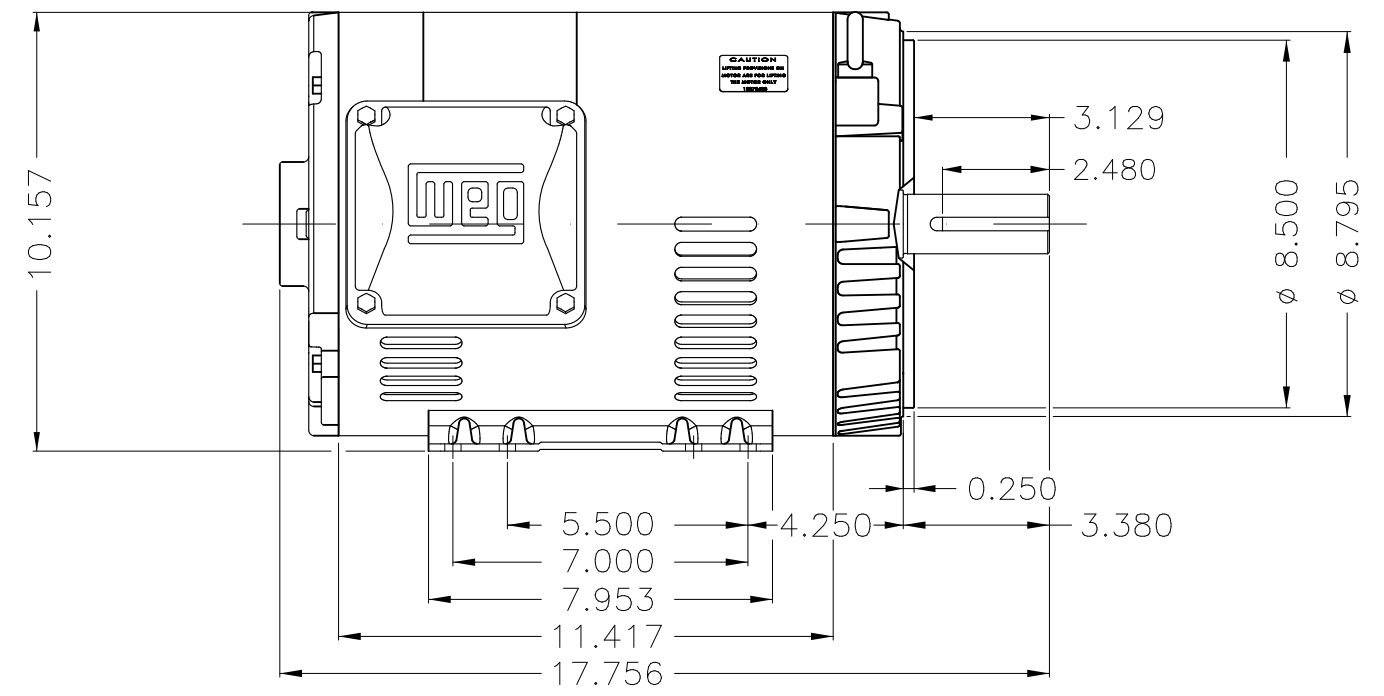
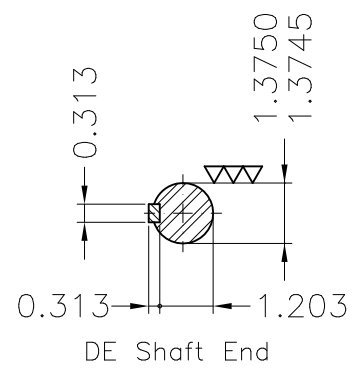
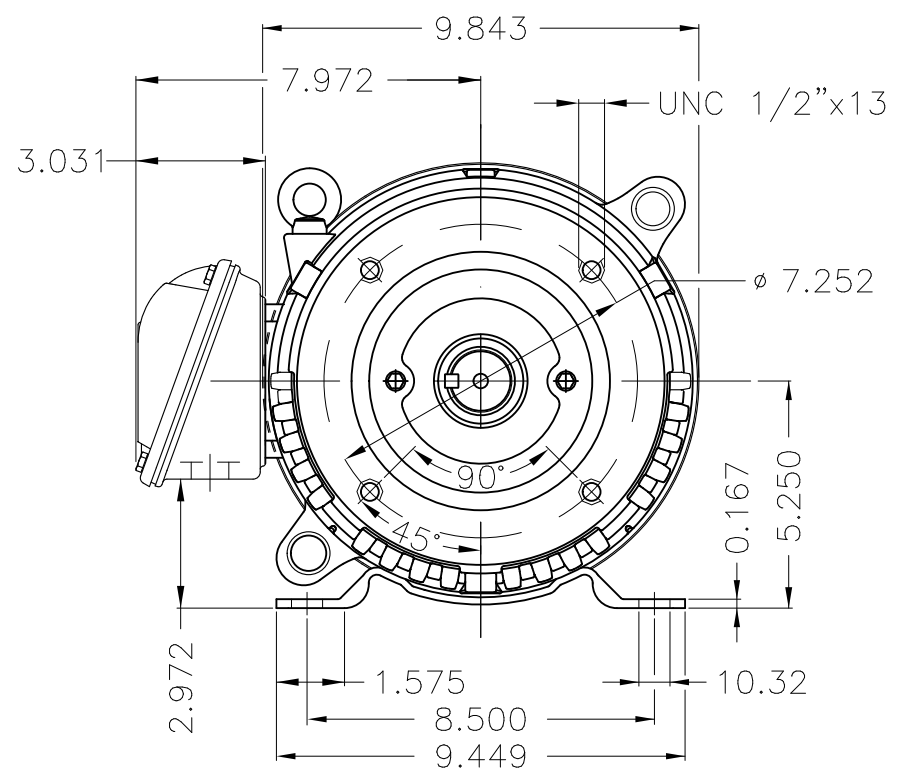
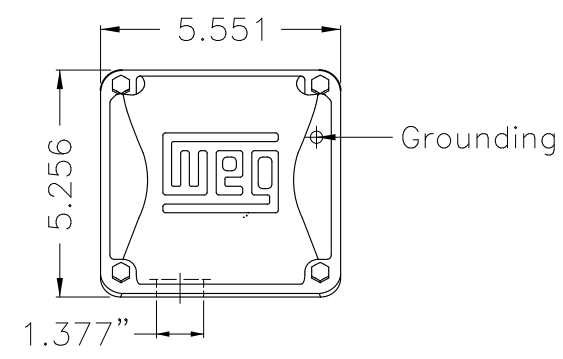

Color Munsell N 1 matte black
 Painting plan 207N
 Mounting F-1/B34R(D)

ECM	LOC	SUMMARY OF MODIFICATIONS	EXECUTED	CHECKED	RELEASED	DATE	VER
EXECUTED	PIRWBUSER	THREE PH. MOTOR ROLLED STEEL PREM. EFF. FRAME 213/5TC IP21 ODP					
CHECKED							
RELEASED							
REL DT.	WMO	Jaragua do Sul	Product Engineering	SHEET	1 / 1		

15 HP 02 Poles 60 Hz

A

PREVIEW
WDD



Dimensions in inches XME A3



NEMA
Premium

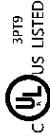

3PT9



Energy Verified

MADE IN MEXICO

MAT: 12674694 CC029A

W01.T00IC0X0N

MODEL 01536OT3E215TC-S

23MAR2022 S/N:

PH 3	Hz 60	HP 15
FR 213/5TC		KW 11
DUTY CONT.		V 230/460
ALT 1000 m.a.s.l.		A 34.4/17.2
INS CL F AT 80K		SFA 39.6/19.8
AMB 40°C	DES B	SF 1.15
ENCL ODP	CODE G	PF 0.89
USABLE @ 208V 38.0A		RPM 3535
SF1.00		NEMA NOM. EFF 90.2%

ALTERNATE RATING: 15HP 50Hz 190-220/380-415V SF1.00
42.0-36.8/21.0-19.5A 2905RPM EFF 87.6% (IE1) IEC 60034-1

Inverter duty motor For 80Hz use on VPWM 1000:1 VT, 3:1 CT

DE 6208-ZZ	ODE 6206-ZZ	MOBIL POLYREX EM
-------------------	--------------------	-------------------------



T1-BLU T2-WHT
 T3-ORG T4-YEL
 T5-BLK T6-GRY
 T7-PNK T8-RED
 T9-BRK RED

INTERCHANGE ANY TWO LINE WIRES TO REVERSE THE ROTATION

WARNING: Motor must be grounded in accordance with local and national electrical codes to prevent serious electrical shocks. Disconnect power source before servicing unit.



AVERTISSEMENT: Le moteur doit être mis à la terre

conformément aux codes électriques locaux et nationaux afin d'éviter tout choc électrique grave. Déconnectez l'alimentation avant l'entretien de la machine.

