

DATA SHEET



Three Phase Induction Motor - Squirrel Cage

Customer :																			
Product line	: NEMA Premium Efficiency Three-Phase																		
Product code :	12385116																		
Catalog # :	01536ST3HIE254T-W22																		
Frame : 254/6T Output : 15 HP (11 kW) Poles : 2 Frequency : 60 Hz Rated voltage : 575 V Rated current : 13.8 A L. R. Amperes : 92.2 A LRC : 6.7x(Code G) No load current : 4.24 A Rated speed : 3530 rpm Slip : 1.94 % Rated torque : 22.3 ft.lb Locked rotor torque : 220 % Breakdown torque : 270 % Insulation class : F Service factor : 1.25 Moment of inertia (J) : 1.26 sq.ft.lb Design : B	Locked rotor time : 45s (cold) 25s (hot) Temperature rise : 80 K Duty cycle : Cont.(S1) Ambient temperature : -20°C to +40°C Altitude : 1000 m.a.s.l. Protection degree : IP55 Cooling method : IC411 - TEFC Mounting : F-1 Rotation ¹ : Both (CW and CCW) Noise level ² : 72.0 dB(A) Starting method : Direct On Line Approx. weight ³ : 280 lb																		
Output	25% 50% 75% 100%																		
Efficiency (%)	89.2 89.5 91.0 91.0																		
Power Factor	0.53 0.77 0.85 0.88																		
Foundation loads																			
Max. traction : 149 lb																			
Max. compression : 428 lb																			
	<table border="0"> <tr> <td></td> <td style="text-align: center;"><u>Drive end</u></td> <td style="text-align: center;"><u>Non drive end</u></td> </tr> <tr> <td>Bearing type :</td> <td style="text-align: center;">6309 C3</td> <td style="text-align: center;">6209 C3</td> </tr> <tr> <td>Sealing :</td> <td style="text-align: center;">Inpro/Seal</td> <td style="text-align: center;">Inpro/Seal</td> </tr> <tr> <td>Lubrication interval :</td> <td style="text-align: center;">19000 h</td> <td style="text-align: center;">20000 h</td> </tr> <tr> <td>Lubricant amount :</td> <td style="text-align: center;">13 g</td> <td style="text-align: center;">9 g</td> </tr> <tr> <td>Lubricant type :</td> <td colspan="2" style="text-align: center;">Mobil Polyrex EM</td> </tr> </table>		<u>Drive end</u>	<u>Non drive end</u>	Bearing type :	6309 C3	6209 C3	Sealing :	Inpro/Seal	Inpro/Seal	Lubrication interval :	19000 h	20000 h	Lubricant amount :	13 g	9 g	Lubricant type :	Mobil Polyrex EM	
	<u>Drive end</u>	<u>Non drive end</u>																	
Bearing type :	6309 C3	6209 C3																	
Sealing :	Inpro/Seal	Inpro/Seal																	
Lubrication interval :	19000 h	20000 h																	
Lubricant amount :	13 g	9 g																	
Lubricant type :	Mobil Polyrex EM																		
Notes																			
This revision replaces and cancel the previous one, which must be eliminated. (1) Looking the motor from the shaft end. (2) Measured at 1m and with tolerance of +3dB(A). (3) Approximate weight subject to changes after manufacturing process. (4) At 100% of full load.																			
These are average values based on tests with sinusoidal power supply, subject to the tolerances stipulated in NEMA MG-1.																			
Rev.	Changes Summary	Performed	Checked	Date															
Performed by																			
Checked by			Page	Revision															
Date	13/04/2022		1 / 6																

TORQUE AND CURRENT VS SPEED CURVE

Three Phase Induction Motor - Squirrel Cage



Customer :

Product line : NEMA Premium Efficiency Three-Phase

Product code : 12385116

Catalog # : 01536ST3HIE254T-W22

TORQUE AND CURRENT VS SPEED CURVE

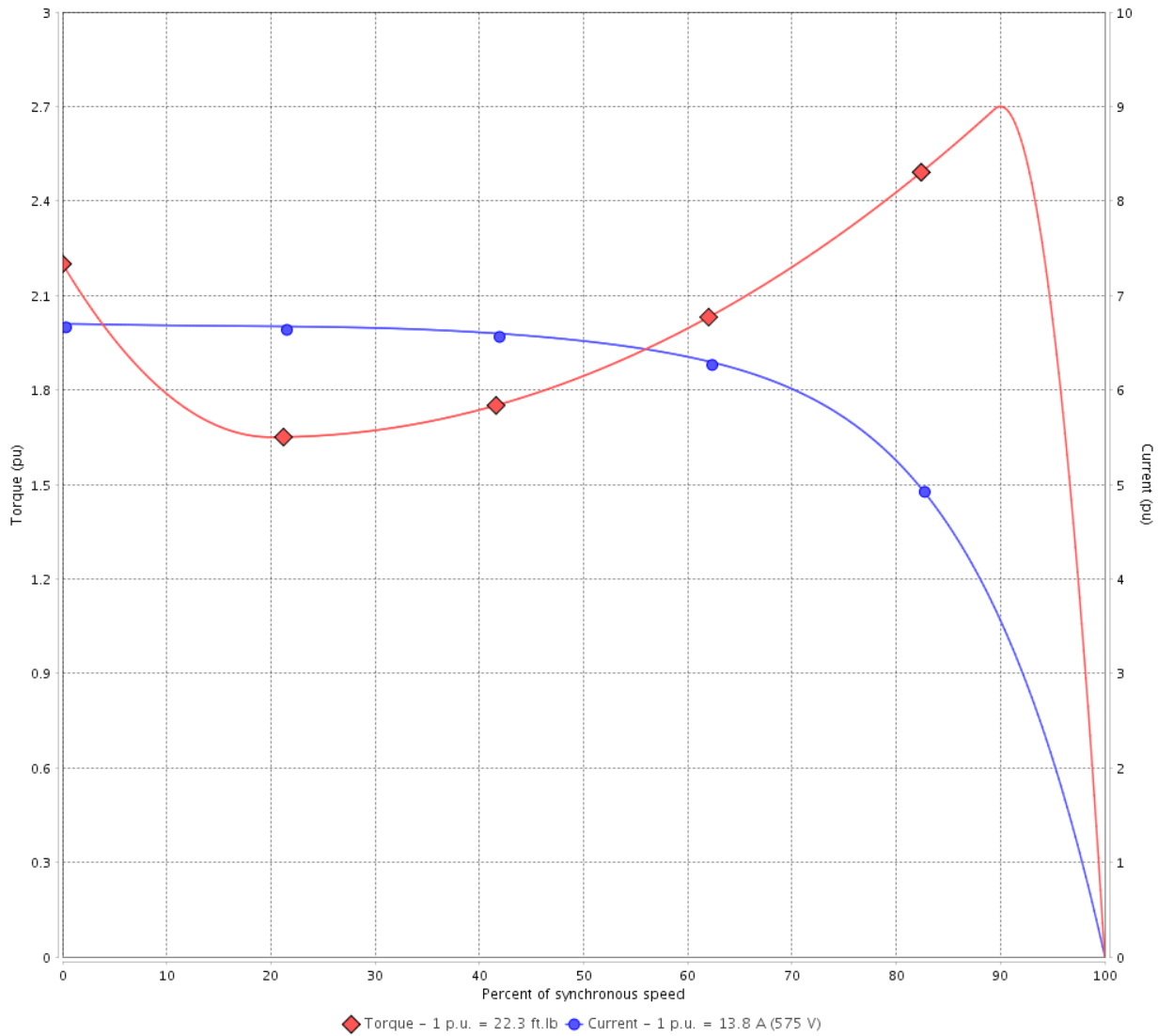

Performance : 575 V 60 Hz 2P

Rated current	: 13.8 A	Moment of inertia (J)	: 1.26 sq.ft.lb
LRC	: 6.7	Duty cycle	: Cont.(S1)
Rated torque	: 22.3 ft.lb	Insulation class	: F
Locked rotor torque	: 220 %	Service factor	: 1.25
Breakdown torque	: 270 %	Temperature rise	: 80 K
Rated speed	: 3530 rpm	Design	: B

Locked rotor time : 45s (cold) 25s (hot)

Rev.	Changes Summary	Performed	Checked	Date
Performed by			Page 2 / 6	Revision
Checked by				
Date	13/04/2022			

LOAD PERFORMANCE CURVE

Three Phase Induction Motor - Squirrel Cage



Customer : _____

Product line : NEMA Premium Efficiency Three-Phase

Product code : 12385116

Catalog # : 01536ST3HIE254T-W22

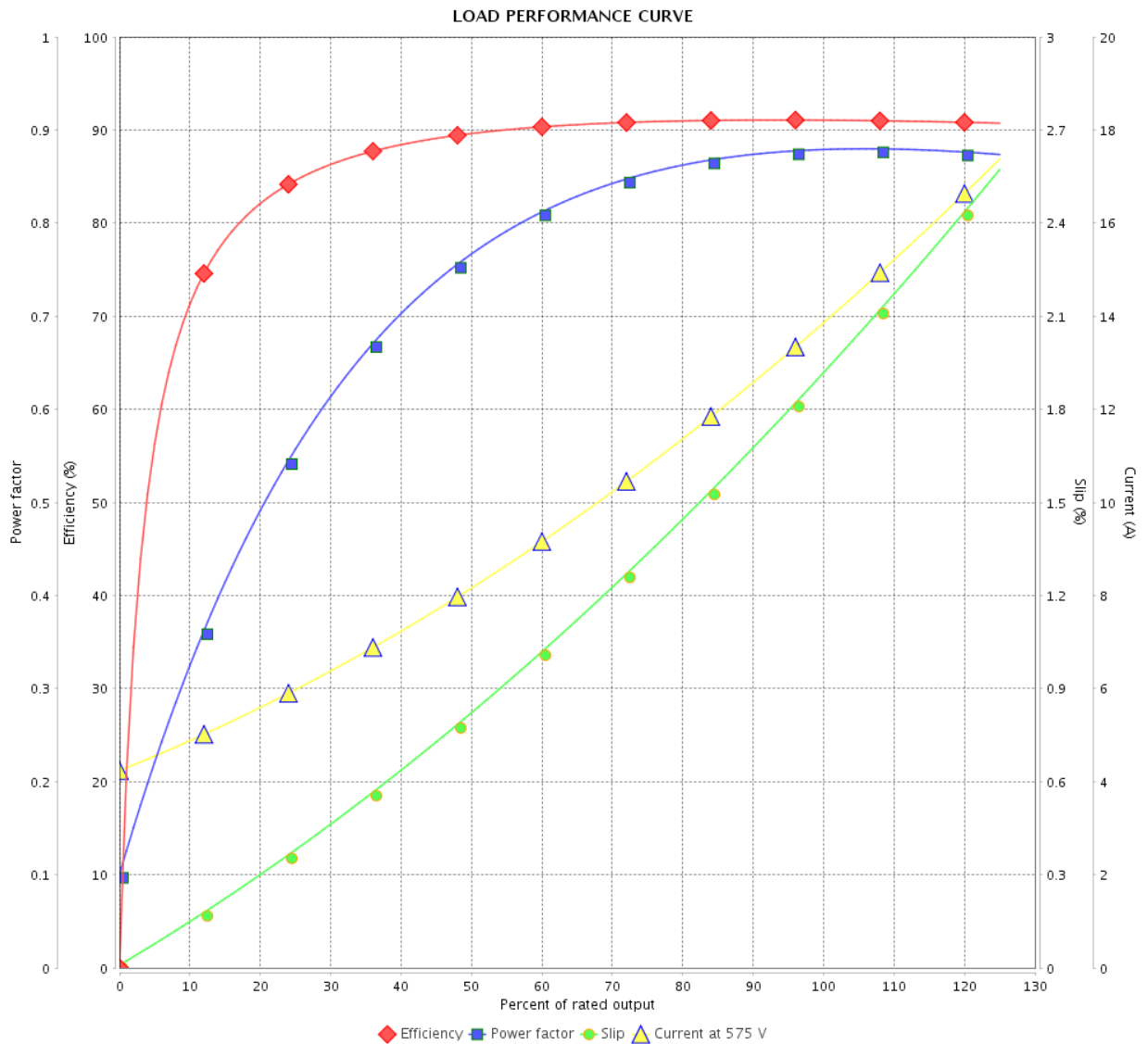

Performance : 575 V 60 Hz 2P

Rated current : 13.8 A
 LRC : 6.7
 Rated torque : 22.3 ft.lb
 Locked rotor torque : 220 %
 Breakdown torque : 270 %
 Rated speed : 3530 rpm

Moment of inertia (J) : 1.26 sq.ft.lb
 Duty cycle : Cont.(S1)
 Insulation class : F
 Service factor : 1.25
 Temperature rise : 80 K
 Design : B

Rev.	Changes Summary	Performed	Checked	Date	
Performed by					
Checked by					
Date					13/04/2022
		Page	Revision		
		3 / 6			

THERMAL LIMIT CURVE



Three Phase Induction Motor - Squirrel Cage

Customer :

Product line : NEMA Premium Efficiency Three-Phase
Product code : 12385116
Catalog # : 01536ST3HIE254T-W22

Performance : 575 V 60 Hz 2P

Rated current	: 13.8 A	Moment of inertia (J)	: 1.26 sq.ft.lb
LRC	: 6.7	Duty cycle	: Cont.(S1)
Rated torque	: 22.3 ft.lb	Insulation class	: F
Locked rotor torque	: 220 %	Service factor	: 1.25
Breakdown torque	: 270 %	Temperature rise	: 80 K
Rated speed	: 3530 rpm	Design	: B

Heating constant

Cooling constant

Rev.	Changes Summary	Performed	Checked	Date
Performed by				
Checked by			Page	Revision
Date	13/04/2022		4 / 6	

THERMAL LIMIT CURVE

Three Phase Induction Motor - Squirrel Cage



Customer : _____

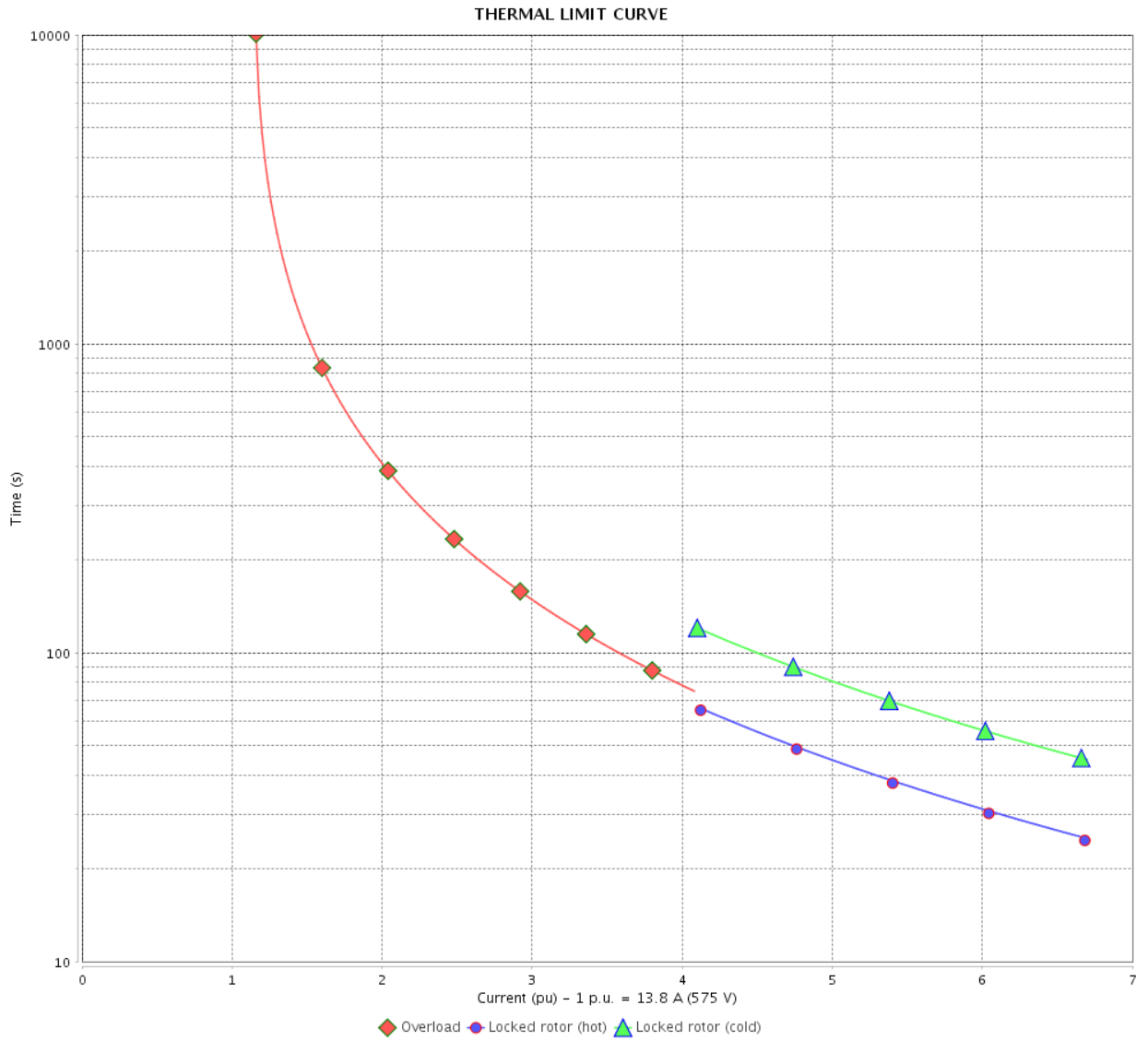

Rev.	Changes Summary	Performed	Checked	Date
Performed by		Page 5 / 6		Revision
Checked by				
Date				

VFD OPERATION CURVE

Three Phase Induction Motor - Squirrel Cage



Customer :

Product line : NEMA Premium Efficiency Three-Phase

Product code : 12385116

Catalog # : 01536ST3HIE254T-W22

VFD OPERATION CURVE

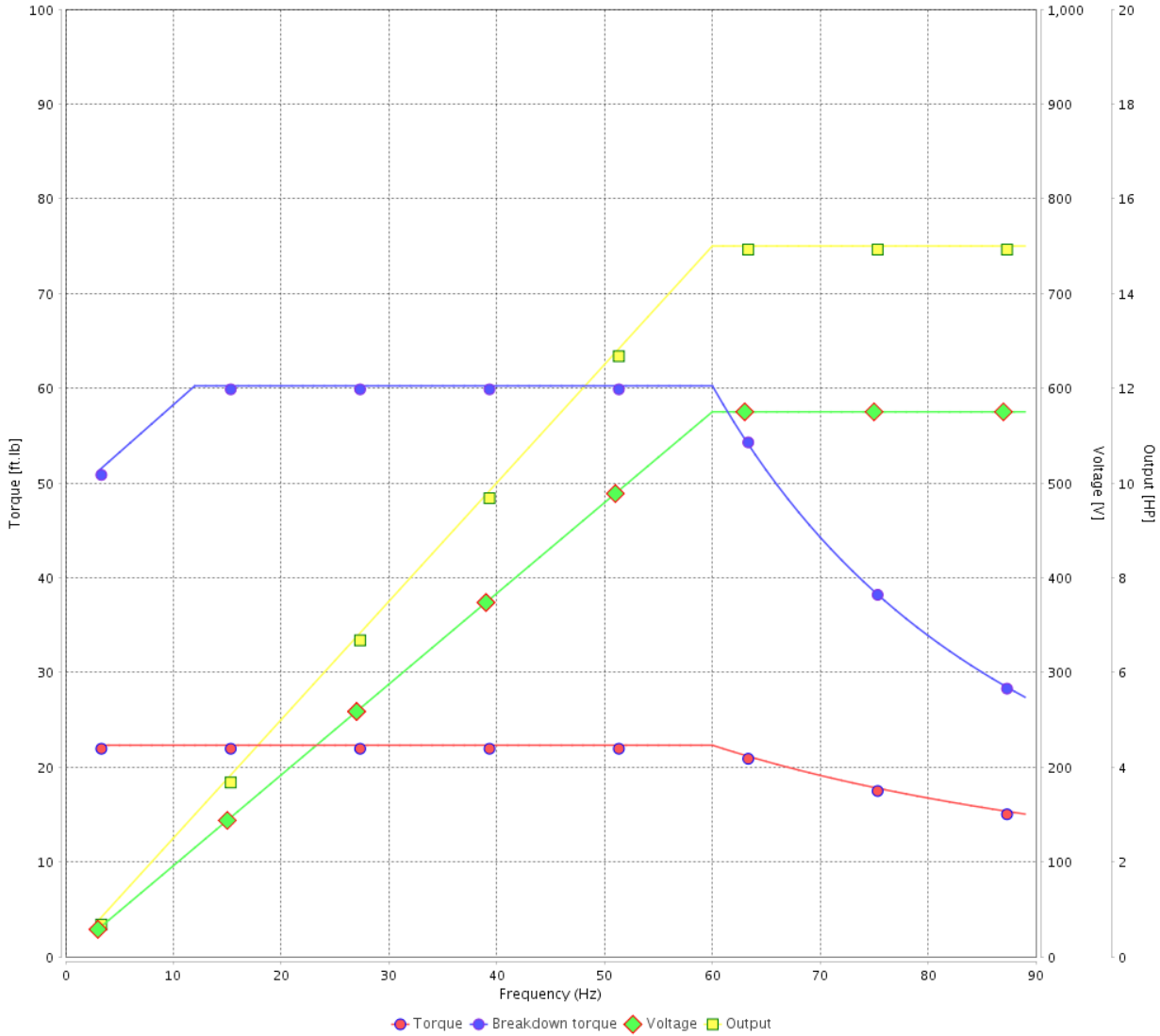

Performance : 575 V 60 Hz 2P

Rated current : 13.8 A
 LRC : 6.7
 Rated torque : 22.3 ft.lb
 Locked rotor torque : 220 %
 Breakdown torque : 270 %
 Rated speed : 3530 rpm

Moment of inertia (J) : 1.26 sq.ft.lb
 Duty cycle : Cont.(S1)
 Insulation class : F
 Service factor : 1.25
 Temperature rise : 80 K
 Design : B

Rev.	Changes Summary	Performed	Checked	Date
Performed by			Page 6 / 6	Revision
Checked by				
Date	13/04/2022			

1 2 3 4 5 6

A

B

C

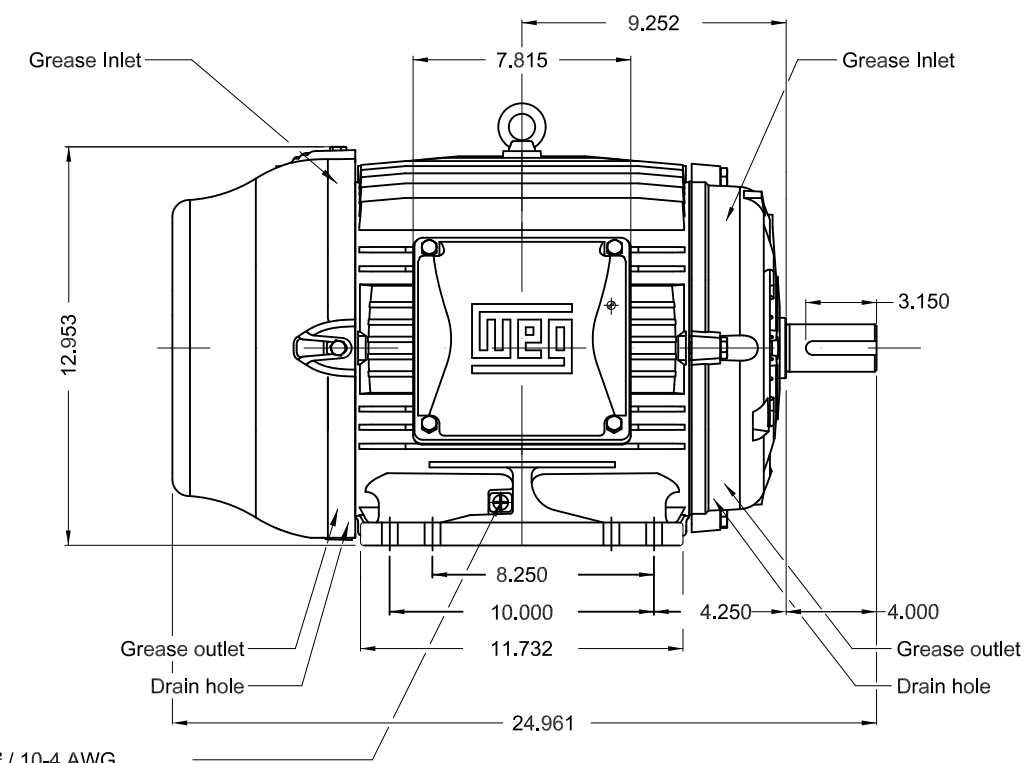
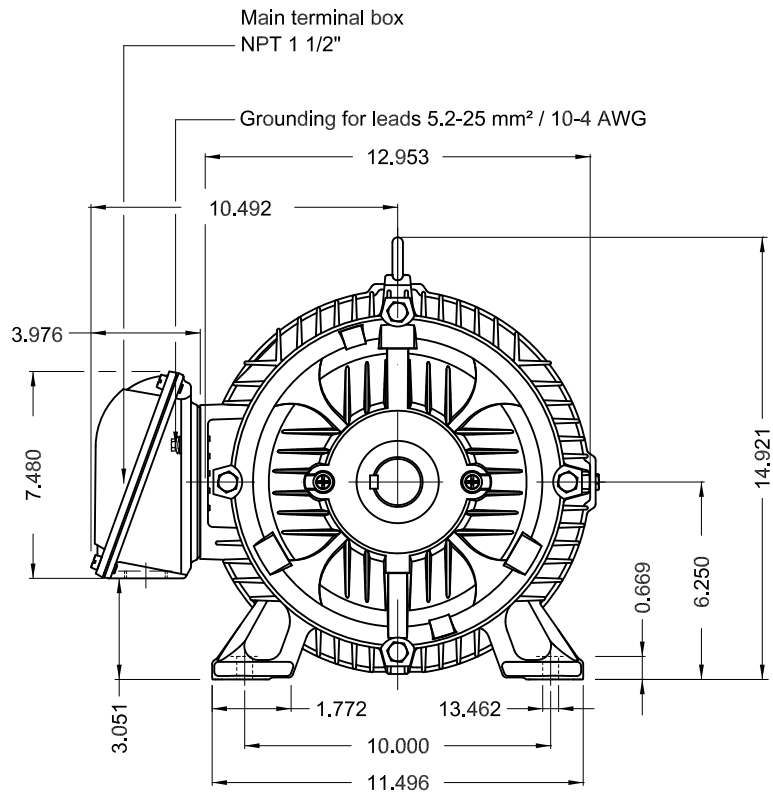

Grounding for leads 5.2-25 mm² / 10-4 AWG

D

E

Without vertical jackscrews
 Color RAL 5009
 Painting plan 202E
 Mounting B3R(D)

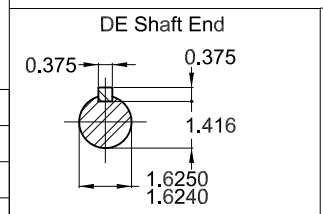

15 HP 02 Poles 60 Hz A

ECM	LOC	SUMMARY OF MODIFICATIONS	EXECUTED	CHECKED	RELEASED	DATE	VER
EXECUTED	PIRWBUSER	THREE PH. MOTOR IEEE 841 W22 PREM. EFF.					
CHECKED		FRAME 254/6T IP55 TEFC					
RELEASED							
REL DT.	WMO	Jaragua do Sul	Product Engineering	SHEET	1 / 1		

PREVIEW
WDD





NEMA
Premium
W22



FOR SAFE AREA
Mod.TE1BFOXON
CC029A



Class I, Div 2, Gr A, B, C and D - T3
Class I, Zone 2, IIC - T3
Class II, Div 2, Gr F and G - T4
For use on PWM: Gr. A, B, C, D and F,
VT 1000:1, CT 20:1, 1.00SF - T3A

IE015502W22IS



Inverter Duty Motor
Severe Duty

MADE IN BRAZIL
12385116

PH3 60Hz Fr. 254/6T 1000m.a.s.l. IP55 TEFC 284lb

V 575

A 13.8

HP 15

kW 11

SF 1.25

SFA 17.3

RPM 3530

PF 0.88

AMB 40°C

INS cl. F DT80K

NEMA NOM EFF 91.0%

DUTY CONT.

DES B Code G

GUARANT. EFF 89.5%

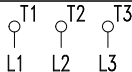

575V



→ 6309-C3 (13g) 45BC03X30

→ 6209-C3 (9g) 45BC02X30



MOBIL POLYREX EM (19000h)

