

DATA SHEET



Three Phase Induction Motor - Squirrel Cage

Customer :				
Product line	: W40 NEMA Premium Efficiency Three-Phase	Product code :	14495152	
		Catalog # :	02518OT3H284TS-W40	
Frame	: 284TS	Locked rotor time	: 64s (cold) 36s (hot)	
Output	: 25 HP (18.5 kW)	Temperature rise	: 80 K	
Poles	: 4	Duty cycle	: Cont.(S1)	
Frequency	: 60 Hz	Ambient temperature	: -20°C to +40°C	
Rated voltage	: 575 V	Altitude	: 1000 m.a.s.l.	
Rated current	: 23.6 A	Protection degree	: IP23	
L. R. Amperes	: 149 A	Cooling method	: IC01 - ODP	
LRC	: 6.3x(Code G)	Mounting	: F-1	
No load current	: 8.80 A	Rotation ¹	: Both (CW and CCW)	
Rated speed	: 1765 rpm	Noise level ²	: 64.0 dB(A)	
Slip	: 1.94 %	Starting method	: Direct On Line	
Rated torque	: 74.2 ft.lb	Approx. weight ³	: 347 lb	
Locked rotor torque	: 250 %			
Breakdown torque	: 270 %			
Insulation class	: F			
Service factor	: 1.25			
Moment of inertia (J)	: 3.71 sq.ft.lb			
Design	: B			
Output	25% 50% 75% 100%	Foundation loads		
Efficiency (%)	92.8 93.0 93.6 93.6	Max. traction		
Power Factor	0.45 0.69 0.80 0.84	Max. compression		
		<u>Drive end</u>	<u>Non drive end</u>	
Bearing type	:	6311 Z C3	6211 Z C3	
Sealing	:	Without Bearing Seal	Without Bearing Seal	
Lubrication interval	:	20000 h	20000 h	
Lubricant amount	:	18 g	11 g	
Lubricant type	:	Mobil Polyrex EM		
Notes				
This revision replaces and cancel the previous one, which must be eliminated. (1) Looking the motor from the shaft end. (2) Measured at 1m and with tolerance of +3dB(A). (3) Approximate weight subject to changes after manufacturing process. (4) At 100% of full load.		These are average values based on tests with sinusoidal power supply, subject to the tolerances stipulated in NEMA MG-1.		
Rev.	Changes Summary	Performed	Checked	Date
Performed by				
Checked by			Page	Revision
Date	13/04/2022		1 / 6	

TORQUE AND CURRENT VS SPEED CURVE

Three Phase Induction Motor - Squirrel Cage



Customer :

Product line : W40 NEMA Premium Efficiency
Three-Phase

Product code : 14495152

Catalog # : 02518OT3H284TS-W40

TORQUE AND CURRENT VS SPEED CURVE

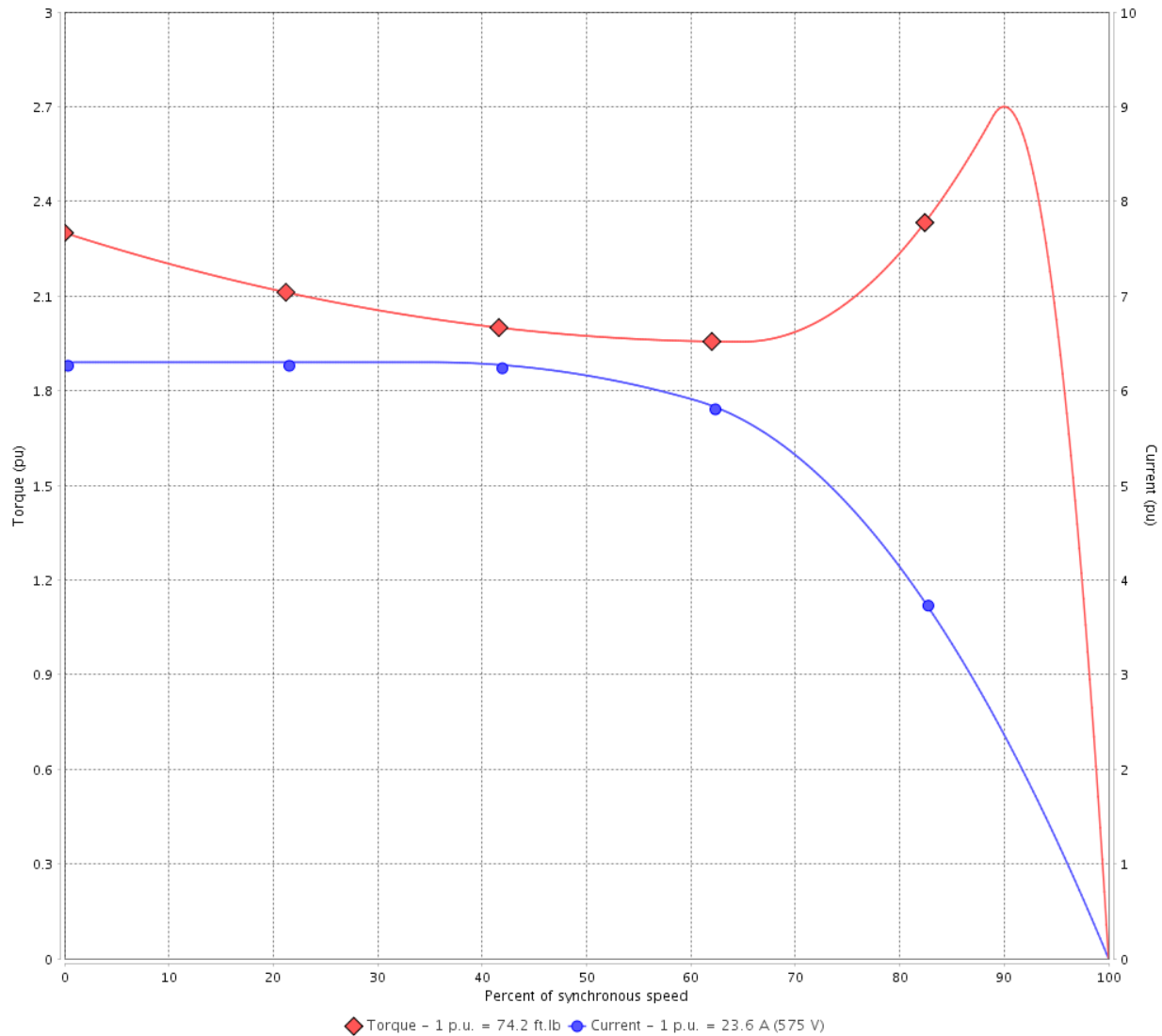

Performance : 575 V 60 Hz 4P

Rated current	: 23.6 A	Moment of inertia (J)	: 3.71 sq.ft.lb
LRC	: 6.3	Duty cycle	: Cont.(S1)
Rated torque	: 74.2 ft.lb	Insulation class	: F
Locked rotor torque	: 250 %	Service factor	: 1.25
Breakdown torque	: 270 %	Temperature rise	: 80 K
Rated speed	: 1765 rpm	Design	: B

Locked rotor time : 64s (cold) 36s (hot)

Rev.	Changes Summary	Performed	Checked	Date
Performed by			Page 2 / 6	Revision
Checked by				
Date	13/04/2022			

LOAD PERFORMANCE CURVE

Three Phase Induction Motor - Squirrel Cage



Customer :

Product line : W40 NEMA Premium Efficiency
Three-Phase

Product code : 14495152

Catalog # : 02518OT3H284TS-W40

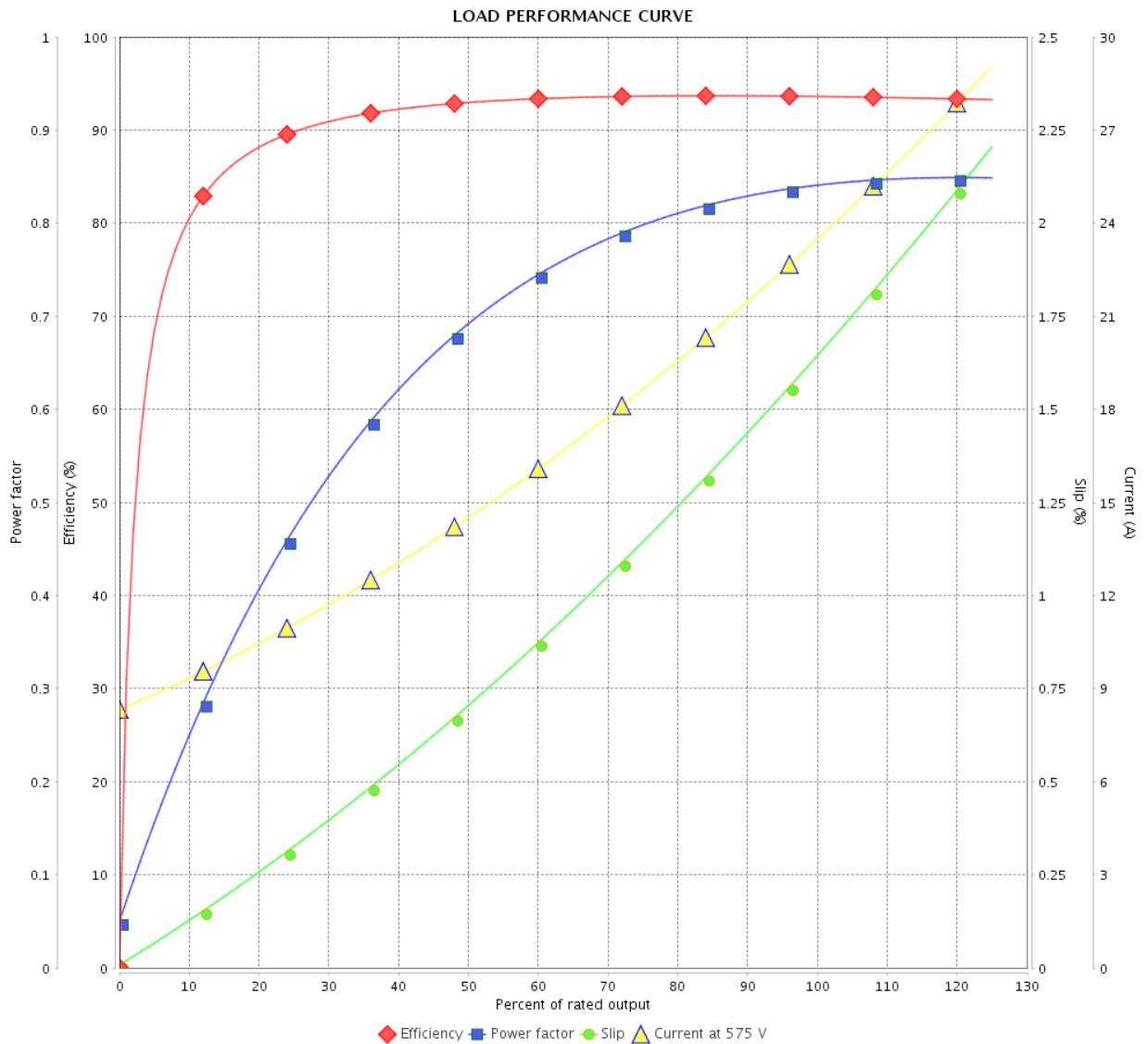

Performance : 575 V 60 Hz 4P

Rated current : 23.6 A
 LRC : 6.3
 Rated torque : 74.2 ft.lb
 Locked rotor torque : 250 %
 Breakdown torque : 270 %
 Rated speed : 1765 rpm

Moment of inertia (J) : 3.71 sq.ft.lb
 Duty cycle : Cont.(S1)
 Insulation class : F
 Service factor : 1.25
 Temperature rise : 80 K
 Design : B

Rev.	Changes Summary	Performed	Checked	Date
Performed by				
Checked by				
Date				
		Page	Revision	
		3 / 6		

THERMAL LIMIT CURVE

Three Phase Induction Motor - Squirrel Cage



Customer :

Product line : W40 NEMA Premium Efficiency
Three-Phase

Product code : 14495152

Catalog # : 02518OT3H284TS-W40

Performance : 575 V 60 Hz 4P

Rated current : 23.6 A
LRC : 6.3
Rated torque : 74.2 ft.lb
Locked rotor torque : 250 %
Breakdown torque : 270 %
Rated speed : 1765 rpm

Moment of inertia (J) : 3.71 sq.ft.lb
Duty cycle : Cont.(S1)
Insulation class : F
Service factor : 1.25
Temperature rise : 80 K
Design : B

Heating constant

Cooling constant

Rev.	Changes Summary	Performed	Checked	Date
Performed by				
Checked by			Page	Revision
Date	13/04/2022		4 / 6	

THERMAL LIMIT CURVE

Three Phase Induction Motor - Squirrel Cage



Customer : _____

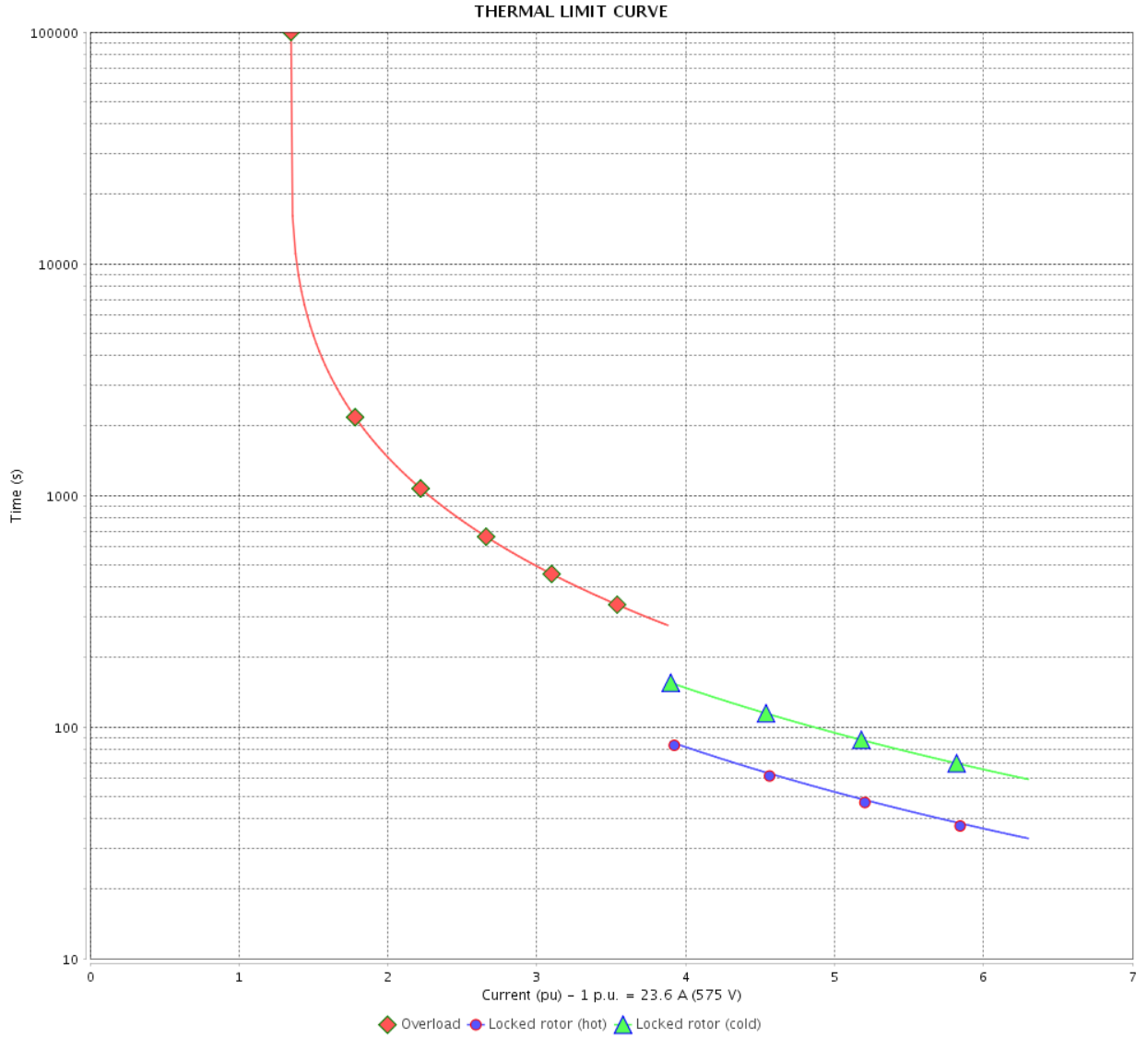

Rev.	Changes Summary	Performed	Checked	Date
Performed by		Page 5 / 6		Revision
Checked by				
Date				

VFD OPERATION CURVE

Three Phase Induction Motor - Squirrel Cage



Customer :

Product line : W40 NEMA Premium Efficiency Three-Phase

Product code : 14495152

Catalog # : 02518OT3H284TS-W40

VFD OPERATION CURVE

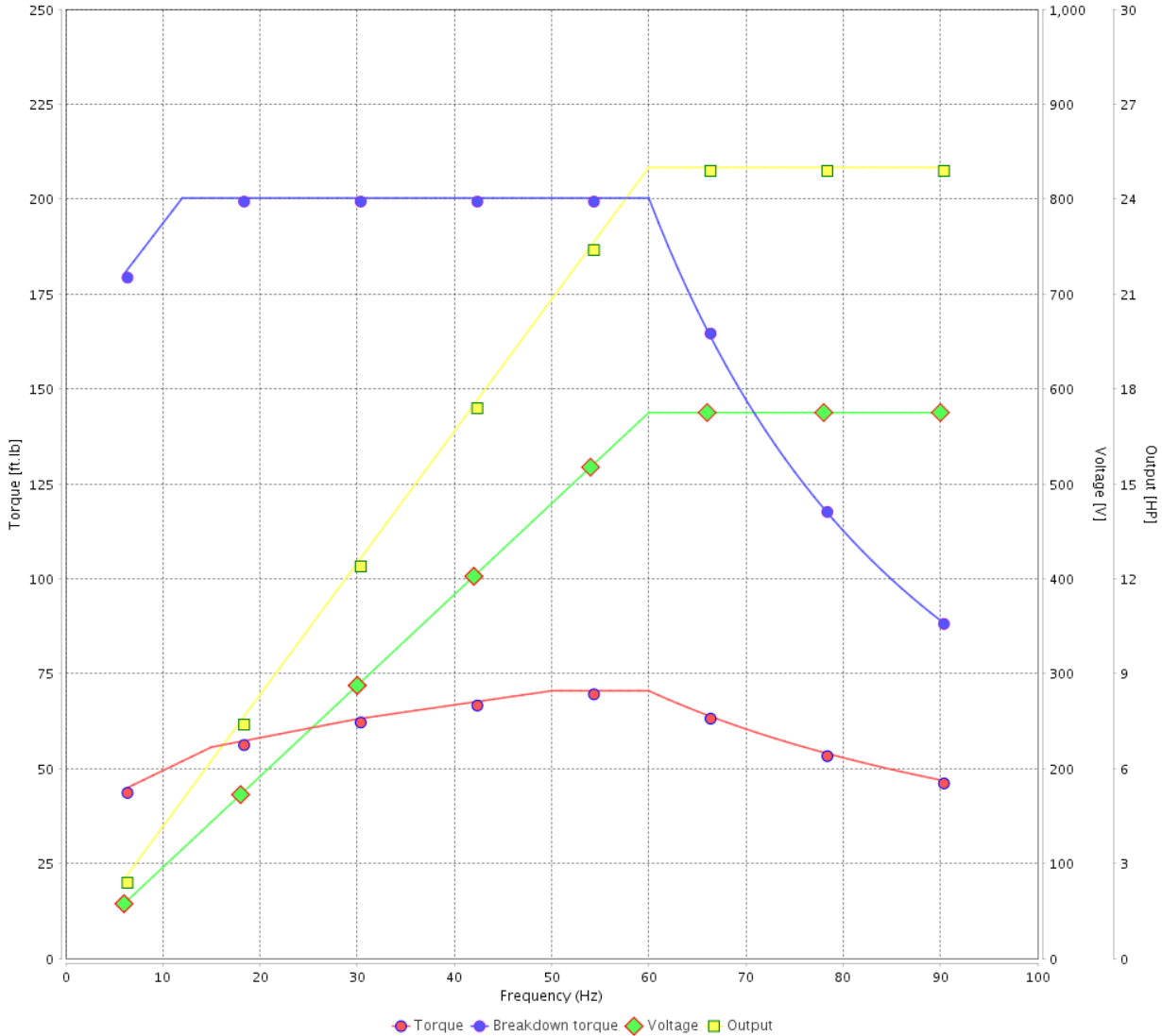

Performance : 575 V 60 Hz 4P

Rated current : 23.6 A
 LRC : 6.3
 Rated torque : 74.2 ft.lb
 Locked rotor torque : 250 %
 Breakdown torque : 270 %
 Rated speed : 1765 rpm

Moment of inertia (J) : 3.71 sq.ft.lb
 Duty cycle : Cont.(S1)
 Insulation class : F
 Service factor : 1.25
 Temperature rise : 80 K
 Design : B

Rev.	Changes Summary	Performed	Checked	Date
Performed by			Page 6 / 6	Revision
Checked by				
Date	13/04/2022			

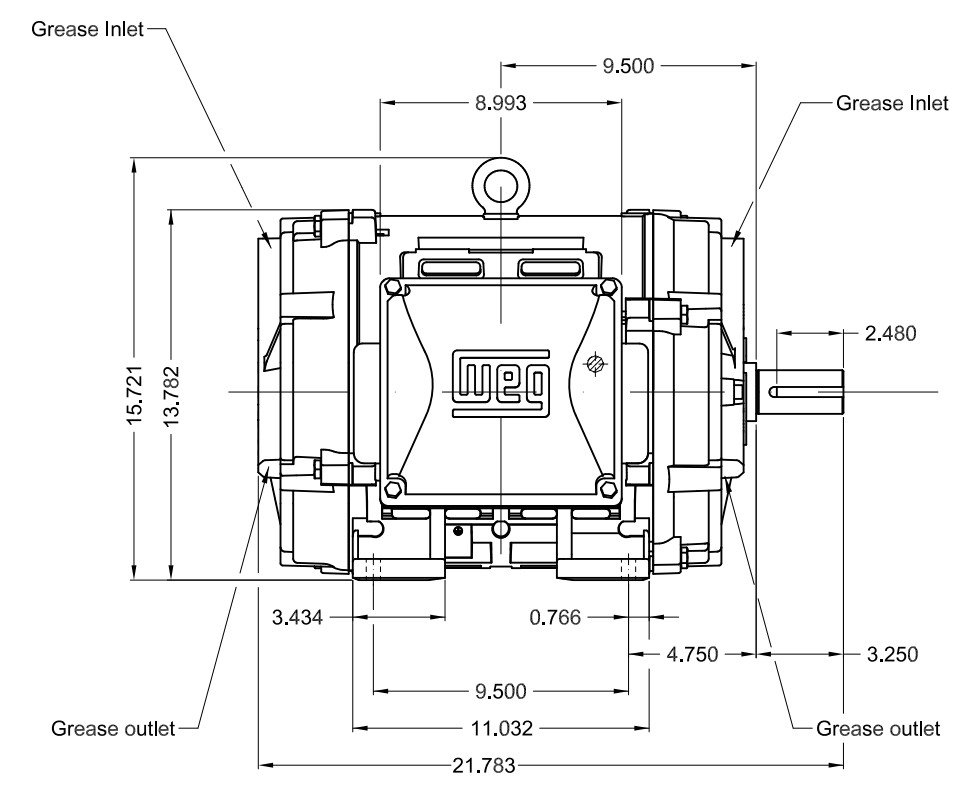
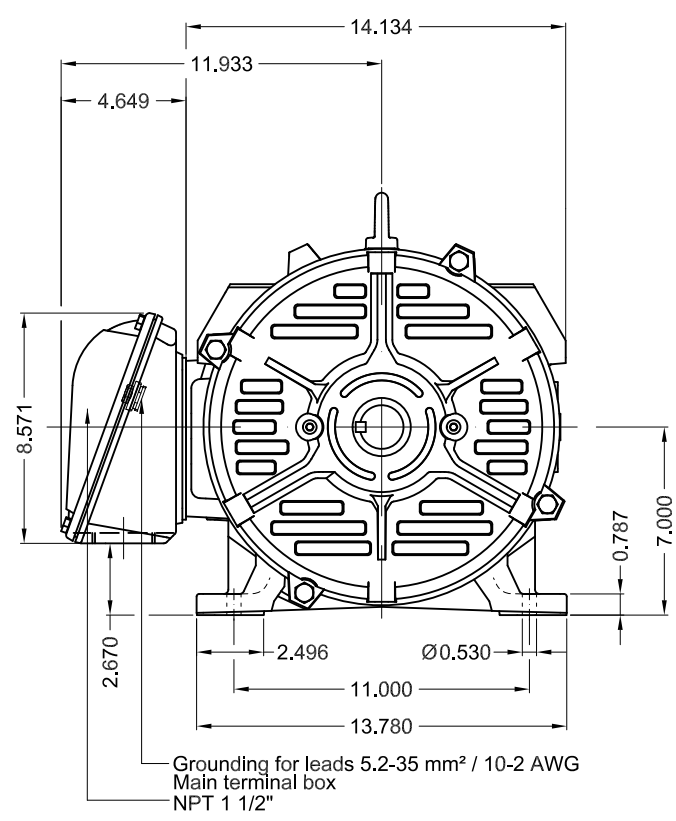

TS shaft end
Color RAL 5009
Painting plan 203A
Mounting NEMA F-1
Mounting B3R(D)

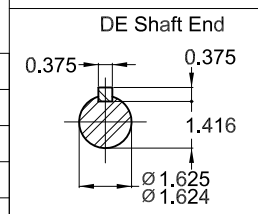

25 HP 04 Poles 60 Hz A

1:7

ECM	LOC	SUMMARY OF MODIFICATIONS	EXECUTED	CHECKED	RELEASED	DATE	VER
EXECUTED	PIRWBUSER	THREE PH. MOTOR W40 PREM. EFF.					
CHECKED		FRAME 284TS IP23 ODP					
RELEASED							
REL DT.		WMO Jaragua do Sul	Product Engineering	SHEET	1 / 1		

PREVIEW
WDD



MODEL 025180T3H284TS-W40
MADE IN BRAZIL
14495152

WEG **W40 NEMA**
CC029A Premium
Inverter Duty Motor



IEC 60034-1
MOD.T01#FOXON



For use on PWM, VT 1000:1, CT 3:1, 1.0SF

PH 3	FR 284TS	HP(kW) 25(18.5)		Hz 60
V 575		A 23.6		IP23
NEMA NOM EFF		93.6	%	RPM 1770
ENCL ODP	DUTY CONT.		INS. CL. F Δ T 80 K	
PF 0.84		DES B	CODE G	AMB. 40°C
SF 1.25		SFA 29.5		ALT 1000 m.a.s.l.

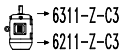
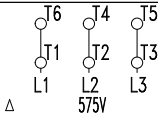

MOBIL POLYREX EM
18 g 20000 h

344 Lbs