

DATA SHEET



Three Phase Induction Motor - Squirrel Cage

Customer :					
Product line	: NEMA Premium Efficiency Three-Phase	Product code :	14407648		
		Catalog # :	02518XT3ER284TC		
Frame	: 284TC	Cooling method	: IC411 - TEFC		
Insulation class	: F	Mounting	: W-6		
Duty cycle	: Cont.(S1)	Rotation ¹	: Both (CW and CCW)		
Ambient temperature	: -20°C to +40°C	Starting method	: Direct On Line		
Altitude	: 1000 m.a.s.l.	Approx. weight ²	: 485 lb		
Protection degree	: IP55	Moment of inertia (J)	: 4.54 sq.ft.lb		
Design	: B				
Output [HP]	25	25	25	25	
Poles	4	4	4	4	
Frequency [Hz]	60	50	50	50	
Rated voltage [V]	230/460	380	400	415	
Rated current [A]	59.8/29.9	36.5	34.8	34.0	
L. R. Amperes [A]	490/245	234	247	258	
LRC [A]	8.2x(Code G)	6.4x(Code F)	7.1x(Code F)	7.6x(Code G)	
No load current [A]	25.0/12.5	12.5	13.4	14.5	
Rated speed [RPM]	1770	1460	1465	1470	
Slip [%]	1.67	2.67	2.33	2.00	
Rated torque [ft.lb]	74.2	90.2	89.9	89.6	
Locked rotor torque [%]	320	229	240	260	
Breakdown torque [%]	320	240	250	270	
Service factor	1.15	1.00	1.00	1.00	
Temperature rise	80 K	80 K	80 K	80 K	
Locked rotor time	36s (cold) 20s (hot)	36s (cold) 20s (hot)	36s (cold) 20s (hot)	36s (cold) 20s (hot)	
Noise level ²	68.0 dB(A)	64.0 dB(A)	64.0 dB(A)	64.0 dB(A)	
Efficiency (%)	25%	92.2	92.8	92.2	92.2
	50%	92.4	92.4	92.4	92.4
	75%	93.6	92.4	92.4	92.4
	100%	93.6	91.7	92.4	92.4
Power Factor	25%	0.42	0.47	0.45	0.42
	50%	0.67	0.72	0.70	0.68
	75%	0.78	0.81	0.79	0.78
	100%	0.83	0.84	0.83	0.82
Bearing type	: <u>Drive end</u> 6311 C3 <u>Non drive end</u> 6211 C3	Foundation loads			
Sealing	: Oil Seal Lip Seal	Max. traction	: 809 lb		
Lubrication interval	: 12213 h 13608 h	Max. compression	: 1294 lb		
Lubricant amount	: 18 g 11 g				
Lubricant type	: Mobil Polyrex EM				
Notes USABLE @208V 64.5A SF 1.15 SFA 74.2A					
This revision replaces and cancel the previous one, which must be eliminated. (1) Looking the motor from the shaft end. (2) Measured at 1m and with tolerance of +3dB(A). (3) Approximate weight subject to changes after manufacturing process. (4) At 100% of full load.			These are average values based on tests with sinusoidal power supply, subject to the tolerances stipulated in NEMA MG-1.		
Rev.	Changes Summary		Performed	Checked	Date
Performed by					
Checked by				Page	Revision
Date	13/04/2022			1 / 22	

DATA SHEET

Three Phase Induction Motor - Squirrel Cage



Customer : _____

Thermal protection

ID	Application	Type	Quantity	Sensing Temperature
1	Winding	Thermostat - 2 wires	1 x Phase	155 °C

Rev.	Changes Summary	Performed	Checked	Date
Performed by				
Checked by			Page	Revision
Date	13/04/2022		2 / 22	

TORQUE AND CURRENT VS SPEED CURVE



Three Phase Induction Motor - Squirrel Cage

Customer :

Product line : NEMA Premium Efficiency Three-Phase

Product code : 14407648

Catalog # : 02518XT3ER284TC

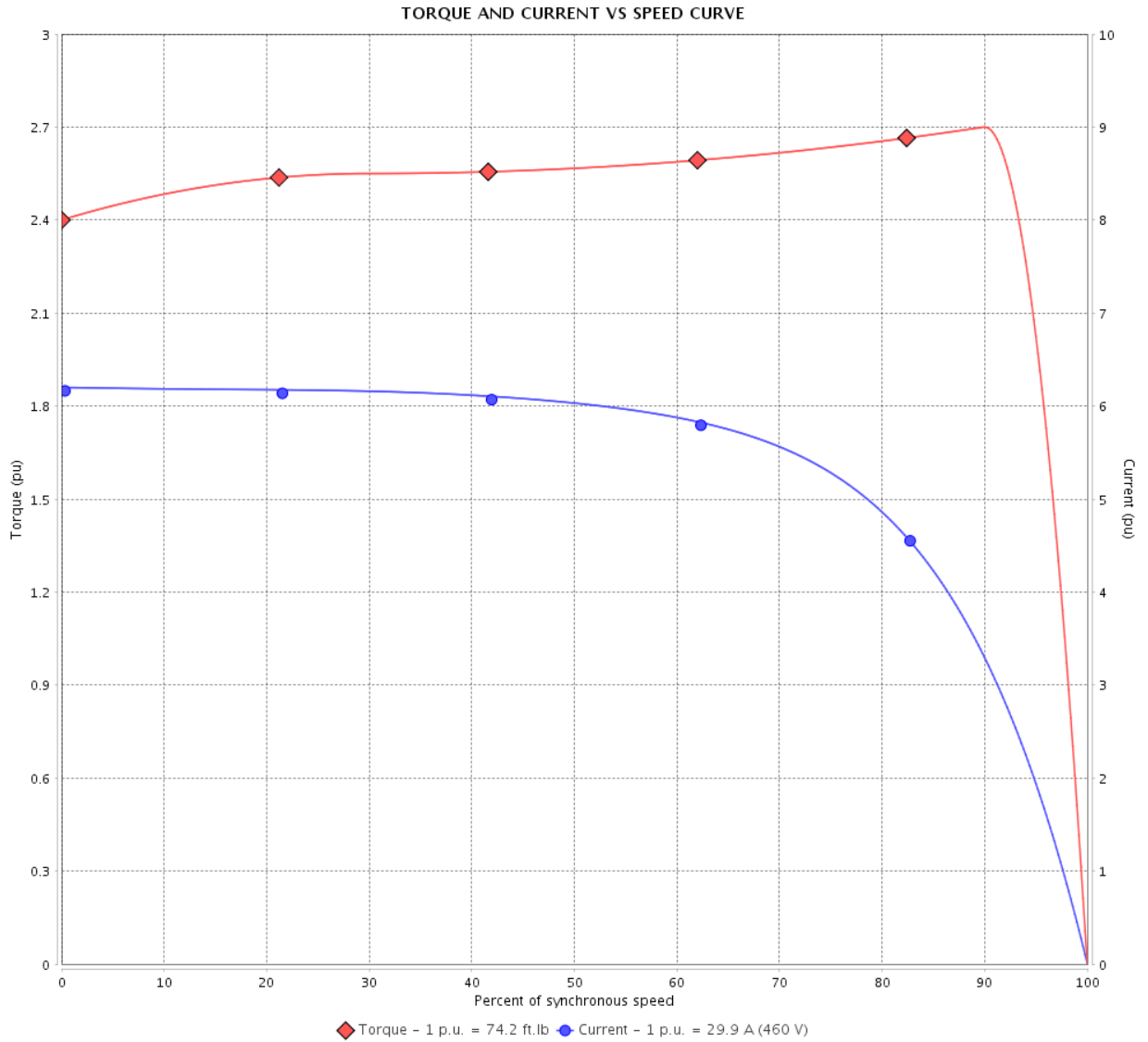

Performance : 230/460 V 60 Hz 4P

Rated current : 59.8/29.9 A
 LRC : 8.2
 Rated torque : 74.2 ft.lb
 Locked rotor torque : 320 %
 Breakdown torque : 320 %
 Rated speed : 1770 rpm

Moment of inertia (J) : 4.54 sq.ft.lb
 Duty cycle : Cont.(S1)
 Insulation class : F
 Service factor : 1.15
 Temperature rise : 80 K
 Design : B

Locked rotor time : 36s (cold) 20s (hot)

Rev.	Changes Summary	Performed	Checked	Date
Performed by			Page 3 / 22	Revision
Checked by				
Date	13/04/2022			

TORQUE AND CURRENT VS SPEED CURVE

Three Phase Induction Motor - Squirrel Cage



Customer :

Product line : NEMA Premium Efficiency Three-Phase
 Product code : 14407648
 Catalog # : 02518XT3ER284TC

TORQUE AND CURRENT VS SPEED CURVE

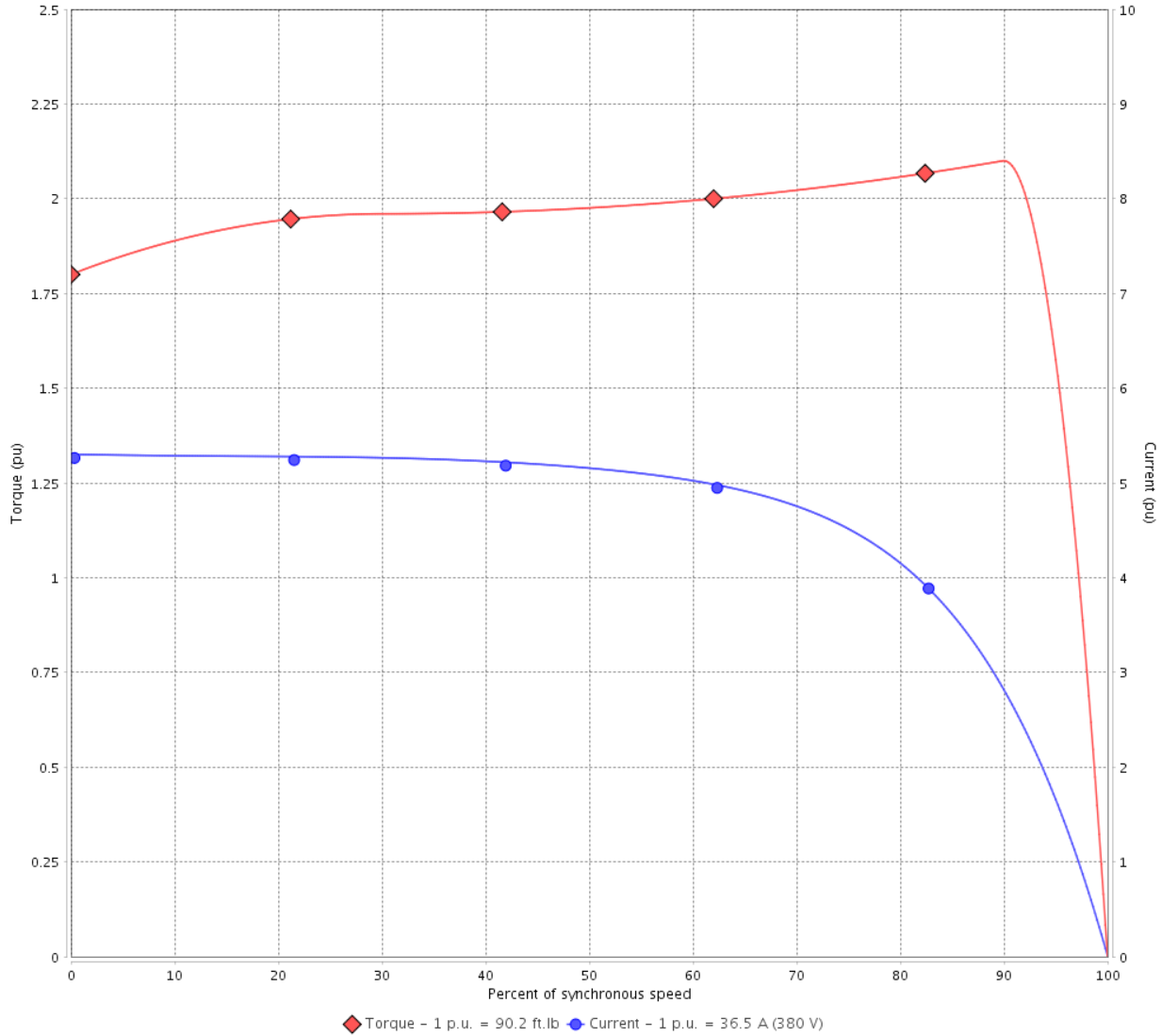

Performance : 380 V 50 Hz 4P IE2

Rated current	: 36.5 A	Moment of inertia (J)	: 4.54 sq.ft.lb
LRC	: 6.4	Duty cycle	: Cont.(S1)
Rated torque	: 90.2 ft.lb	Insulation class	: F
Locked rotor torque	: 229 %	Service factor	: 1.00
Breakdown torque	: 240 %	Temperature rise	: 80 K
Rated speed	: 1460 rpm	Design	: B

Locked rotor time : 36s (cold) 20s (hot)

Rev.	Changes Summary	Performed	Checked	Date
Performed by			Page 4 / 22	Revision
Checked by				
Date	13/04/2022			

TORQUE AND CURRENT VS SPEED CURVE



Three Phase Induction Motor - Squirrel Cage

Customer :

Product line : NEMA Premium Efficiency Three-Phase

Product code : 14407648

Catalog # : 02518XT3ER284TC

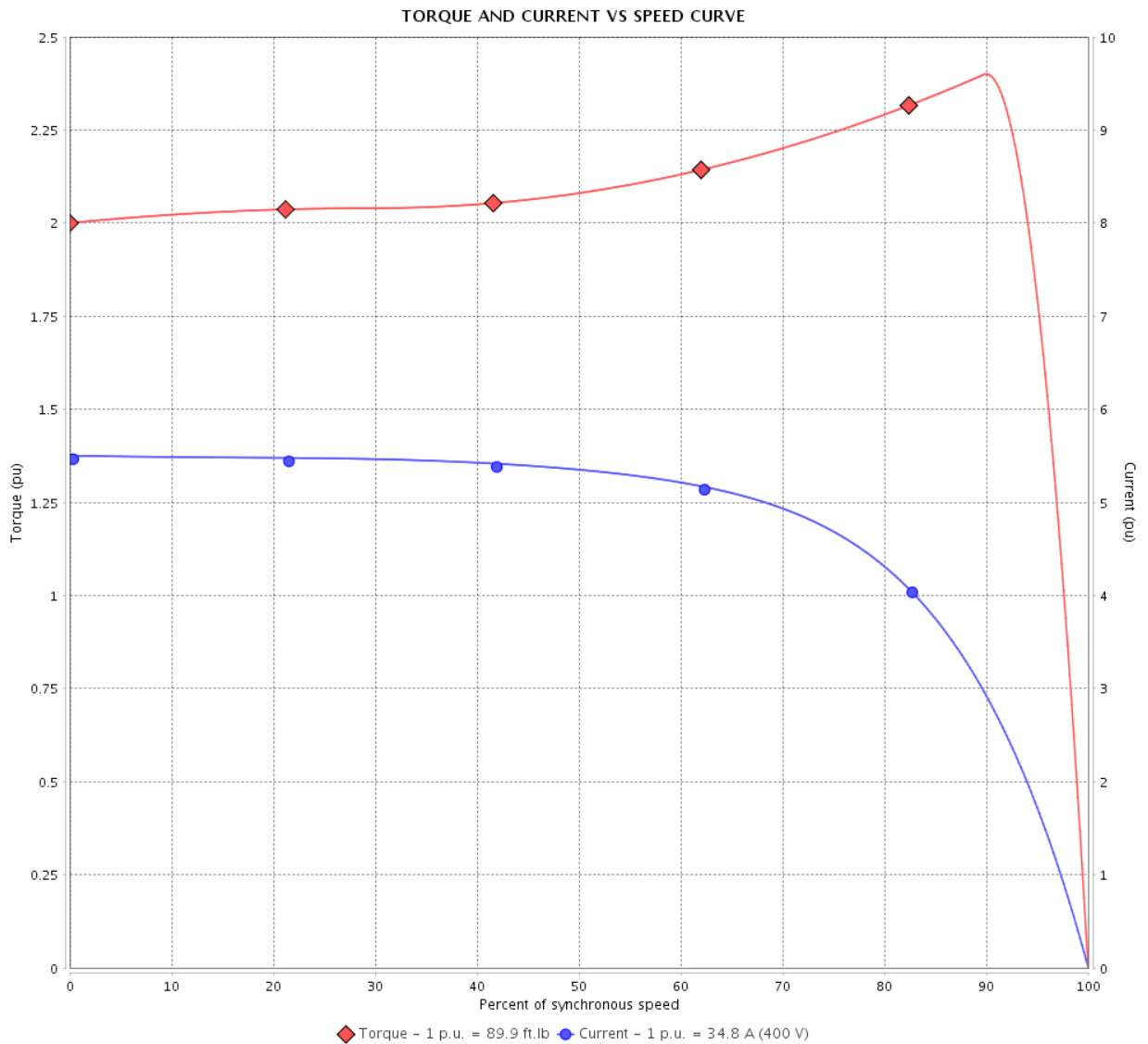

Performance : 400 V 50 Hz 4P IE2

Rated current : 34.8 A
 LRC : 7.1
 Rated torque : 89.9 ft.lb
 Locked rotor torque : 240 %
 Breakdown torque : 250 %
 Rated speed : 1465 rpm

Moment of inertia (J) : 4.54 sq.ft.lb
 Duty cycle : Cont.(S1)
 Insulation class : F
 Service factor : 1.00
 Temperature rise : 80 K
 Design : B

Locked rotor time : 36s (cold) 20s (hot)

Rev.	Changes Summary	Performed	Checked	Date
Performed by			Page 5 / 22	Revision
Checked by				
Date	13/04/2022			

TORQUE AND CURRENT VS SPEED CURVE

Three Phase Induction Motor - Squirrel Cage



Customer :

Product line : NEMA Premium Efficiency Three-Phase

Product code : 14407648

Catalog # : 02518XT3ER284TC

TORQUE AND CURRENT VS SPEED CURVE

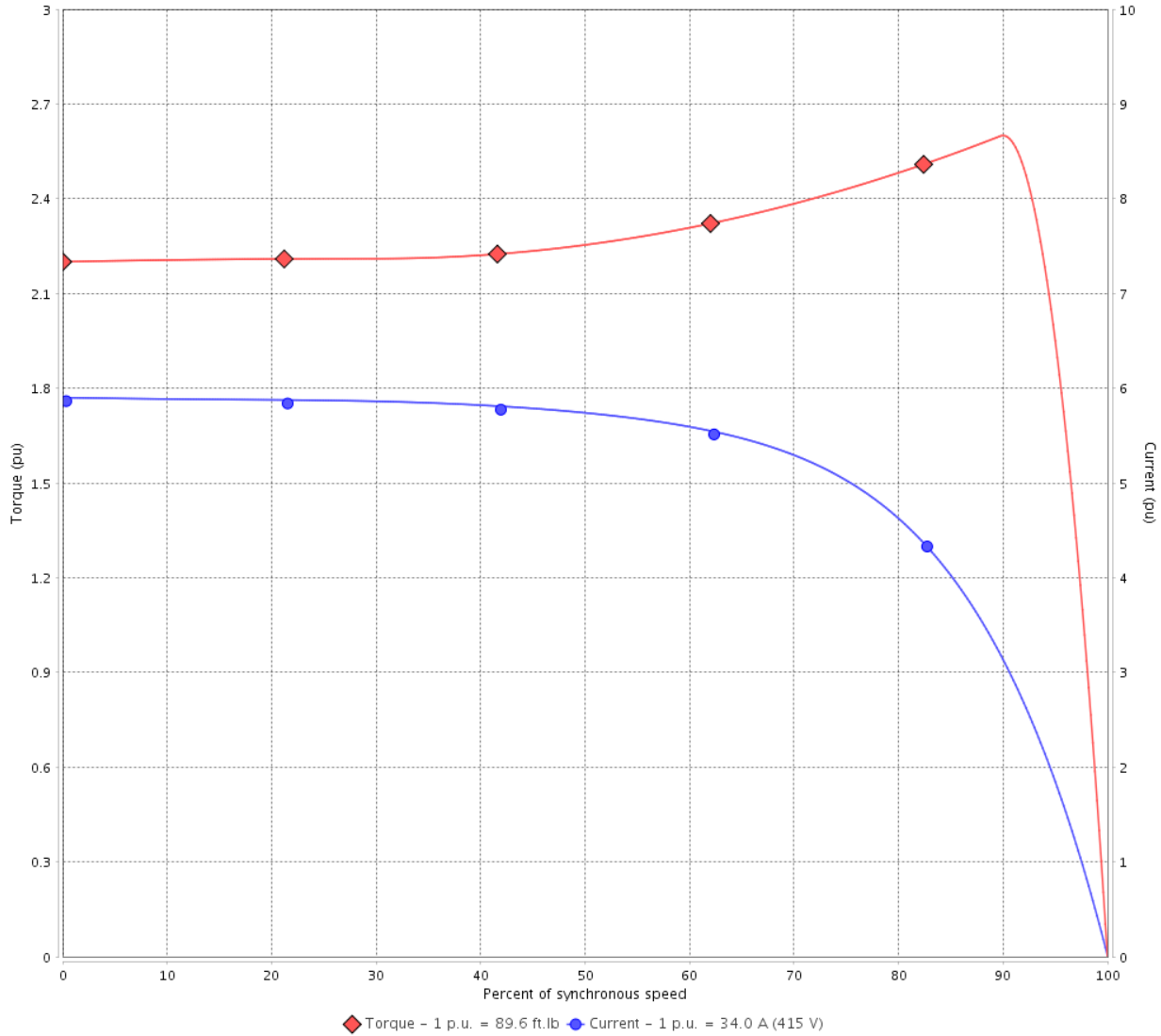

Performance : 415 V 50 Hz 4P IE2

Rated current	: 34.0 A	Moment of inertia (J)	: 4.54 sq.ft.lb
LRC	: 7.6	Duty cycle	: Cont.(S1)
Rated torque	: 89.6 ft.lb	Insulation class	: F
Locked rotor torque	: 260 %	Service factor	: 1.00
Breakdown torque	: 270 %	Temperature rise	: 80 K
Rated speed	: 1470 rpm	Design	: B

Locked rotor time : 36s (cold) 20s (hot)

Rev.	Changes Summary	Performed	Checked	Date
Performed by			Page 6 / 22	Revision
Checked by				
Date	13/04/2022			

LOAD PERFORMANCE CURVE

Three Phase Induction Motor - Squirrel Cage



Customer :

Product line : NEMA Premium Efficiency Three-Phase

Product code : 14407648

Catalog # : 02518XT3ER284TC

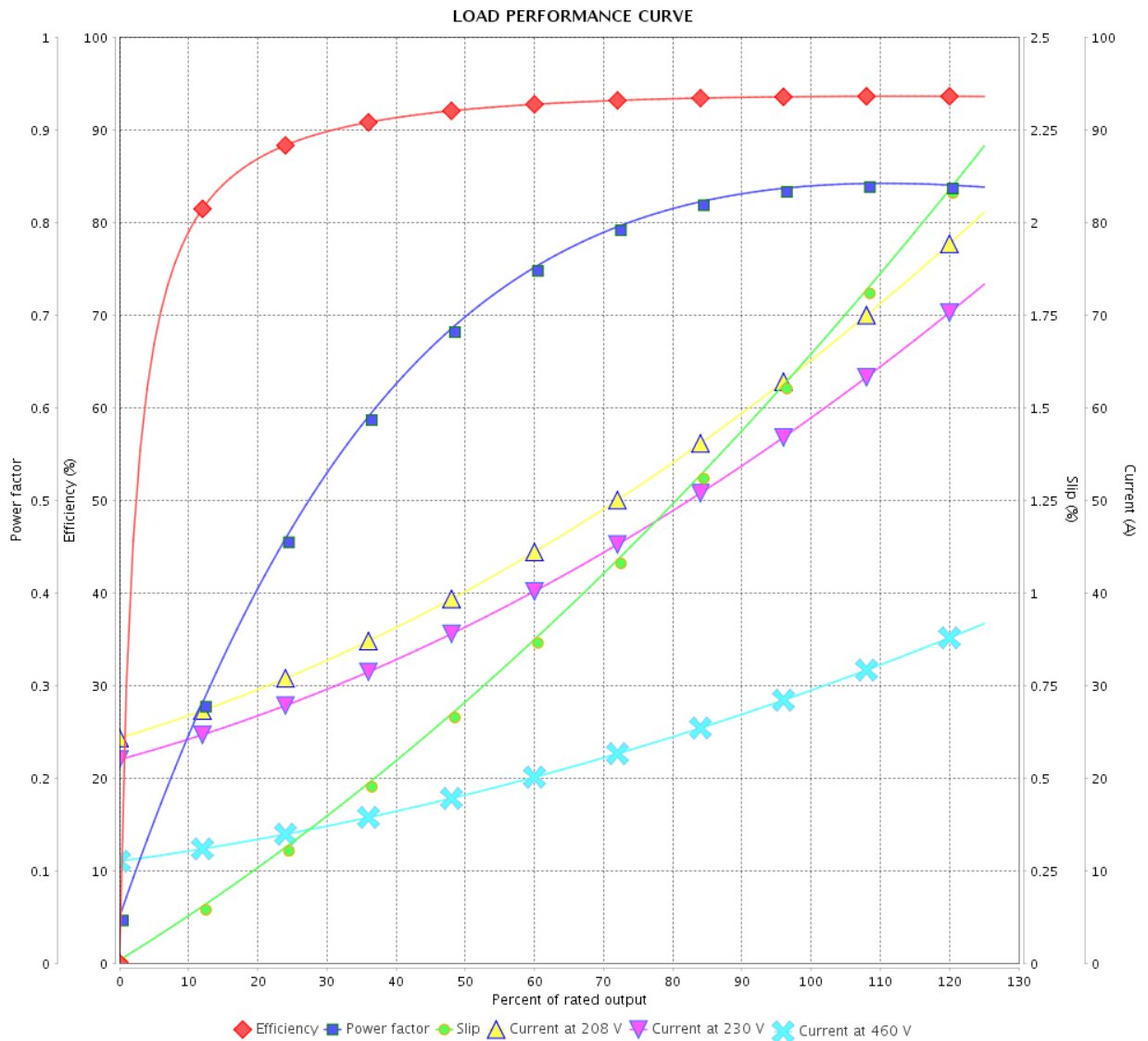

Performance : 230/460 V 60 Hz 4P

Rated current : 59.8/29.9 A
 LRC : 8.2
 Rated torque : 74.2 ft.lb
 Locked rotor torque : 320 %
 Breakdown torque : 320 %
 Rated speed : 1770 rpm

Moment of inertia (J) : 4.54 sq.ft.lb
 Duty cycle : Cont.(S1)
 Insulation class : F
 Service factor : 1.15
 Temperature rise : 80 K
 Design : B

Rev.	Changes Summary	Performed	Checked	Date
Performed by			Page 7 / 22	Revision
Checked by				
Date	13/04/2022			

LOAD PERFORMANCE CURVE

Three Phase Induction Motor - Squirrel Cage



Customer :

Product line : NEMA Premium Efficiency Three-Phase

Product code : 14407648

Catalog # : 02518XT3ER284TC

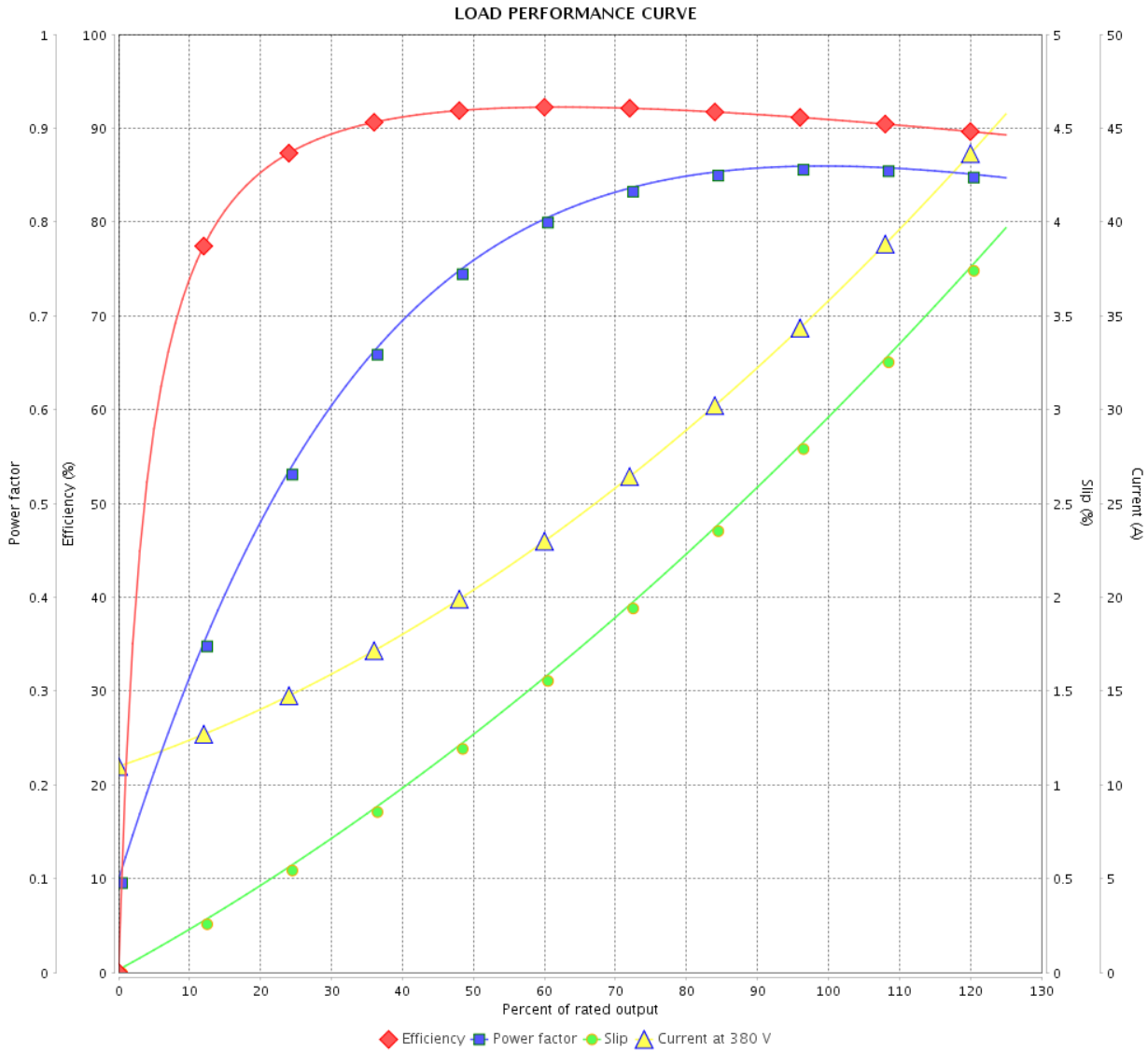

Performance : 380 V 50 Hz 4P IE2

Rated current : 36.5 A
 LRC : 6.4
 Rated torque : 90.2 ft.lb
 Locked rotor torque : 229 %
 Breakdown torque : 240 %
 Rated speed : 1460 rpm

Moment of inertia (J) : 4.54 sq.ft.lb
 Duty cycle : Cont.(S1)
 Insulation class : F
 Service factor : 1.00
 Temperature rise : 80 K
 Design : B

Rev.	Changes Summary	Performed	Checked	Date
Performed by		Page		Revision
Checked by		8 / 22		
Date	13/04/2022			

LOAD PERFORMANCE CURVE

Three Phase Induction Motor - Squirrel Cage



Customer : _____

Product line : NEMA Premium Efficiency Three-Phase

Product code : 14407648

Catalog # : 02518XT3ER284TC

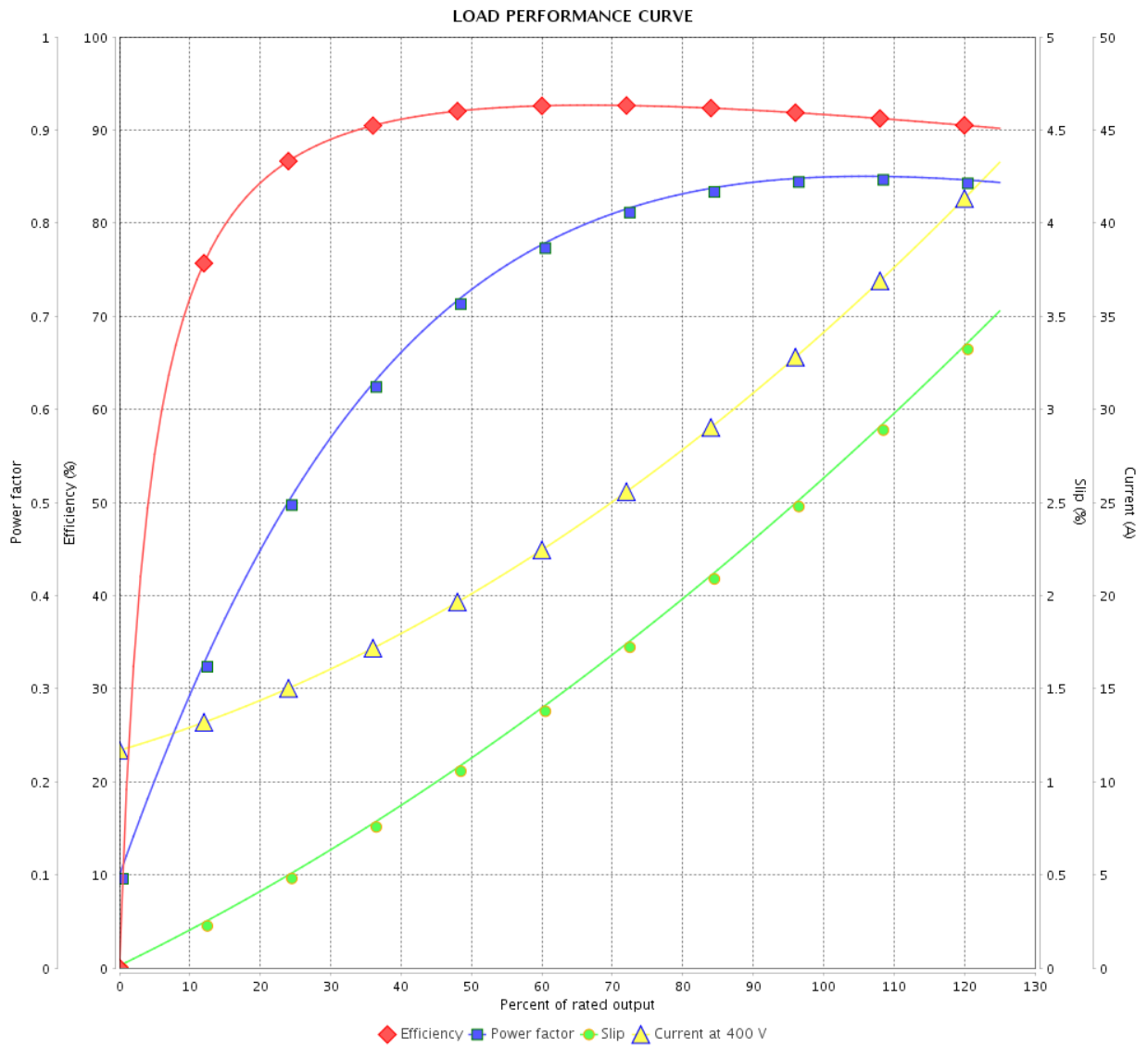

Performance : 400 V 50 Hz 4P IE2

Rated current : 34.8 A
 LRC : 7.1
 Rated torque : 89.9 ft.lb
 Locked rotor torque : 240 %
 Breakdown torque : 250 %
 Rated speed : 1465 rpm

Moment of inertia (J) : 4.54 sq.ft.lb
 Duty cycle : Cont.(S1)
 Insulation class : F
 Service factor : 1.00
 Temperature rise : 80 K
 Design : B

Rev.	Changes Summary	Performed	Checked	Date
Performed by		Page		Revision
Checked by		9 / 22		
Date		13/04/2022		

LOAD PERFORMANCE CURVE

Three Phase Induction Motor - Squirrel Cage



Customer :

Product line : NEMA Premium Efficiency Three-Phase
 Product code : 14407648
 Catalog # : 02518XT3ER284TC

LOAD PERFORMANCE CURVE

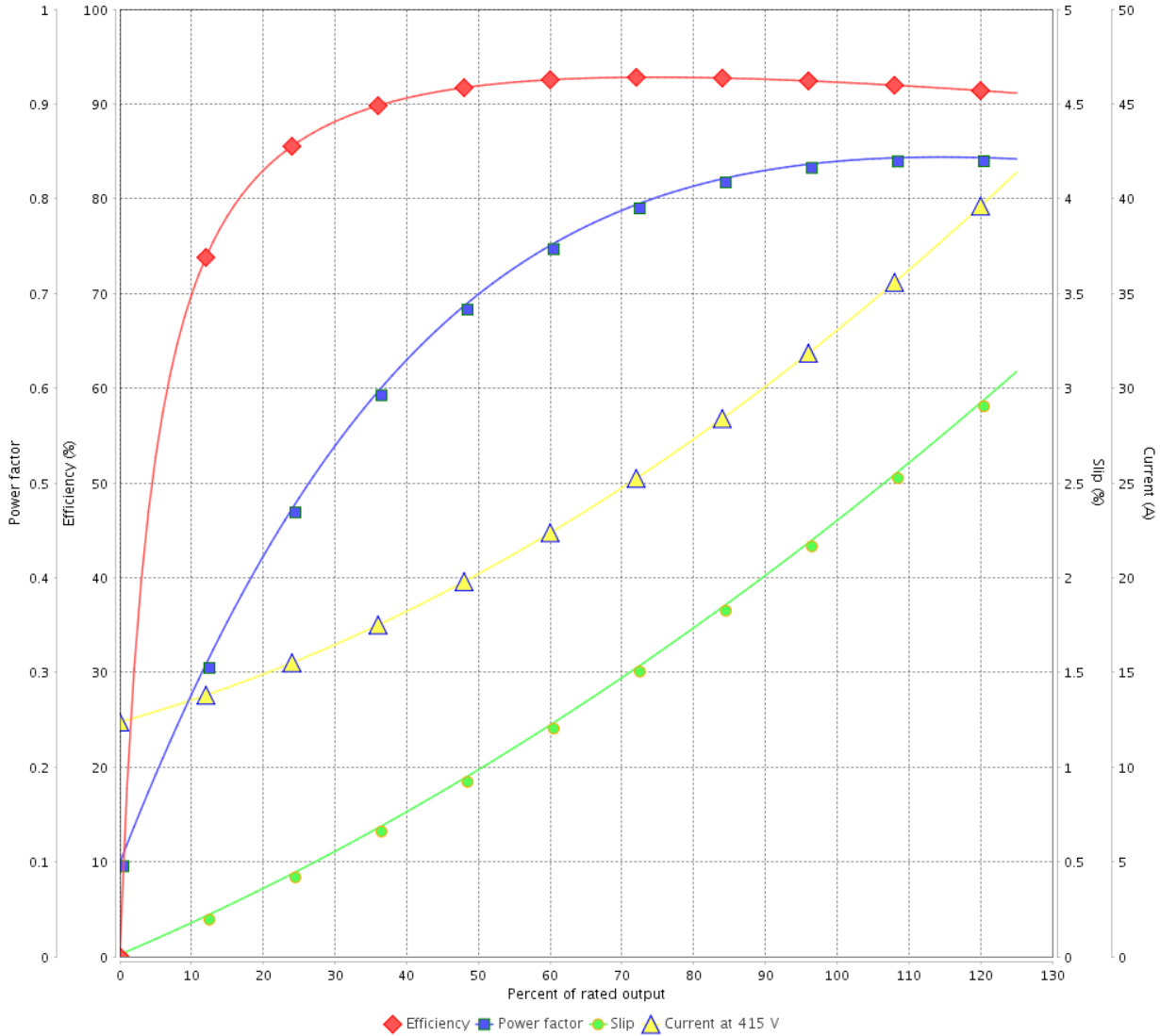

Performance : 415 V 50 Hz 4P IE2

Rated current	: 34.0 A	Moment of inertia (J)	: 4.54 sq.ft.lb
LRC	: 7.6	Duty cycle	: Cont.(S1)
Rated torque	: 89.6 ft.lb	Insulation class	: F
Locked rotor torque	: 260 %	Service factor	: 1.00
Breakdown torque	: 270 %	Temperature rise	: 80 K
Rated speed	: 1470 rpm	Design	: B

Rev.	Changes Summary	Performed	Checked	Date
Performed by			Page	Revision
Checked by			10 / 22	
Date	13/04/2022			

THERMAL LIMIT CURVE



Three Phase Induction Motor - Squirrel Cage

Customer :

Product line : NEMA Premium Efficiency Three-Phase
 Product code : 14407648
 Catalog # : 02518XT3ER284TC

Performance : 230/460 V 60 Hz 4P

Rated current : 59.8/29.9 A	Moment of inertia (J) : 4.54 sq.ft.lb
LRC : 8.2	Duty cycle : Cont.(S1)
Rated torque : 74.2 ft.lb	Insulation class : F
Locked rotor torque : 320 %	Service factor : 1.15
Breakdown torque : 320 %	Temperature rise : 80 K
Rated speed : 1770 rpm	Design : B

Heating constant

Cooling constant

Rev.	Changes Summary	Performed	Checked	Date
Performed by			Page 11 / 22	Revision
Checked by				
Date	13/04/2022			

THERMAL LIMIT CURVE

Three Phase Induction Motor - Squirrel Cage



Customer : _____

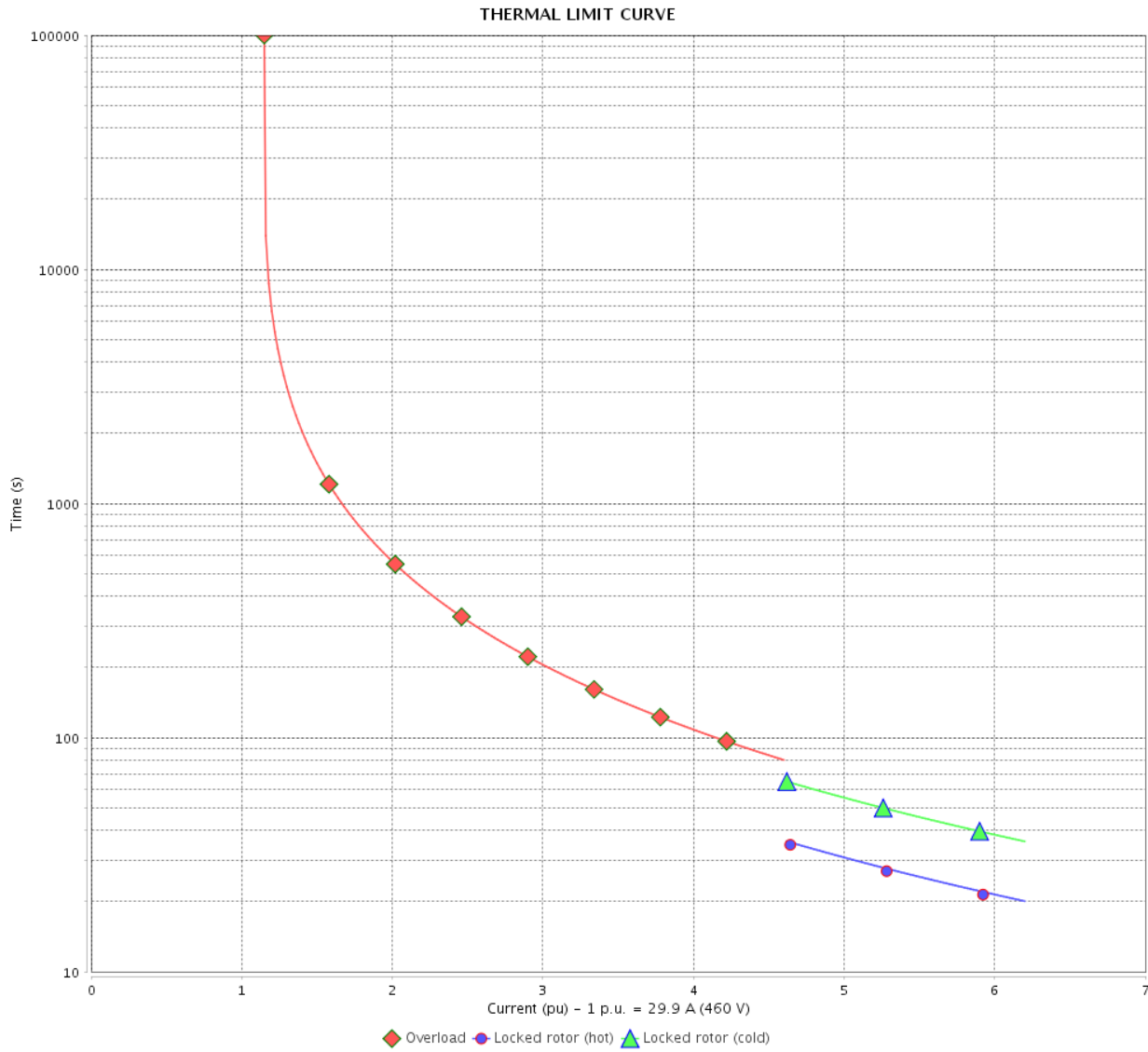

Rev.	Changes Summary	Performed	Checked	Date
Performed by		Page		Revision
Checked by		12 / 22		
Date		13/04/2022		

THERMAL LIMIT CURVE



Three Phase Induction Motor - Squirrel Cage

Customer :

Product line : NEMA Premium Efficiency Three-Phase
 Product code : 14407648
 Catalog # : 02518XT3ER284TC

Performance : 380 V 50 Hz 4P IE2

Rated current : 36.5 A	Moment of inertia (J) : 4.54 sq.ft.lb
LRC : 6.4	Duty cycle : Cont.(S1)
Rated torque : 90.2 ft.lb	Insulation class : F
Locked rotor torque : 229 %	Service factor : 1.00
Breakdown torque : 240 %	Temperature rise : 80 K
Rated speed : 1460 rpm	Design : B

Heating constant

Cooling constant

Rev.	Changes Summary	Performed	Checked	Date
Performed by			Page 13 / 22	Revision
Checked by				
Date	13/04/2022			

THERMAL LIMIT CURVE

Three Phase Induction Motor - Squirrel Cage



Customer : _____

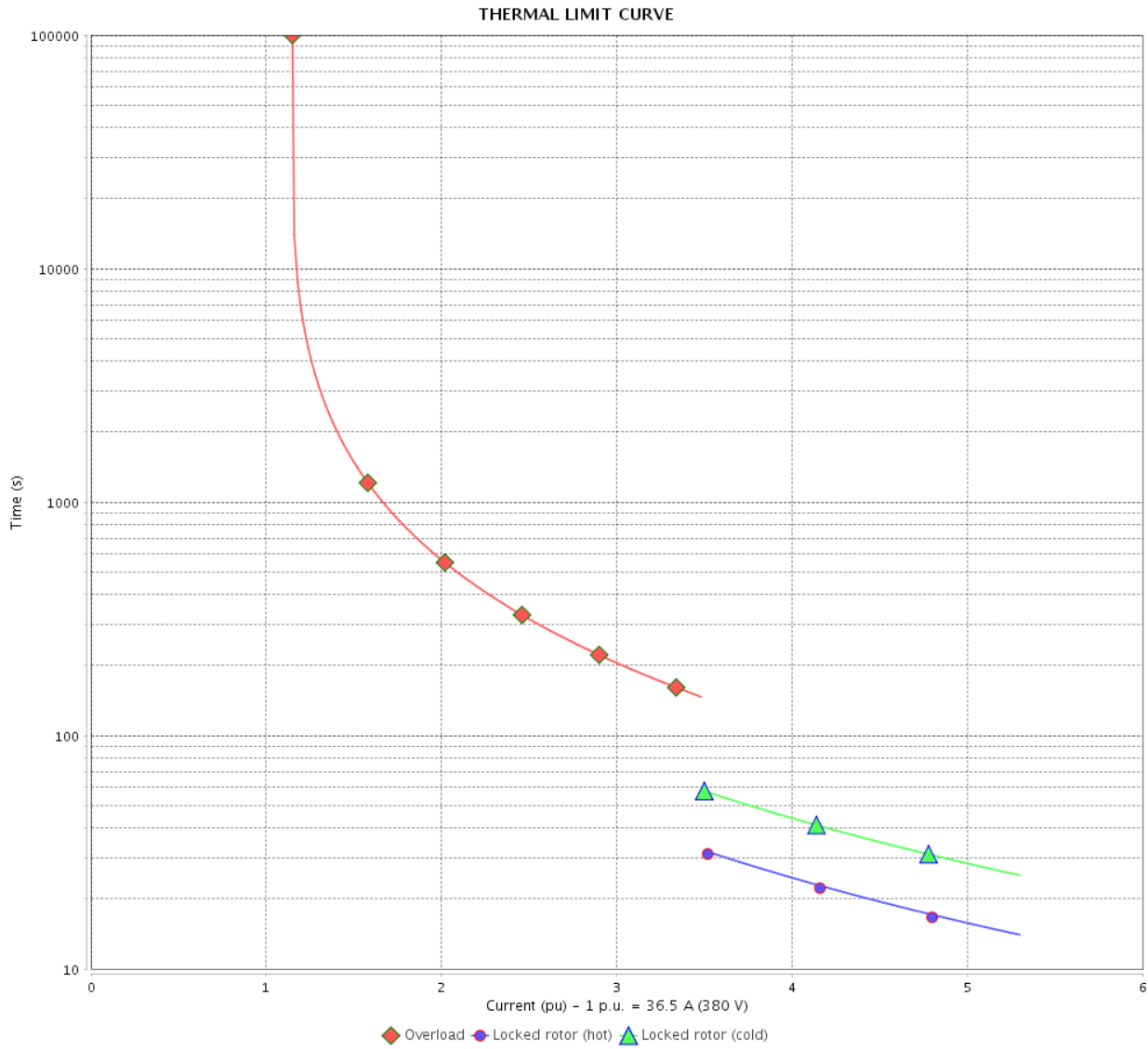

Rev.	Changes Summary	Performed	Checked	Date
Performed by				
Checked by				
Date				
			Page	Revision
			14 / 22	

THERMAL LIMIT CURVE

Three Phase Induction Motor - Squirrel Cage



Customer :

Product line : NEMA Premium Efficiency Three-Phase

Product code : 14407648

Catalog # : 02518XT3ER284TC

Performance : 400 V 50 Hz 4P IE2

Rated current : 34.8 A
LRC : 7.1
Rated torque : 89.9 ft.lb
Locked rotor torque : 240 %
Breakdown torque : 250 %
Rated speed : 1465 rpm

Moment of inertia (J) : 4.54 sq.ft.lb
Duty cycle : Cont.(S1)
Insulation class : F
Service factor : 1.00
Temperature rise : 80 K
Design : B

Heating constant

Cooling constant

Rev.	Changes Summary	Performed	Checked	Date
Performed by				
Checked by			Page	Revision
Date	13/04/2022		15 / 22	

THERMAL LIMIT CURVE

Three Phase Induction Motor - Squirrel Cage



Customer : _____

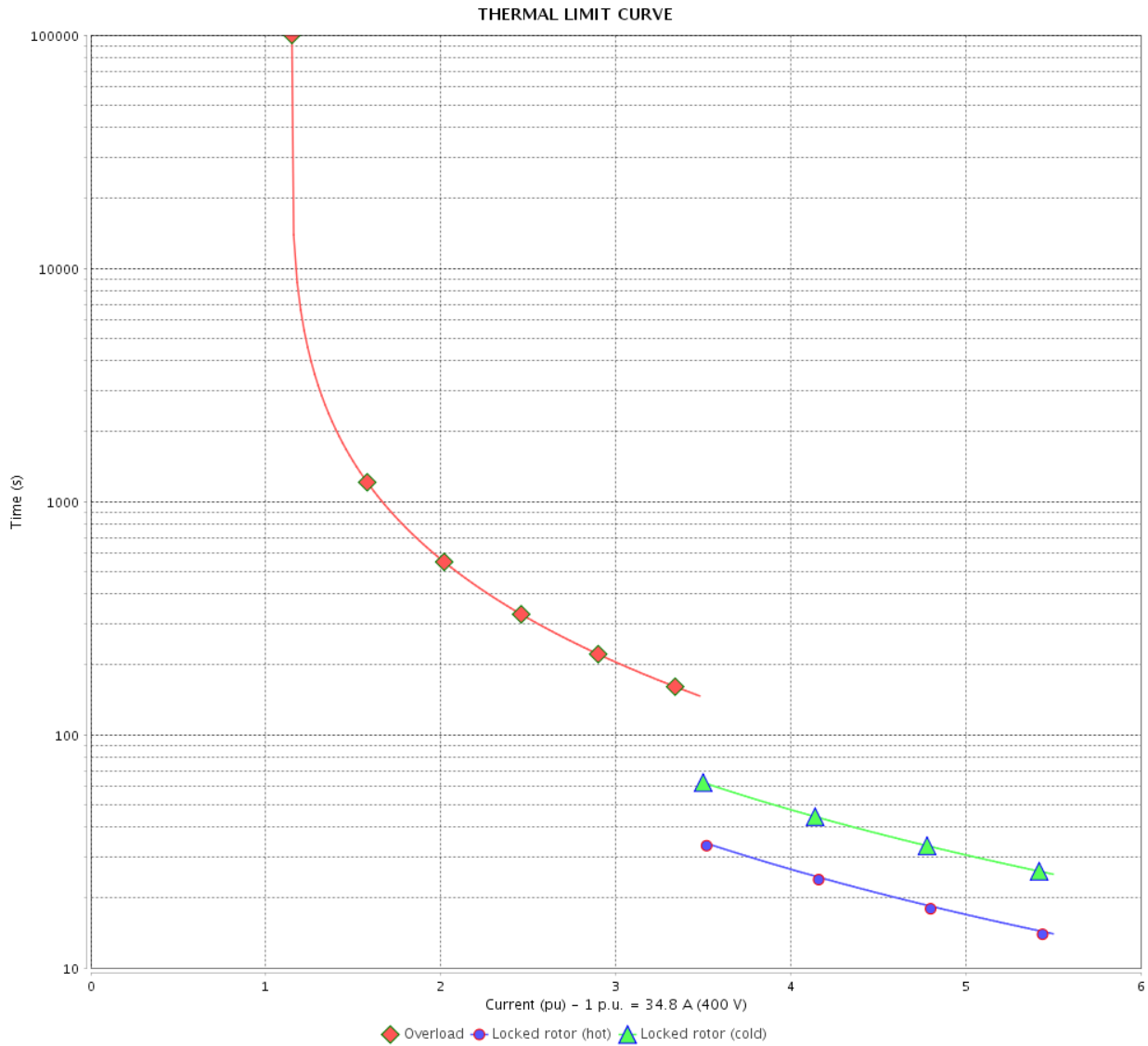

Rev.	Changes Summary	Performed	Checked	Date
Performed by		Page 16 / 22		Revision
Checked by				
Date				

THERMAL LIMIT CURVE



Three Phase Induction Motor - Squirrel Cage

Customer :

Product line : NEMA Premium Efficiency Three-Phase
 Product code : 14407648
 Catalog # : 02518XT3ER284TC

Performance : 415 V 50 Hz 4P IE2

Rated current : 34.0 A	Moment of inertia (J) : 4.54 sq.ft.lb
LRC : 7.6	Duty cycle : Cont.(S1)
Rated torque : 89.6 ft.lb	Insulation class : F
Locked rotor torque : 260 %	Service factor : 1.00
Breakdown torque : 270 %	Temperature rise : 80 K
Rated speed : 1470 rpm	Design : B

Heating constant

Cooling constant

Rev.	Changes Summary	Performed	Checked	Date
Performed by			Page 17 / 22	Revision
Checked by				
Date	13/04/2022			

THERMAL LIMIT CURVE

Three Phase Induction Motor - Squirrel Cage



Customer : _____

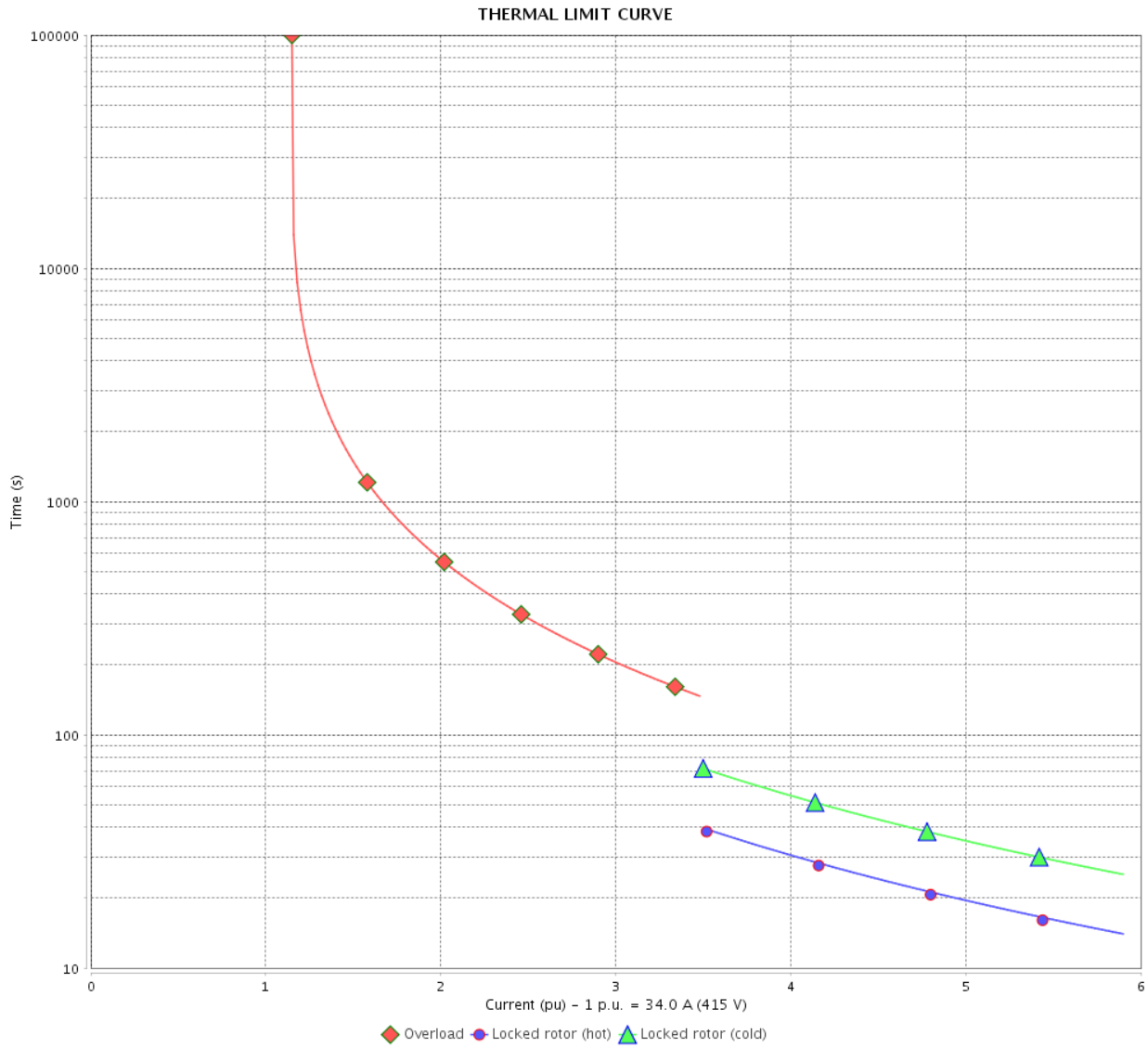

Rev.	Changes Summary	Performed	Checked	Date
Performed by		Page 18 / 22		Revision
Checked by				
Date				

VFD OPERATION CURVE

Three Phase Induction Motor - Squirrel Cage



Customer :

Product line : NEMA Premium Efficiency Three-Phase

Product code : 14407648

Catalog # : 02518XT3ER284TC

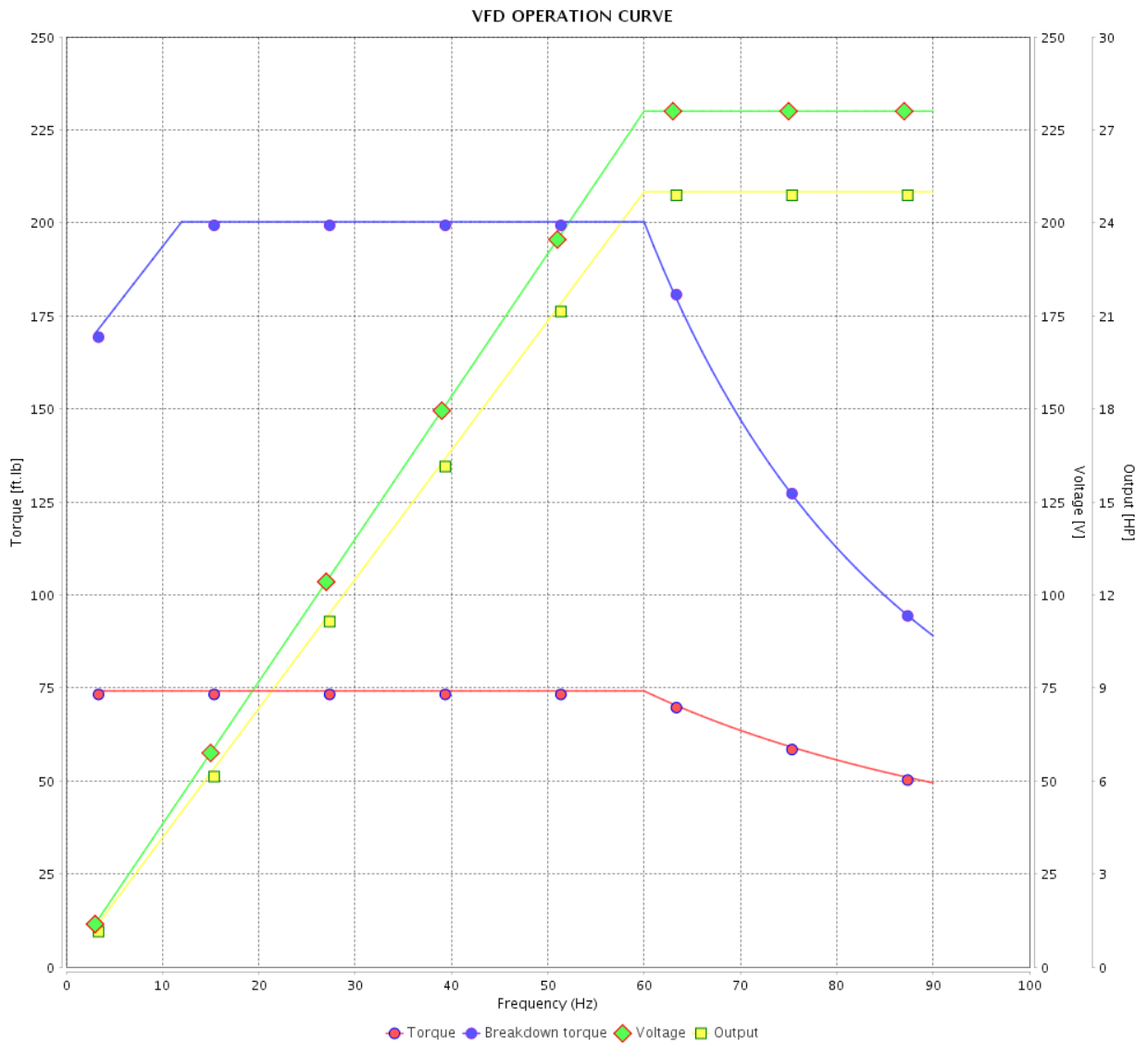

Performance : 230/460 V 60 Hz 4P

Rated current : 59.8/29.9 A
 LRC : 8.2
 Rated torque : 74.2 ft.lb
 Locked rotor torque : 320 %
 Breakdown torque : 320 %
 Rated speed : 1770 rpm

Moment of inertia (J) : 4.54 sq.ft.lb
 Duty cycle : Cont.(S1)
 Insulation class : F
 Service factor : 1.15
 Temperature rise : 80 K
 Design : B

Rev.	Changes Summary	Performed	Checked	Date
Performed by			Page 19 / 22	Revision
Checked by				
Date	13/04/2022			

VFD OPERATION CURVE

Three Phase Induction Motor - Squirrel Cage



Customer :

Product line : NEMA Premium Efficiency Three-Phase

Product code : 14407648

Catalog # : 02518XT3ER284TC

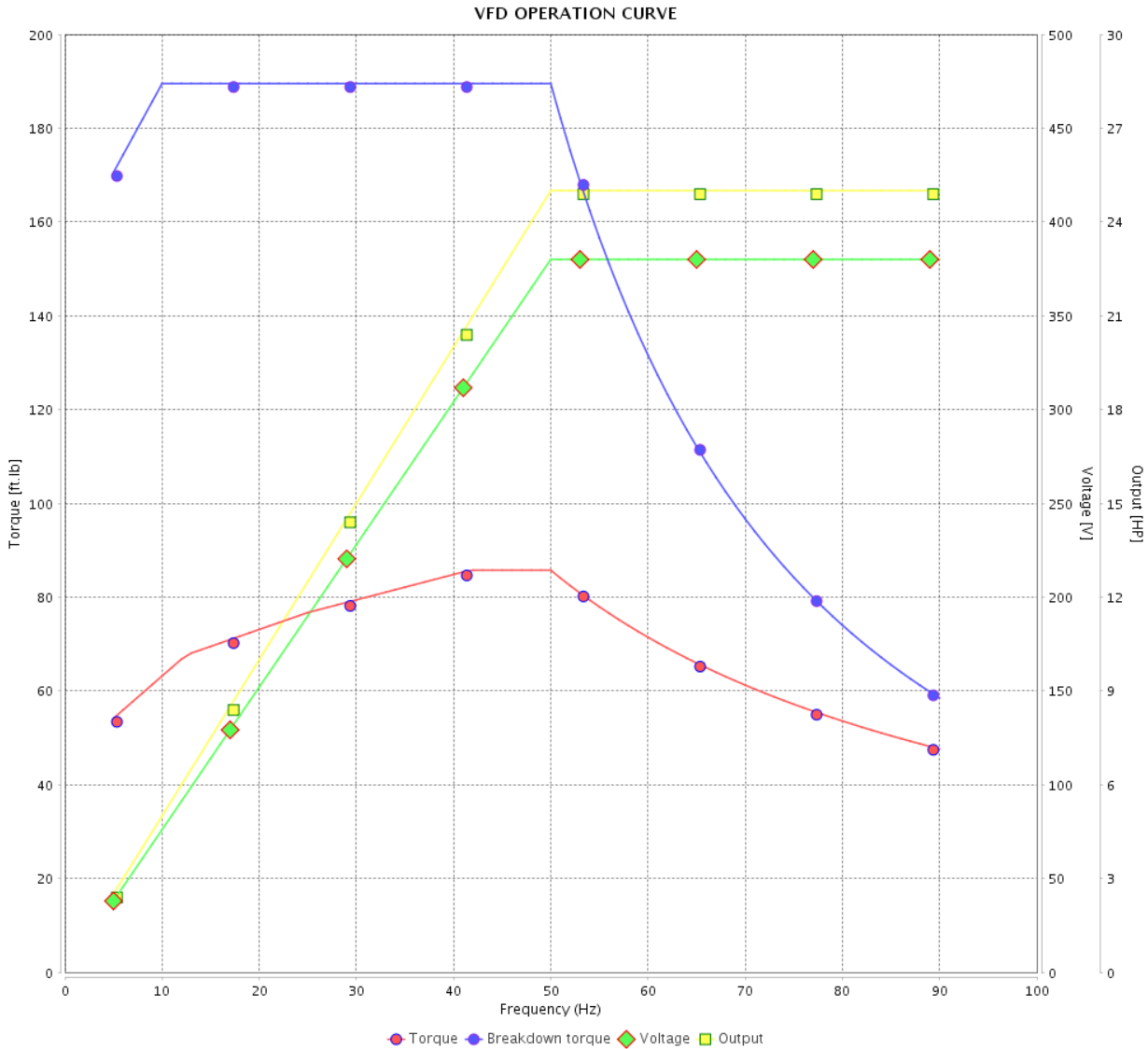

Performance : 380 V 50 Hz 4P IE2

Rated current : 36.5 A
 LRC : 6.4
 Rated torque : 90.2 ft.lb
 Locked rotor torque : 229 %
 Breakdown torque : 240 %
 Rated speed : 1460 rpm

Moment of inertia (J) : 4.54 sq.ft.lb
 Duty cycle : Cont.(S1)
 Insulation class : F
 Service factor : 1.00
 Temperature rise : 80 K
 Design : B

Rev.	Changes Summary	Performed	Checked	Date
Performed by			Page	Revision
Checked by				
Date				

VFD OPERATION CURVE

Three Phase Induction Motor - Squirrel Cage



Customer :

Product line : NEMA Premium Efficiency Three-Phase

Product code : 14407648

Catalog # : 02518XT3ER284TC

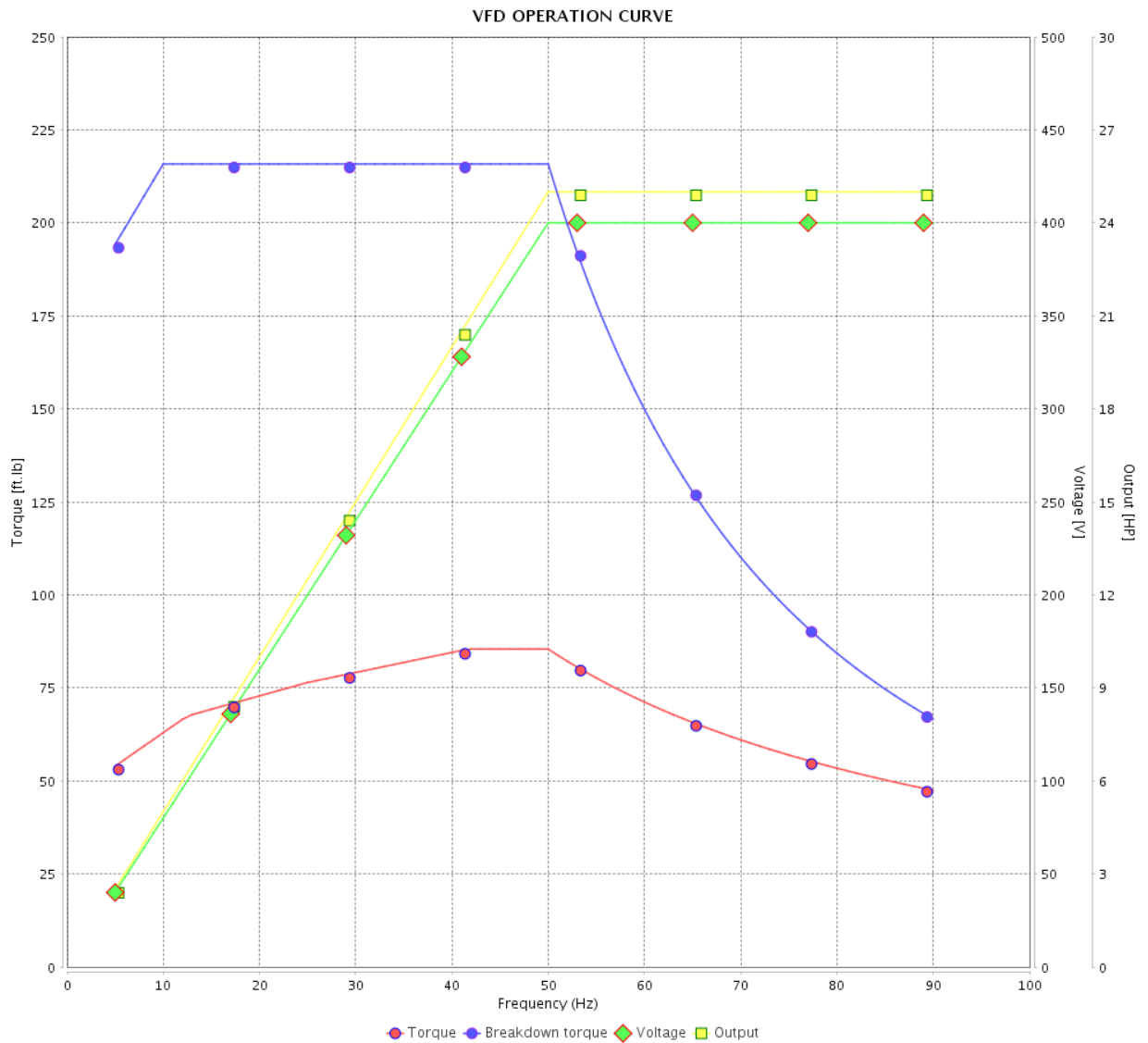

Performance : 400 V 50 Hz 4P IE2

Rated current : 34.8 A
 LRC : 7.1
 Rated torque : 89.9 ft.lb
 Locked rotor torque : 240 %
 Breakdown torque : 250 %
 Rated speed : 1465 rpm

Moment of inertia (J) : 4.54 sq.ft.lb
 Duty cycle : Cont.(S1)
 Insulation class : F
 Service factor : 1.00
 Temperature rise : 80 K
 Design : B

Rev.	Changes Summary	Performed	Checked	Date
Performed by			Page 21 / 22	Revision
Checked by				
Date	13/04/2022			

VFD OPERATION CURVE

Three Phase Induction Motor - Squirrel Cage



Customer :

Product line : NEMA Premium Efficiency Three-Phase

Product code : 14407648

Catalog # : 02518XT3ER284TC

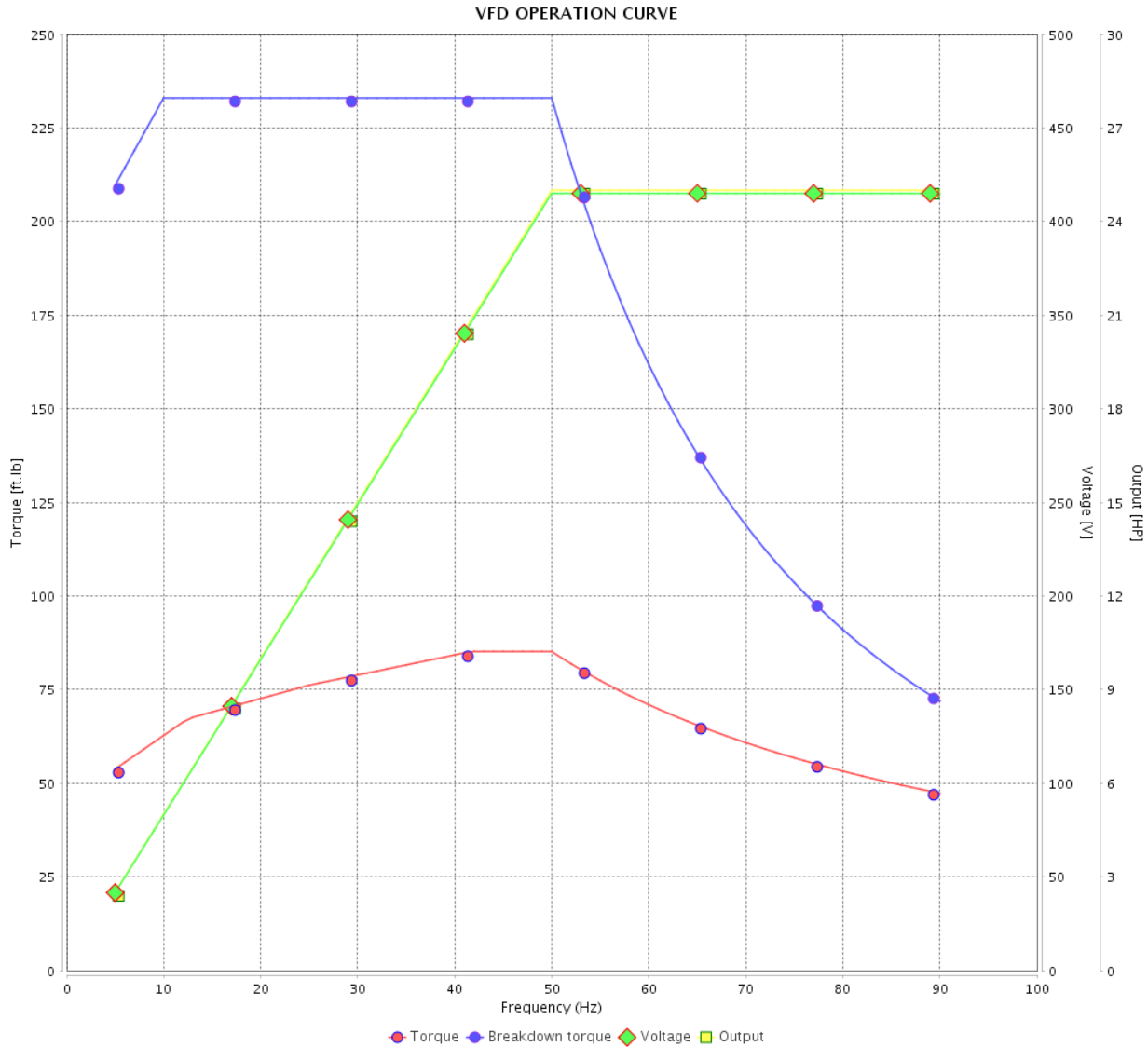

Performance : 415 V 50 Hz 4P IE2

Rated current : 34.0 A
 LRC : 7.6
 Rated torque : 89.6 ft.lb
 Locked rotor torque : 260 %
 Breakdown torque : 270 %
 Rated speed : 1470 rpm

Moment of inertia (J) : 4.54 sq.ft.lb
 Duty cycle : Cont.(S1)
 Insulation class : F
 Service factor : 1.00
 Temperature rise : 80 K
 Design : B

Rev.	Changes Summary	Performed	Checked	Date
Performed by			Page 22 / 22	Revision
Checked by				
Date	13/04/2022			

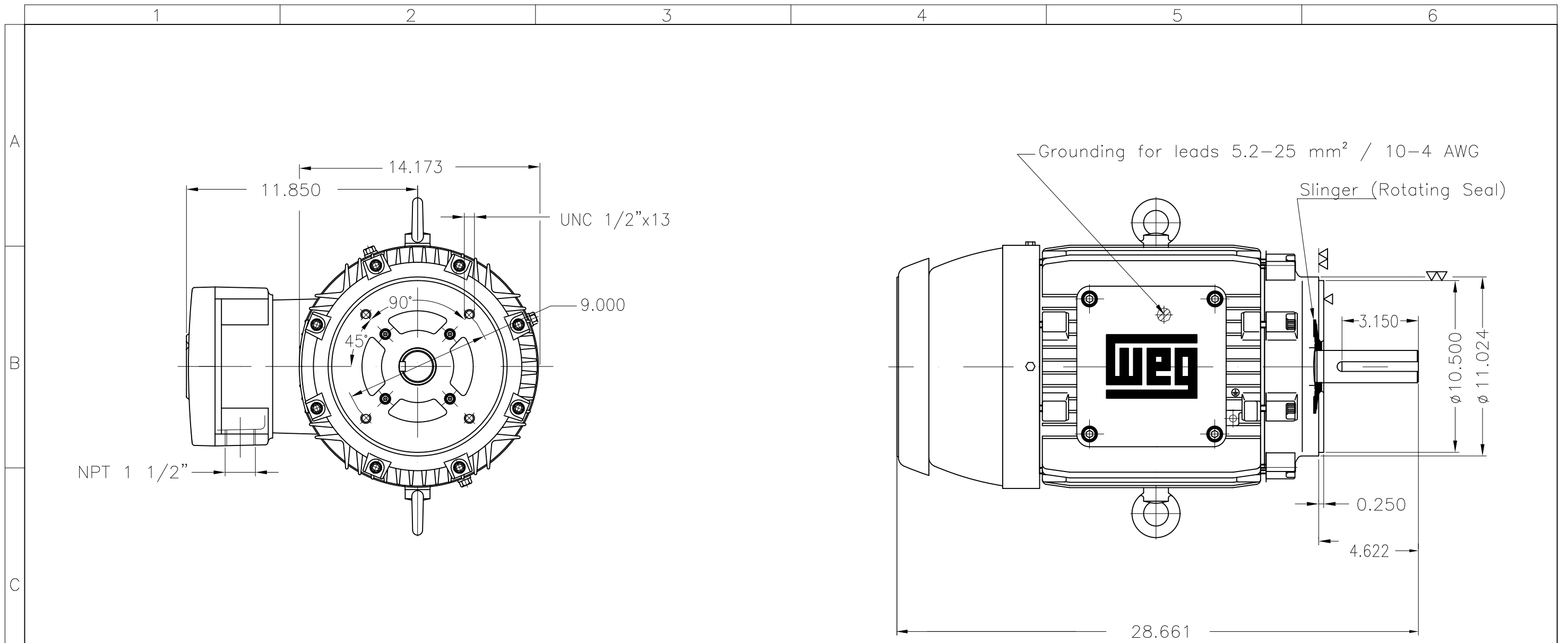

A

B

C

D

E

- With grease fitting
- Color RAL 5009
- Painting plan 202P
- Mounting NEMA W-6
- Mounting V18

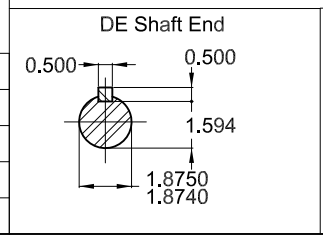

25 HP 04 Poles 60 Hz A

ECM	LOC	SUMMARY OF MODIFICATIONS	EXECUTED	CHECKED	RELEASED	DATE	VER
EXECUTED	PIRWBUSER	THREE PH. MOTOR EXPLOSION PROOF PREM. EFF.					
CHECKED		FRAME 284TC IP55 TEFC					
RELEASED							
REL DT.	WMO	Jaragua do Sul	Product Engineering	SHEET	1 / 1		

PREVIEW

WDD

MADE IN BRAZIL

W21X NEMA
Premium

14407648



LISTED

CC029A

Inverter Duty Motor
Severe Duty

MODEL 02518XT3ER284TC

PH 3 FR 284TC

HP(kW) 25.0(18.5)

HZ 60

IP55

V 230/460

A 59.8/29.9

RPM 1770

NEMA NOM EFF 93.6%

PF 0.83

SFA 68.8/34.4

DES B

INS CL F ΔT 80 K SF 1.15

ENCL TEFC

DUTY CONT.

CODE J

ALT 1000

m.a.s.l.

AMB 40°C

USABLE @208V

64.5 A

SF 1.15

SFA 74.2

AMB 55°C SF1.0

25HP 18.5kW 50Hz 380V 36.5A 1460RPM SF1.00 EFF 91.7% (IE2)

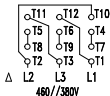
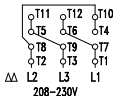

→ 6311-C3 MOBIL POLYREX EM

→ 6211-C3 18 g 12213 h

485 Lbs

 TEMP CODE T3C
 CSA/UL: Class I - Div. 1 - Groups C and D
 CSA: Class II - Div. 1 - Groups F and G
 CSA: Class I - Zone 1 - IIB

EXPLOSION PROOF MOTOR

FOR USE ON VPWM VFD 1000:1VT, 6:1CT, 1.0SF, T3C, AMB 40°C.