

# DATA SHEET



## Three Phase Induction Motor - Squirrel Cage

Customer :																			
Product line	: NEMA Premium Efficiency Three-Phase																		
Product code :	12447105																		
Catalog # :	02536ET3H284TSC-W22																		
Frame : 284/6TSC Output : 25 HP (18.5 kW) Poles : 2 Frequency : 60 Hz Rated voltage : 575 V Rated current : 23.0 A L. R. Amperes : 145 A LRC : 6.3x(Code G) No load current : 6.40 A Rated speed : 3545 rpm Slip : 1.53 % Rated torque : 37.1 ft.lb Locked rotor torque : 200 % Breakdown torque : 250 % Insulation class : F Service factor : 1.25 Moment of inertia (J) : 2.69 sq.ft.lb Design : B	Locked rotor time : 30s (cold) 17s (hot) Temperature rise : 80 K Duty cycle : Cont.(S1) Ambient temperature : -20°C to +40°C Altitude : 1000 m.a.s.l. Protection degree : IP55 Cooling method : IC411 - TEFC Mounting : F-1 Rotation <sup>1</sup> : Both (CW and CCW) Noise level <sup>2</sup> : 72.0 dB(A) Starting method : Direct On Line Approx. weight <sup>3</sup> : 402 lb																		
Output	25%    50%    75%    100%																		
Efficiency (%)	90.8    91.0    91.7    91.7																		
Power Factor	0.55    0.79    0.86    0.88																		
Foundation loads																			
Max. traction : 202 lb																			
Max. compression : 604 lb																			
	<table border="0"> <tr> <td></td> <td style="text-align: center;"><u>Drive end</u></td> <td style="text-align: center;"><u>Non drive end</u></td> </tr> <tr> <td>Bearing type :</td> <td style="text-align: center;">6311 C3</td> <td style="text-align: center;">6211 C3</td> </tr> <tr> <td>Sealing :</td> <td style="text-align: center;">V'Ring</td> <td style="text-align: center;">V'Ring</td> </tr> <tr> <td>Lubrication interval :</td> <td style="text-align: center;">14000 h</td> <td style="text-align: center;">17000 h</td> </tr> <tr> <td>Lubricant amount :</td> <td style="text-align: center;">18 g</td> <td style="text-align: center;">11 g</td> </tr> <tr> <td>Lubricant type :</td> <td colspan="2" style="text-align: center;">Mobil Polyrex EM</td> </tr> </table>		<u>Drive end</u>	<u>Non drive end</u>	Bearing type :	6311 C3	6211 C3	Sealing :	V'Ring	V'Ring	Lubrication interval :	14000 h	17000 h	Lubricant amount :	18 g	11 g	Lubricant type :	Mobil Polyrex EM	
	<u>Drive end</u>	<u>Non drive end</u>																	
Bearing type :	6311 C3	6211 C3																	
Sealing :	V'Ring	V'Ring																	
Lubrication interval :	14000 h	17000 h																	
Lubricant amount :	18 g	11 g																	
Lubricant type :	Mobil Polyrex EM																		
Notes																			
This revision replaces and cancel the previous one, which must be eliminated. (1) Looking the motor from the shaft end. (2) Measured at 1m and with tolerance of +3dB(A). (3) Approximate weight subject to changes after manufacturing process. (4) At 100% of full load.																			
These are average values based on tests with sinusoidal power supply, subject to the tolerances stipulated in NEMA MG-1.																			
Rev.	Changes Summary	Performed	Checked	Date															
Performed by																			
Checked by			Page	Revision															
Date	14/04/2022		1 / 6																

# TORQUE AND CURRENT VS SPEED CURVE

Three Phase Induction Motor - Squirrel Cage



Customer :

Product line : NEMA Premium Efficiency Three-Phase

Product code : 12447105

Catalog # : 02536ET3H284TSC-W22

TORQUE AND CURRENT VS SPEED CURVE

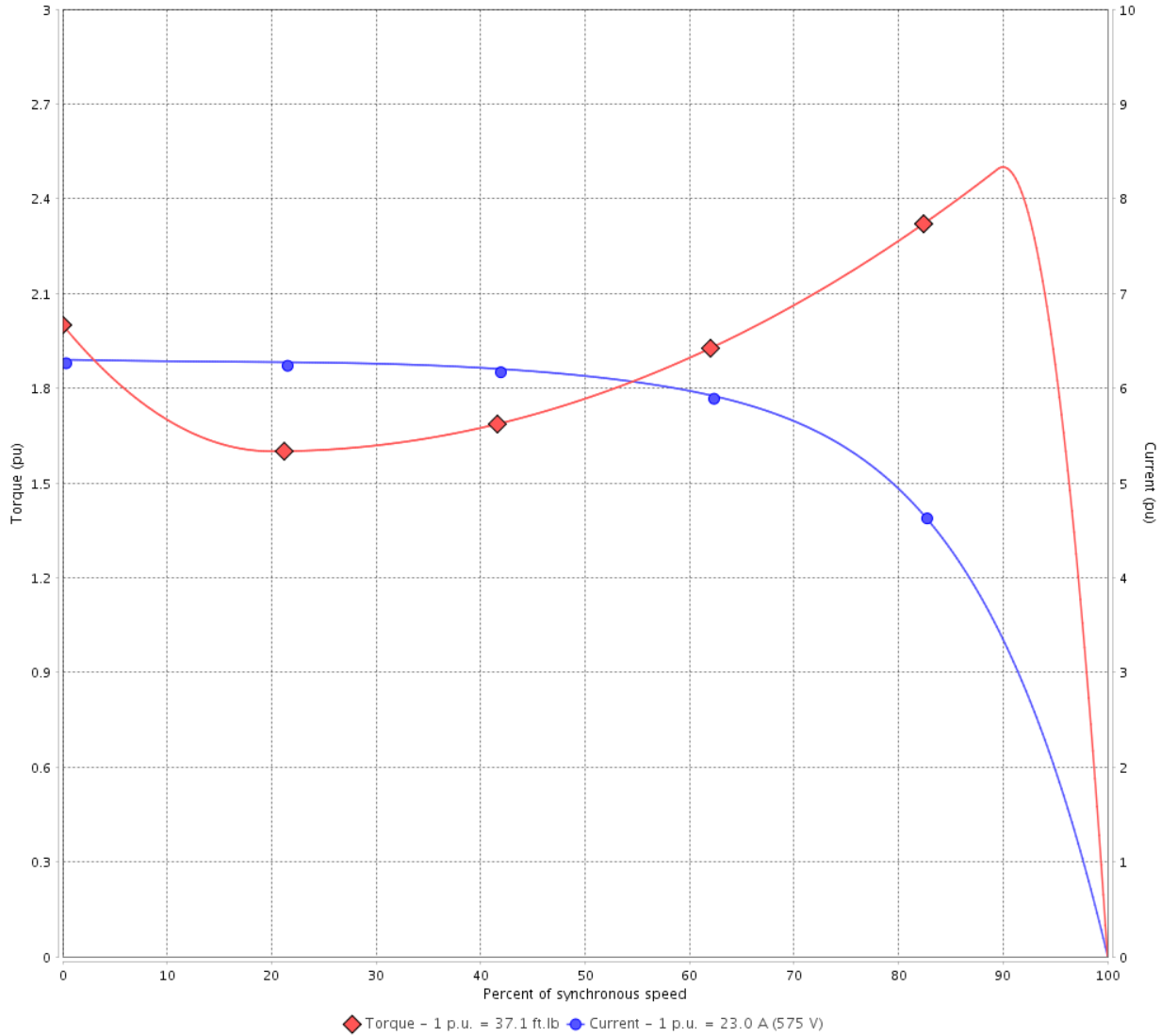

Performance : 575 V 60 Hz 2P

Rated current	: 23.0 A	Moment of inertia (J)	: 2.69 sq.ft.lb
LRC	: 6.3	Duty cycle	: Cont.(S1)
Rated torque	: 37.1 ft.lb	Insulation class	: F
Locked rotor torque	: 200 %	Service factor	: 1.25
Breakdown torque	: 250 %	Temperature rise	: 80 K
Rated speed	: 3545 rpm	Design	: B

Locked rotor time : 30s (cold) 17s (hot)

Rev.	Changes Summary	Performed	Checked	Date
Performed by			Page 2 / 6	Revision
Checked by				
Date	14/04/2022			

# LOAD PERFORMANCE CURVE

## Three Phase Induction Motor - Squirrel Cage



Customer :

Product line : NEMA Premium Efficiency Three-Phase

Product code : 12447105

Catalog # : 02536ET3H284TSC-W22

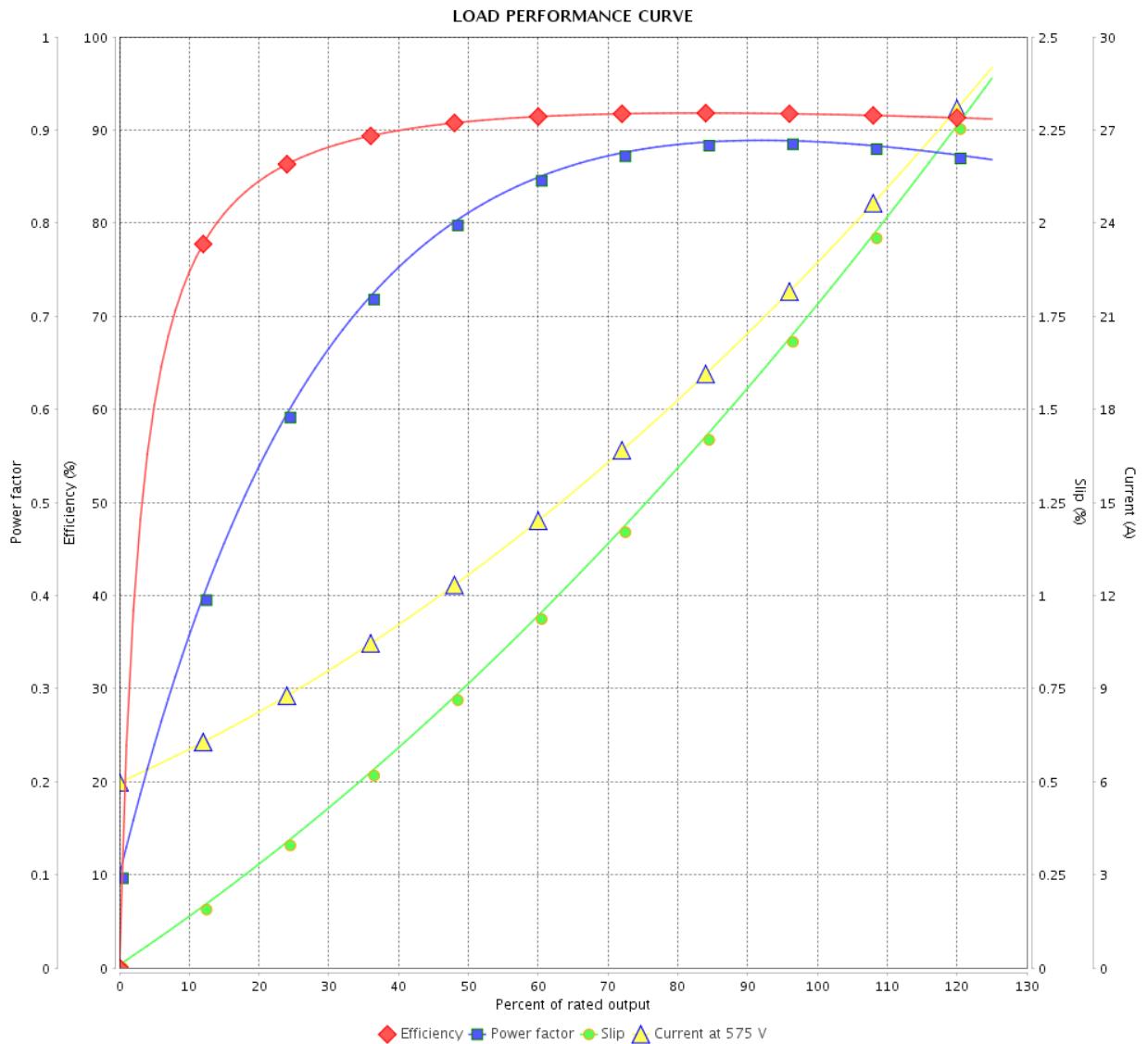

Performance : 575 V 60 Hz 2P

Rated current : 23.0 A  
 LRC : 6.3  
 Rated torque : 37.1 ft.lb  
 Locked rotor torque : 200 %  
 Breakdown torque : 250 %  
 Rated speed : 3545 rpm

Moment of inertia (J) : 2.69 sq.ft.lb  
 Duty cycle : Cont.(S1)  
 Insulation class : F  
 Service factor : 1.25  
 Temperature rise : 80 K  
 Design : B

Rev.	Changes Summary	Performed	Checked	Date
Performed by			Page	Revision
Checked by				
Date				
			3 / 6	

# THERMAL LIMIT CURVE

## Three Phase Induction Motor - Squirrel Cage



Customer :

Product line : NEMA Premium Efficiency Three-Phase  
Product code : 12447105  
Catalog # : 02536ET3H284TSC-W22

Performance : 575 V 60 Hz 2P

Rated current	: 23.0 A	Moment of inertia (J)	: 2.69 sq.ft.lb
LRC	: 6.3	Duty cycle	: Cont.(S1)
Rated torque	: 37.1 ft.lb	Insulation class	: F
Locked rotor torque	: 200 %	Service factor	: 1.25
Breakdown torque	: 250 %	Temperature rise	: 80 K
Rated speed	: 3545 rpm	Design	: B

Heating constant

Cooling constant

Rev.	Changes Summary	Performed	Checked	Date
Performed by				
Checked by			Page	Revision
Date	14/04/2022		4 / 6	

# THERMAL LIMIT CURVE

Three Phase Induction Motor - Squirrel Cage



Customer : \_\_\_\_\_

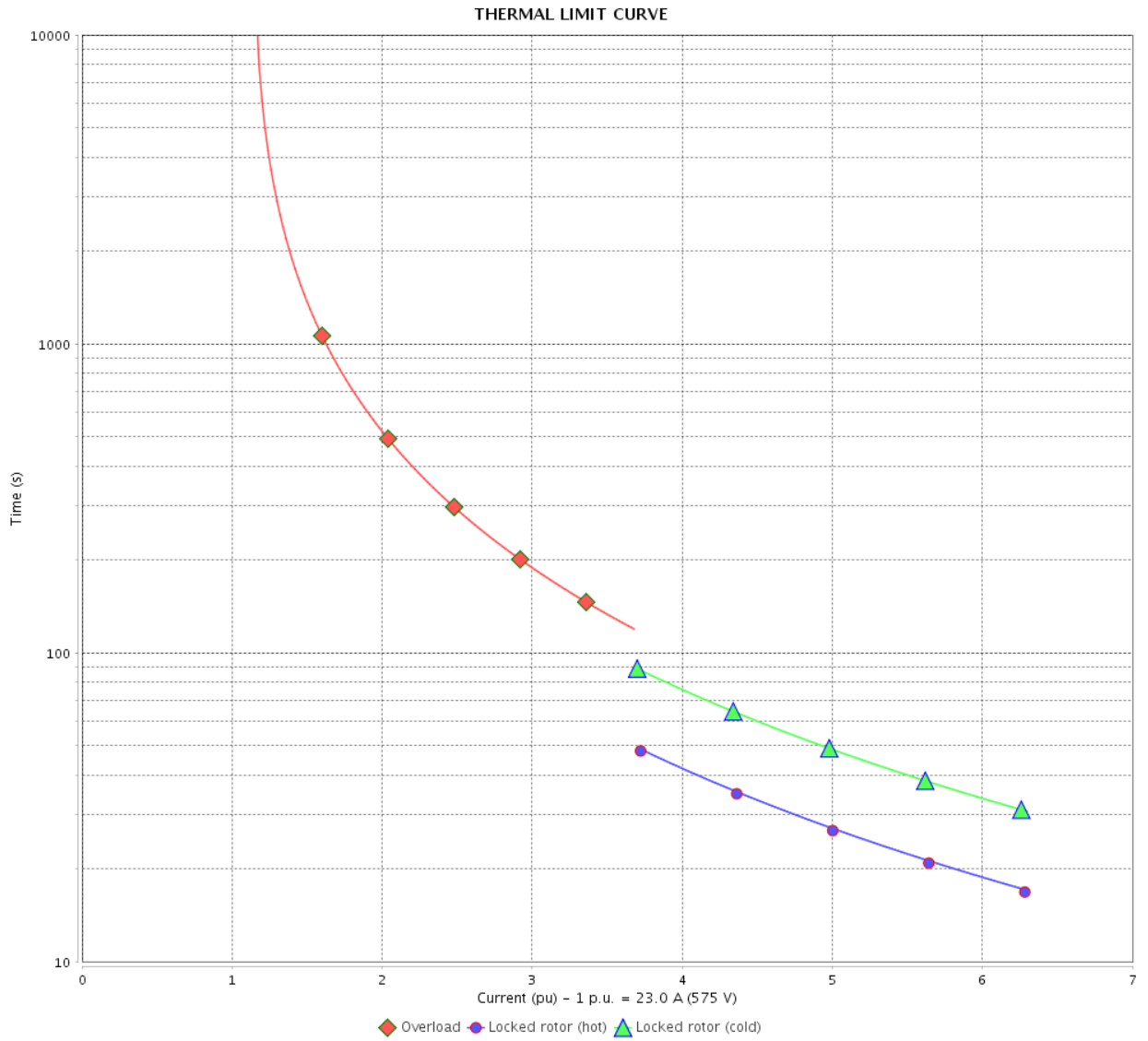

Rev.	Changes Summary	Performed	Checked	Date
Performed by		Page		Revision
Checked by		5 / 6		
Date		14/04/2022		

# VFD OPERATION CURVE

Three Phase Induction Motor - Squirrel Cage



Customer :

Product line : NEMA Premium Efficiency Three-Phase

Product code : 12447105

Catalog # : 02536ET3H284TSC-W22

VFD OPERATION CURVE

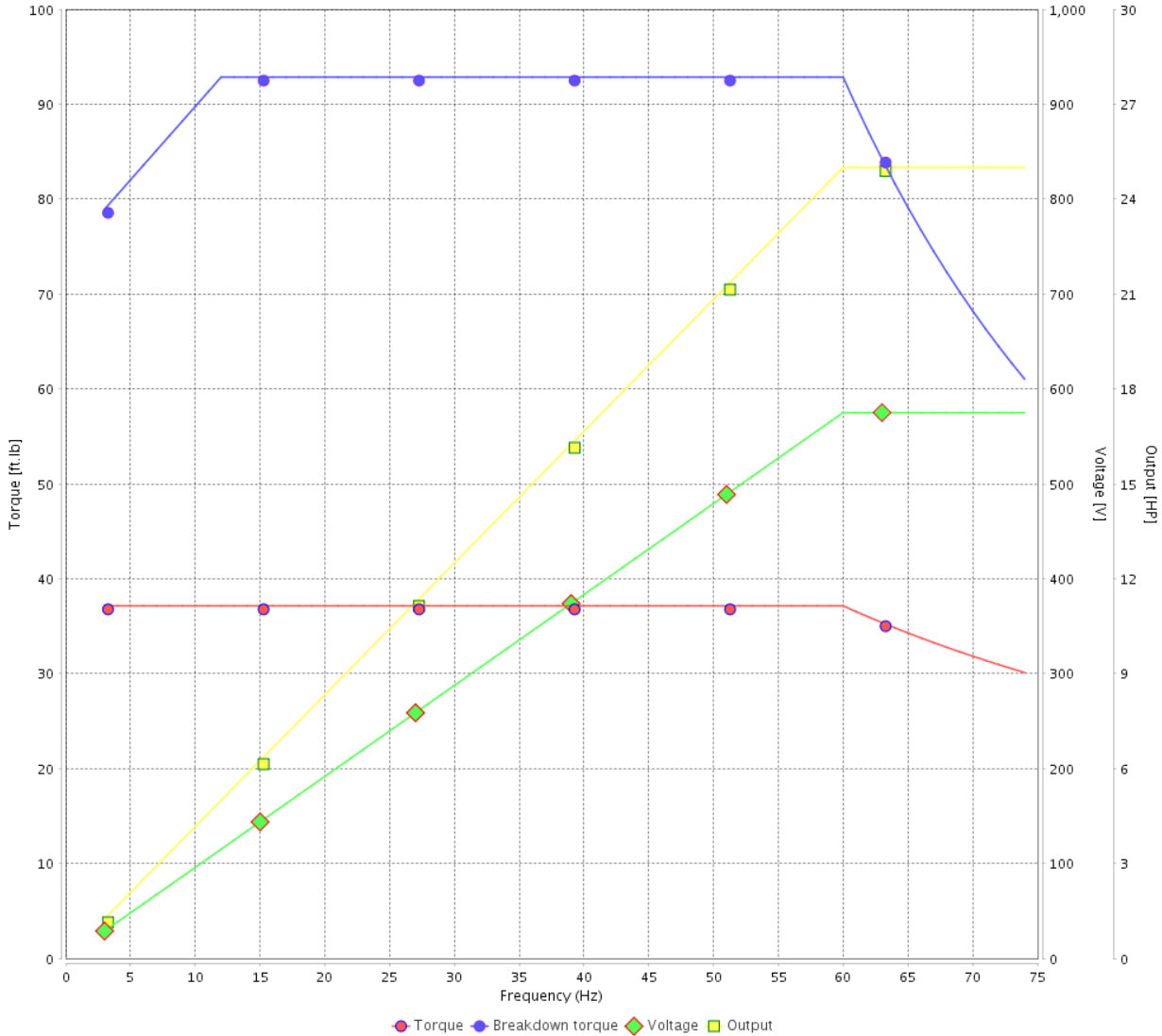

Performance : 575 V 60 Hz 2P

Rated current : 23.0 A  
 LRC : 6.3  
 Rated torque : 37.1 ft.lb  
 Locked rotor torque : 200 %  
 Breakdown torque : 250 %  
 Rated speed : 3545 rpm

Moment of inertia (J) : 2.69 sq.ft.lb  
 Duty cycle : Cont.(S1)  
 Insulation class : F  
 Service factor : 1.25  
 Temperature rise : 80 K  
 Design : B

Rev.	Changes Summary	Performed	Checked	Date
Performed by			Page 6 / 6	Revision
Checked by				
Date	14/04/2022			

1 2 3 4 5 6

A

B

C

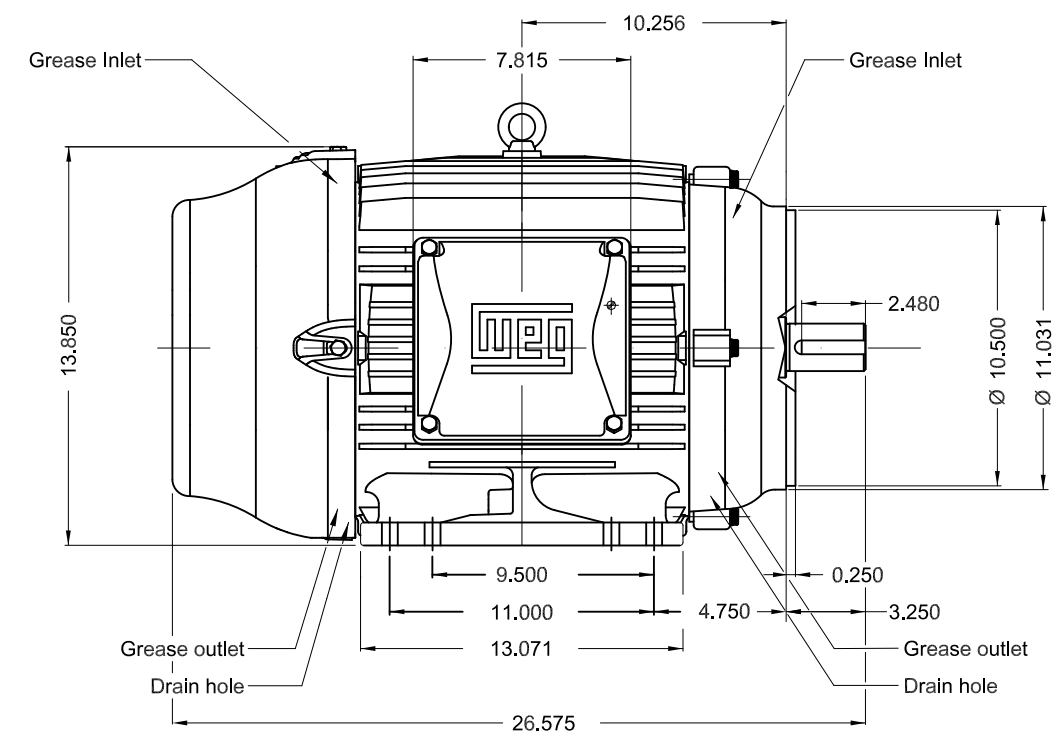
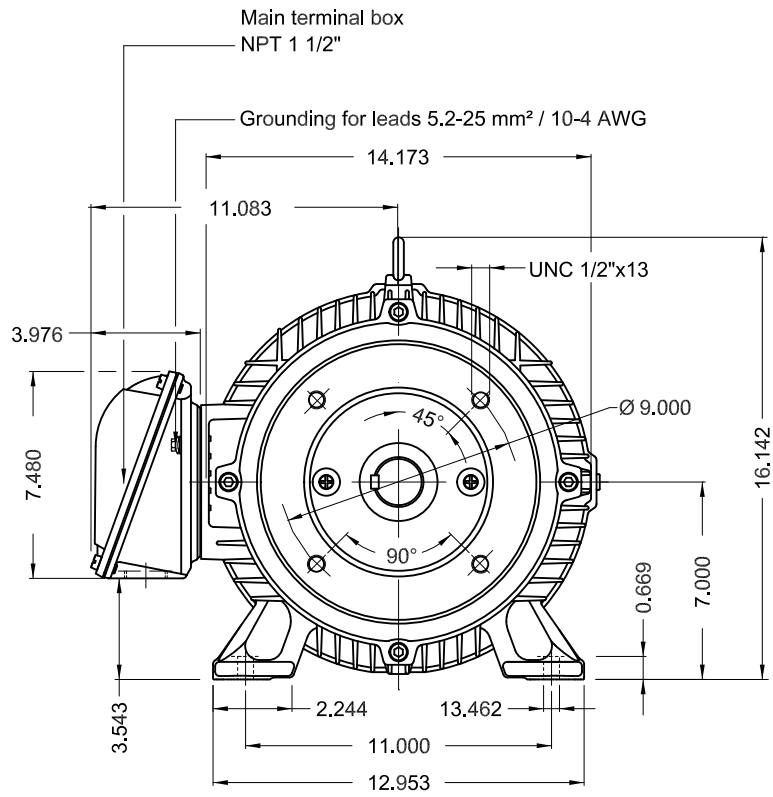

D

E

Color RAL 5009  
 Painting plan 203A  
 Mounting B34R(D)

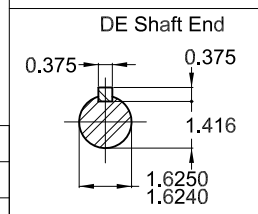

25 HP 02 Poles 60 Hz A

ECM	LOC	SUMMARY OF MODIFICATIONS	EXECUTED	CHECKED	RELEASED	DATE	VER
EXECUTED	PIRWBUSER	THREE PH. MOTOR W22 PREM. EFF.					
CHECKED		FRAME 284/6TSC IP55 TEFC					
RELEASED							
REL DT.	WMO	Jaragua do Sul	Product Engineering				

PREVIEW  
 WDD



SHEET 1 / 1

Dimensions in inches XME A3



**NEMA**  
Premium  
W22



FOR SAFE AREA  
Mod.TE1BFOXON  
CC029A



Class I, Div 2, Gr A, B, C and D - T3  
Class I, Zone 2, IIC - T3  
Class II, Div 2, Gr F and G - T4  
For use on PWM: Gr. A, B, C, D and F,  
VT 1000:1, CT 20:1, 1.00SF - T3A

MODEL 02536ET3H284TSC-W22

Inverter Duty Motor  
Severe Duty

PH3 60Hz Fr. 284/6TSC 1000m.a.s.l. IP55 TEFC 404lb

V 575

A 23.0

HP 25

kW 18.5

SF 1.25

SFA 28.8

RPM 3545

PF 0.88

AMB 40°C

INS cl. F DT80K

NEMA NOM EFF 91.7%

DUTY CONT.

DES B Code G

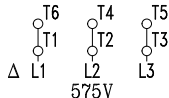

→ 6311-C3 (18g)

→ 6211-C3 (11g)



MOBIL POLYREX EM (14000h)

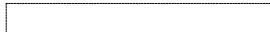

MADE IN BRAZIL  
12447105