

DATA SHEET



Three Phase Induction Motor - Squirrel Cage

Customer :																			
Product line	: NEMA Premium Efficiency Three-Phase																		
Product code :	13506429																		
Catalog # :	04036ET3H286JP-W22																		
Frame : 284/6JP Output : 40 HP (30 kW) Poles : 2 Frequency : 60 Hz Rated voltage : 575 V Rated current : 36.6 A L. R. Amperes : 289 A LRC : 7.9x(Code J) No load current : 9.71 A Rated speed : 3540 rpm Slip : 1.67 % Rated torque : 59.3 ft.lb Locked rotor torque : 220 % Breakdown torque : 300 % Insulation class : F Service factor : 1.00 Design : A	Locked rotor time : 18s (cold) 10s (hot) Temperature rise : 80 K Duty cycle : Cont.(S1) Ambient temperature : -20°C to +40°C Altitude : 1000 m.a.s.l. Protection degree : IP55 Cooling method : IC411 - TEFC Mounting : F-1 Rotation ¹ : Both (CW and CCW) Noise level ² : 72.0 dB(A) Starting method : Direct On Line Approx. weight ³ : 437 lb																		
Output	25% 50% 75% 100%																		
Efficiency (%)	0.000 91.7 92.4 92.4																		
Power Factor	0.00 0.80 0.86 0.89																		
Foundation loads																			
Max. traction	: 558 lb																		
Max. compression	: 994 lb																		
	<table border="0"> <tr> <td></td> <td style="text-align: center;"><u>Drive end</u></td> <td style="text-align: center;"><u>Non drive end</u></td> </tr> <tr> <td>Bearing type :</td> <td>6311 C3</td> <td>6211 C3</td> </tr> <tr> <td>Sealing :</td> <td>V'Ring</td> <td>V'Ring</td> </tr> <tr> <td>Lubrication interval :</td> <td>14000 h</td> <td>17000 h</td> </tr> <tr> <td>Lubricant amount :</td> <td>18 g</td> <td>11 g</td> </tr> <tr> <td>Lubricant type :</td> <td colspan="2" style="text-align: center;">Mobil Polyrex EM</td> </tr> </table>		<u>Drive end</u>	<u>Non drive end</u>	Bearing type :	6311 C3	6211 C3	Sealing :	V'Ring	V'Ring	Lubrication interval :	14000 h	17000 h	Lubricant amount :	18 g	11 g	Lubricant type :	Mobil Polyrex EM	
	<u>Drive end</u>	<u>Non drive end</u>																	
Bearing type :	6311 C3	6211 C3																	
Sealing :	V'Ring	V'Ring																	
Lubrication interval :	14000 h	17000 h																	
Lubricant amount :	18 g	11 g																	
Lubricant type :	Mobil Polyrex EM																		
Notes																			
This revision replaces and cancel the previous one, which must be eliminated. (1) Looking the motor from the shaft end. (2) Measured at 1m and with tolerance of +3dB(A). (3) Approximate weight subject to changes after manufacturing process. (4) At 100% of full load.																			
These are average values based on tests with sinusoidal power supply, subject to the tolerances stipulated in NEMA MG-1.																			
Rev.	Changes Summary	Performed	Checked	Date															
Performed by																			
Checked by			Page	Revision															
Date	13/04/2022		1 / 6																

TORQUE AND CURRENT VS SPEED CURVE

Three Phase Induction Motor - Squirrel Cage



Customer :

Product line : NEMA Premium Efficiency Three-Phase

Product code : 13506429

Catalog # : 04036ET3H286JP-W22

TORQUE AND CURRENT VS SPEED CURVE

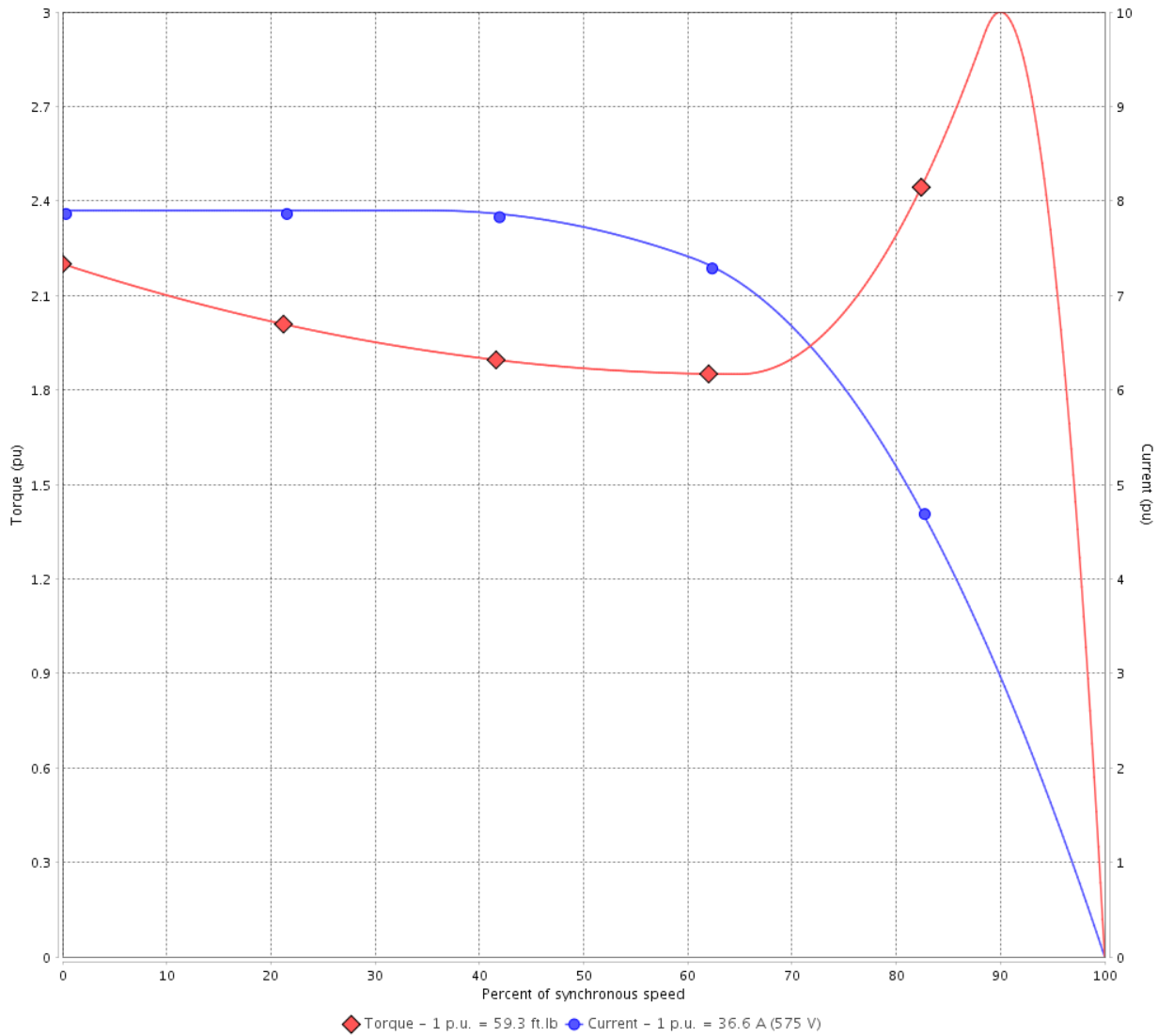

Performance : 575 V 60 Hz 2P

Rated current	: 36.6 A	Moment of inertia (J)	
LRC	: 7.9	Duty cycle	: Cont.(S1)
Rated torque	: 59.3 ft.lb	Insulation class	: F
Locked rotor torque	: 220 %	Service factor	: 1.00
Breakdown torque	: 300 %	Temperature rise	: 80 K
Rated speed	: 3540 rpm	Design	: A

Locked rotor time : 18s (cold) 10s (hot)

Rev.	Changes Summary	Performed	Checked	Date
Performed by			Page 2 / 6	Revision
Checked by				
Date	13/04/2022			

LOAD PERFORMANCE CURVE

Three Phase Induction Motor - Squirrel Cage



Customer : _____

Product line : NEMA Premium Efficiency Three-Phase

Product code : 13506429

Catalog # : 04036ET3H286JP-W22

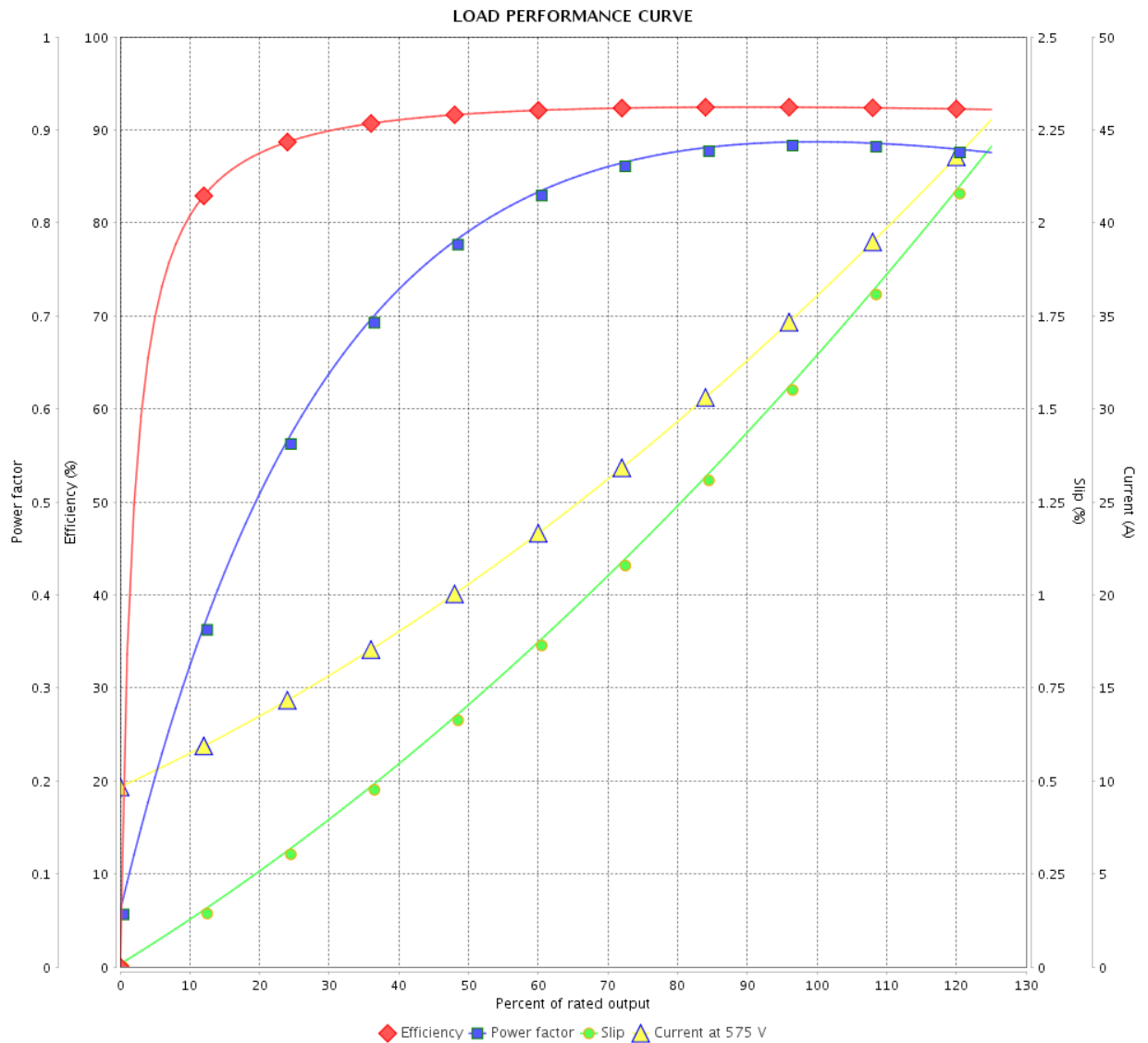

Performance : 575 V 60 Hz 2P

Rated current : 36.6 A
 LRC : 7.9
 Rated torque : 59.3 ft.lb
 Locked rotor torque : 220 %
 Breakdown torque : 300 %
 Rated speed : 3540 rpm

Moment of inertia (J)
 Duty cycle : Cont.(S1)
 Insulation class : F
 Service factor : 1.00
 Temperature rise : 80 K
 Design : A

Rev.	Changes Summary	Performed	Checked	Date
Performed by		Page		Revision
Checked by		3 / 6		
Date		13/04/2022		

THERMAL LIMIT CURVE



Three Phase Induction Motor - Squirrel Cage

Customer :

Product line : NEMA Premium Efficiency Three-Phase
Product code : 13506429
Catalog # : 04036ET3H286JP-W22

Performance : 575 V 60 Hz 2P

Rated current	: 36.6 A	Moment of inertia (J)	
LRC	: 7.9	Duty cycle	: Cont.(S1)
Rated torque	: 59.3 ft.lb	Insulation class	: F
Locked rotor torque	: 220 %	Service factor	: 1.00
Breakdown torque	: 300 %	Temperature rise	: 80 K
Rated speed	: 3540 rpm	Design	: A

Heating constant

Cooling constant

Rev.	Changes Summary	Performed	Checked	Date
Performed by				
Checked by			Page	Revision
Date	13/04/2022		4 / 6	

THERMAL LIMIT CURVE

Three Phase Induction Motor - Squirrel Cage



Customer : _____

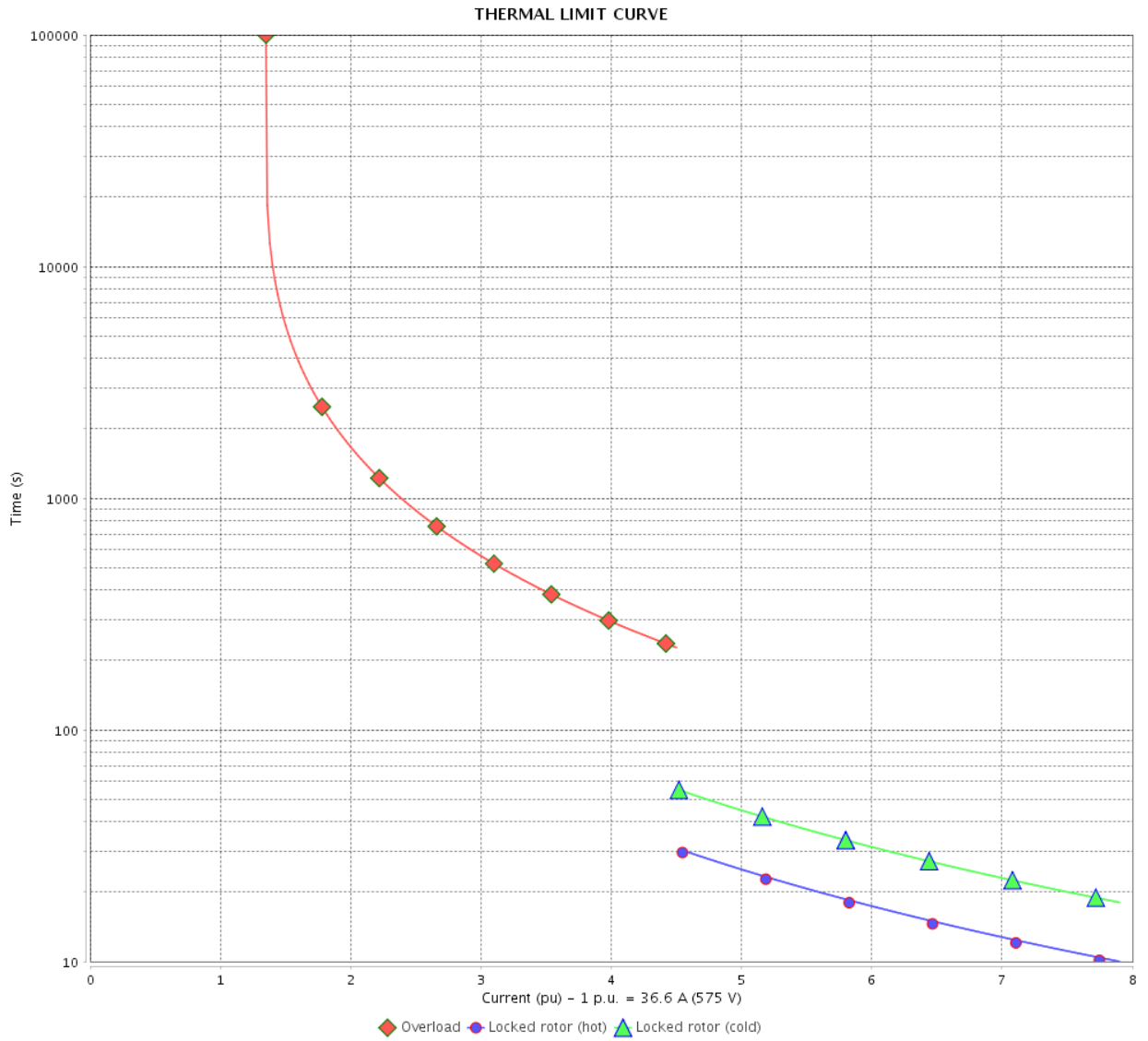

Rev.	Changes Summary	Performed	Checked	Date
Performed by		Page 5 / 6		Revision
Checked by				
Date				

VFD OPERATION CURVE

Three Phase Induction Motor - Squirrel Cage



Customer :

Product line : NEMA Premium Efficiency Three-Phase

Product code : 13506429

Catalog # : 04036ET3H286JP-W22

VFD OPERATION CURVE

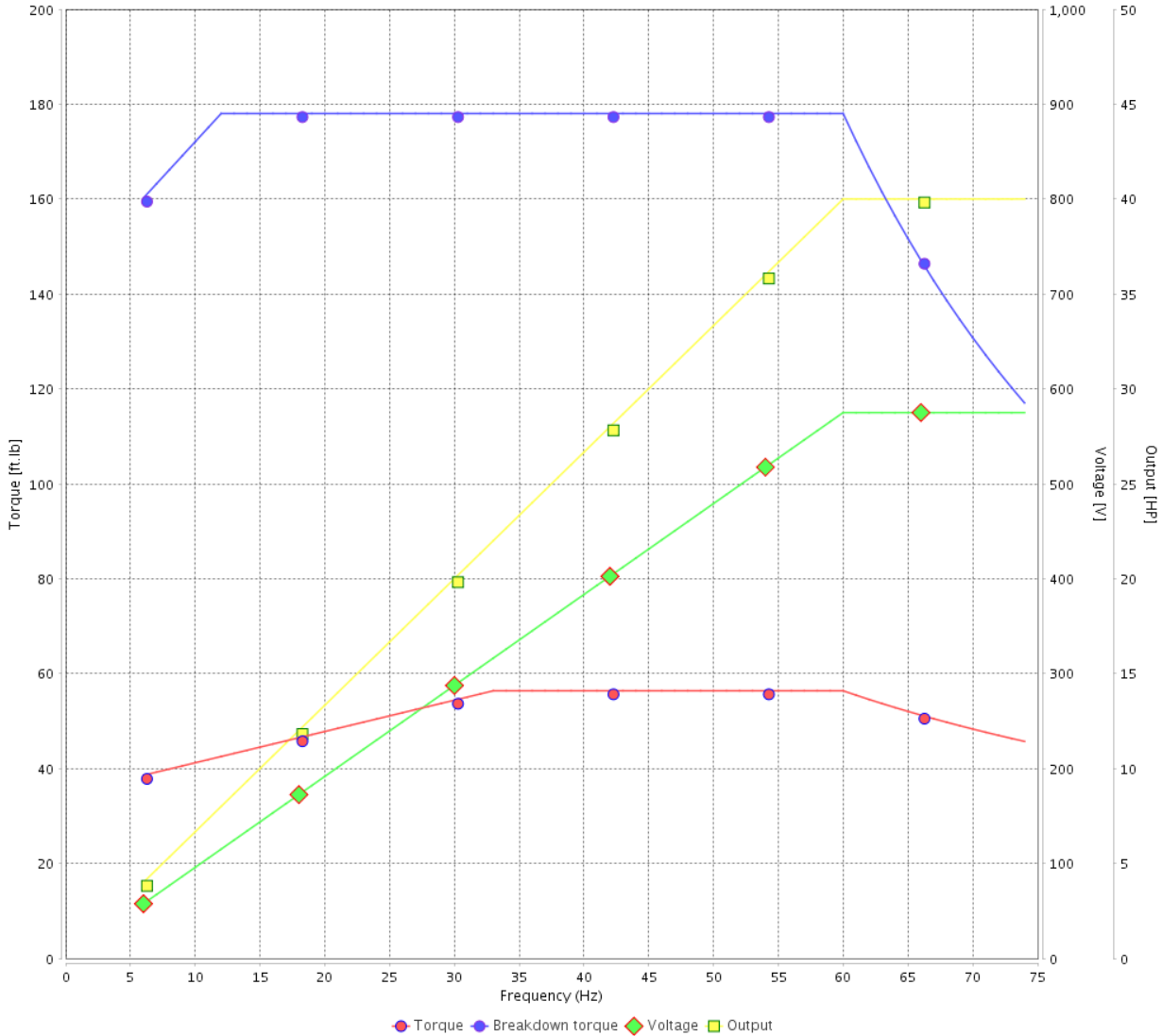

Performance : 575 V 60 Hz 2P

Rated current : 36.6 A
 LRC : 7.9
 Rated torque : 59.3 ft.lb
 Locked rotor torque : 220 %
 Breakdown torque : 300 %
 Rated speed : 3540 rpm

Moment of inertia (J)
 Duty cycle : Cont.(S1)
 Insulation class : F
 Service factor : 1.00
 Temperature rise : 80 K
 Design : A

Rev.	Changes Summary	Performed	Checked	Date
Performed by			Page 6 / 6	Revision
Checked by				
Date	13/04/2022			

1 2 3 4 5 6

A

B

C

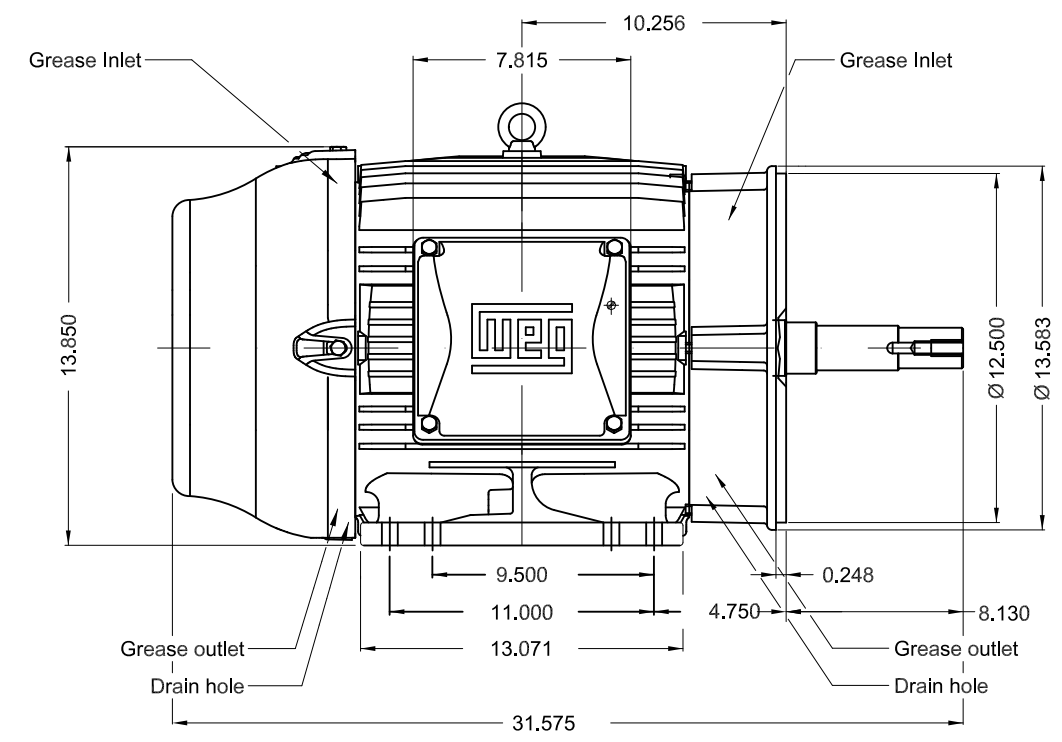
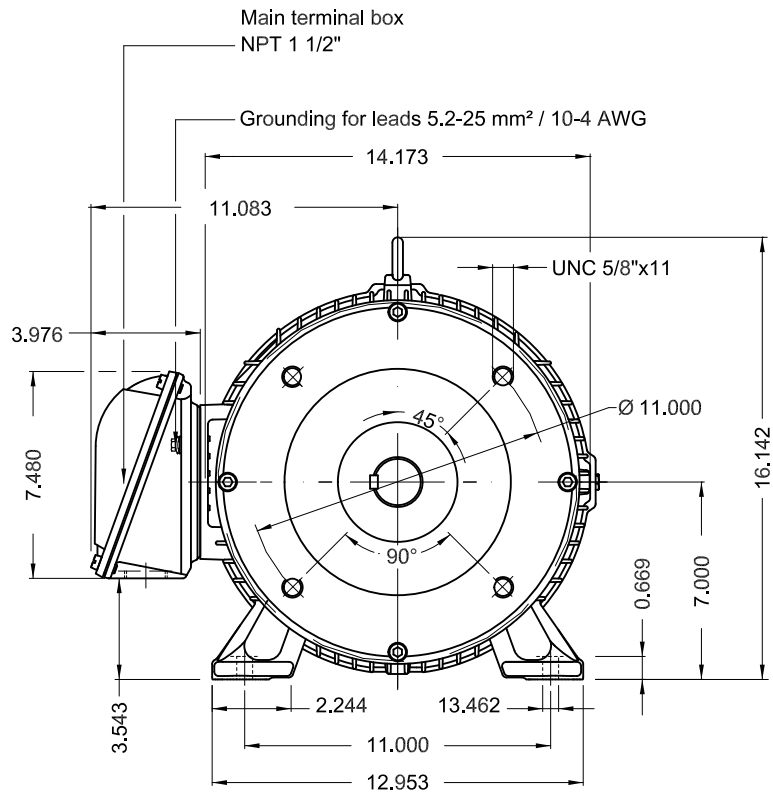

D

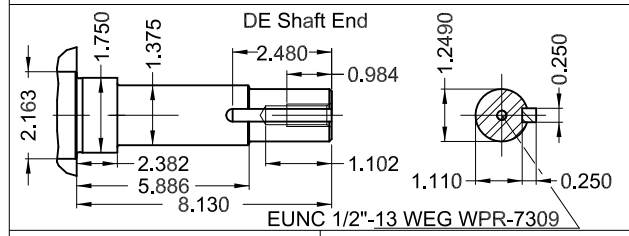

E

Design A
Color RAL 5009
Painting plan 203A
Service factor 1.0
Mounting NEMA F-1
Mounting B34R(D)

40 HP 02 Poles 60 Hz A

ECM	LOC	SUMMARY OF MODIFICATIONS			EXECUTED	CHECKED	RELEASED	DATE	VER
EXECUTED	PIRWBUSER		THREE PH. MOTOR JM/JP/JET PUMP W22 PREM. EFF.			<p>PREVIEW</p> <p>WDD</p>		SHEET	1 / 1
CHECKED			FRAME 284/6JP IP55 TEFC						
RELEASED									
REL DT.			WMO	Jaragua do Sul	Product Engineering				

Dimensions in inches

XME A3