

DATA SHEET

Three Phase Induction Motor - Squirrel Cage



Customer :					
Product line	: W40 NEMA Premium Efficiency Three-Phase	Product code :	14504114		
		Catalog # :	05018OT3E326T-W40G		
Frame	: 324/6T	Cooling method	: IC01 - ODP		
Insulation class	: F	Mounting	: F-1		
Duty cycle	: Cont.(S1)	Rotation ¹	: Both (CW and CCW)		
Ambient temperature	: -20°C to +40°C	Starting method	: Direct On Line		
Altitude	: 1000 m.a.s.l.	Approx. weight ²	: 512 lb		
Protection degree	: IP23	Moment of inertia (J)	: 7.08 sq.ft.lb		
Design	: B				
Output [HP]	50	40	40	40	
Poles	4	4	4	4	
Frequency [Hz]	60	50	50	50	
Rated voltage [V]	230/460	380	400	415	
Rated current [A]	117/58.5	58.0	56.4	55.7	
L. R. Amperes [A]	737/369	383	389	401	
LRC [A]	6.3x(Code G)	6.6x(Code G)	6.9x(Code H)	7.2x(Code J)	
No load current [A]	46.4/23.2	22.8	25.2	27.0	
Rated speed [RPM]	1775	1475	1475	1480	
Slip [%]	1.39	1.67	1.67	1.33	
Rated torque [ft.lb]	148	142	142	142	
Locked rotor torque [%]	240	220	250	270	
Breakdown torque [%]	240	240	270	300	
Service factor	1.25	1.00	1.00	1.00	
Temperature rise	80 K	80 K	80 K	80 K	
Locked rotor time	19s (cold) 11s (hot)	21s (cold) 12s (hot)	21s (cold) 12s (hot)	21s (cold) 12s (hot)	
Noise level ²	66.0 dB(A)				
Efficiency (%)	25%	94.0	92.9	92.9	
	50%	94.1	93.1	93.1	
	75%	94.5	93.5	93.5	
	100%	94.5	93.6	93.6	
Power Factor	25%	0.44	0.44	0.40	
	50%	0.70	0.70	0.66	
	75%	0.80	0.80	0.77	
	100%	0.84	0.84	0.82	
Bearing type	: <u>Drive end</u> 6312 Z C3	<u>Non drive end</u> 6211 Z C3	Foundation loads		
Sealing	: Without	Without	Max. traction		
	Bearing Seal	Bearing Seal	Max. compression		
Lubrication interval	: 20000 h	20000 h			
Lubricant amount	: 21 g	11 g			
Lubricant type	: Mobil Polyrex EM				
Notes USABLE @208V 129A SF 1.15 SFA 149A					
This revision replaces and cancel the previous one, which must be eliminated. (1) Looking the motor from the shaft end. (2) Measured at 1m and with tolerance of +3dB(A). (3) Approximate weight subject to changes after manufacturing process. (4) At 100% of full load.			These are average values based on tests with sinusoidal power supply, subject to the tolerances stipulated in NEMA MG-1.		
Rev.	Changes Summary		Performed	Checked	Date
Performed by					
Checked by				Page	Revision
Date	12/04/2022			1 / 21	

TORQUE AND CURRENT VS SPEED CURVE

Three Phase Induction Motor - Squirrel Cage



Customer :

Product line : W40 NEMA Premium Efficiency
Three-Phase

Product code : 14504114

Catalog # : 05018OT3E326T-W40G

TORQUE AND CURRENT VS SPEED CURVE

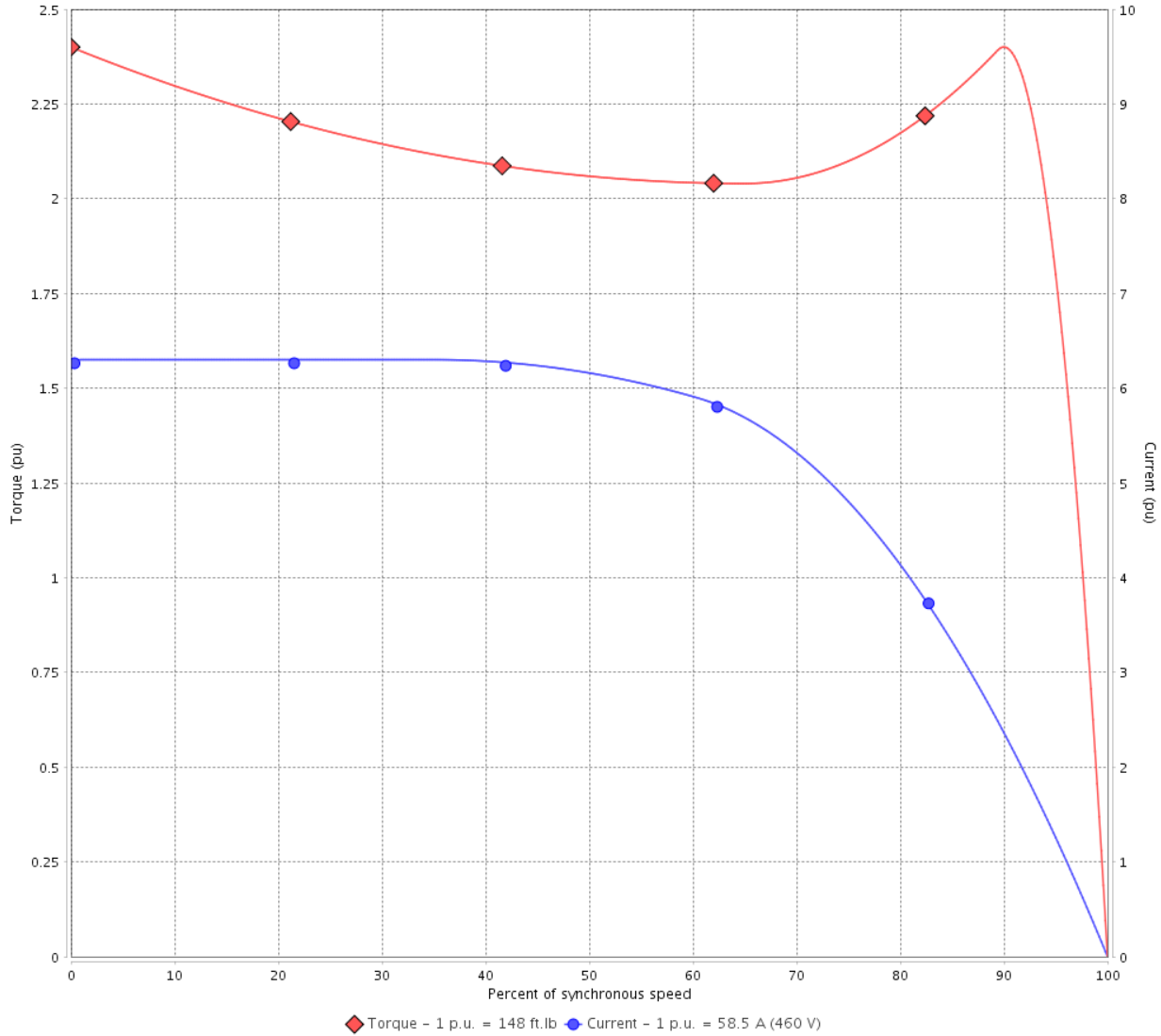

Performance : 230/460 V 60 Hz 4P

Rated current	: 117/58.5 A	Moment of inertia (J)	: 7.08 sq.ft.lb
LRC	: 6.3	Duty cycle	: Cont.(S1)
Rated torque	: 148 ft.lb	Insulation class	: F
Locked rotor torque	: 240 %	Service factor	: 1.25
Breakdown torque	: 240 %	Temperature rise	: 80 K
Rated speed	: 1775 rpm	Design	: B

Locked rotor time : 19s (cold) 11s (hot)

Rev.	Changes Summary	Performed	Checked	Date
Performed by			Page 2 / 21	Revision
Checked by				
Date	12/04/2022			

TORQUE AND CURRENT VS SPEED CURVE



Three Phase Induction Motor - Squirrel Cage

Customer :

Product line : W40 NEMA Premium Efficiency
Three-Phase

Product code : 14504114

Catalog # : 05018OT3E326T-W40G

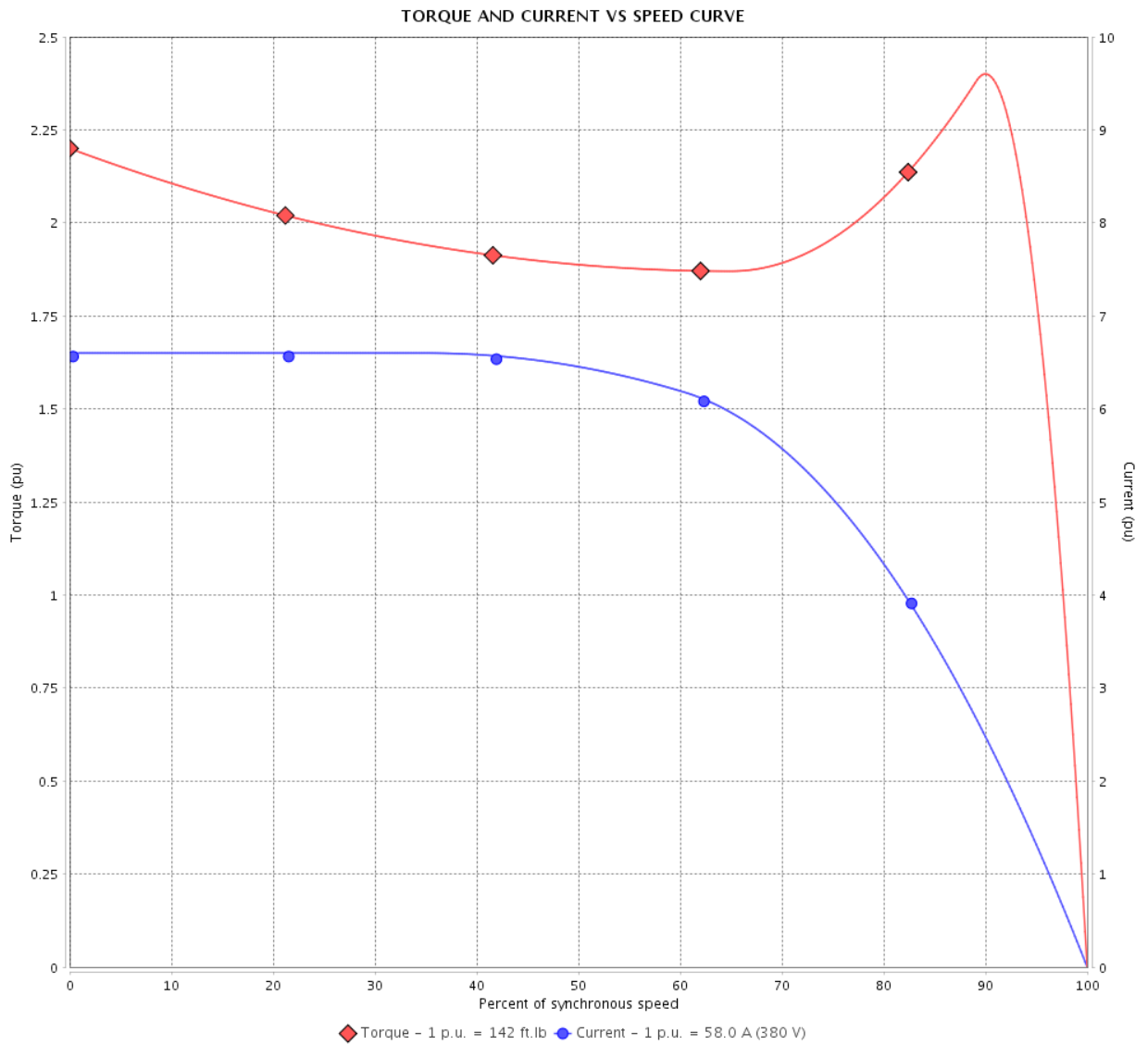

Performance : 380 V 50 Hz 4P IE3

Rated current	: 58.0 A	Moment of inertia (J)	: 7.08 sq.ft.lb
LRC	: 6.6	Duty cycle	: Cont.(S1)
Rated torque	: 142 ft.lb	Insulation class	: F
Locked rotor torque	: 220 %	Service factor	: 1.00
Breakdown torque	: 240 %	Temperature rise	: 80 K
Rated speed	: 1475 rpm	Design	: B

Locked rotor time : 21s (cold) 12s (hot)

Rev.	Changes Summary	Performed	Checked	Date
Performed by			Page 3 / 21	Revision
Checked by				
Date	12/04/2022			

TORQUE AND CURRENT VS SPEED CURVE

Three Phase Induction Motor - Squirrel Cage



Customer :

Product line : W40 NEMA Premium Efficiency
Three-Phase

Product code : 14504114

Catalog # : 05018OT3E326T-W40G

TORQUE AND CURRENT VS SPEED CURVE

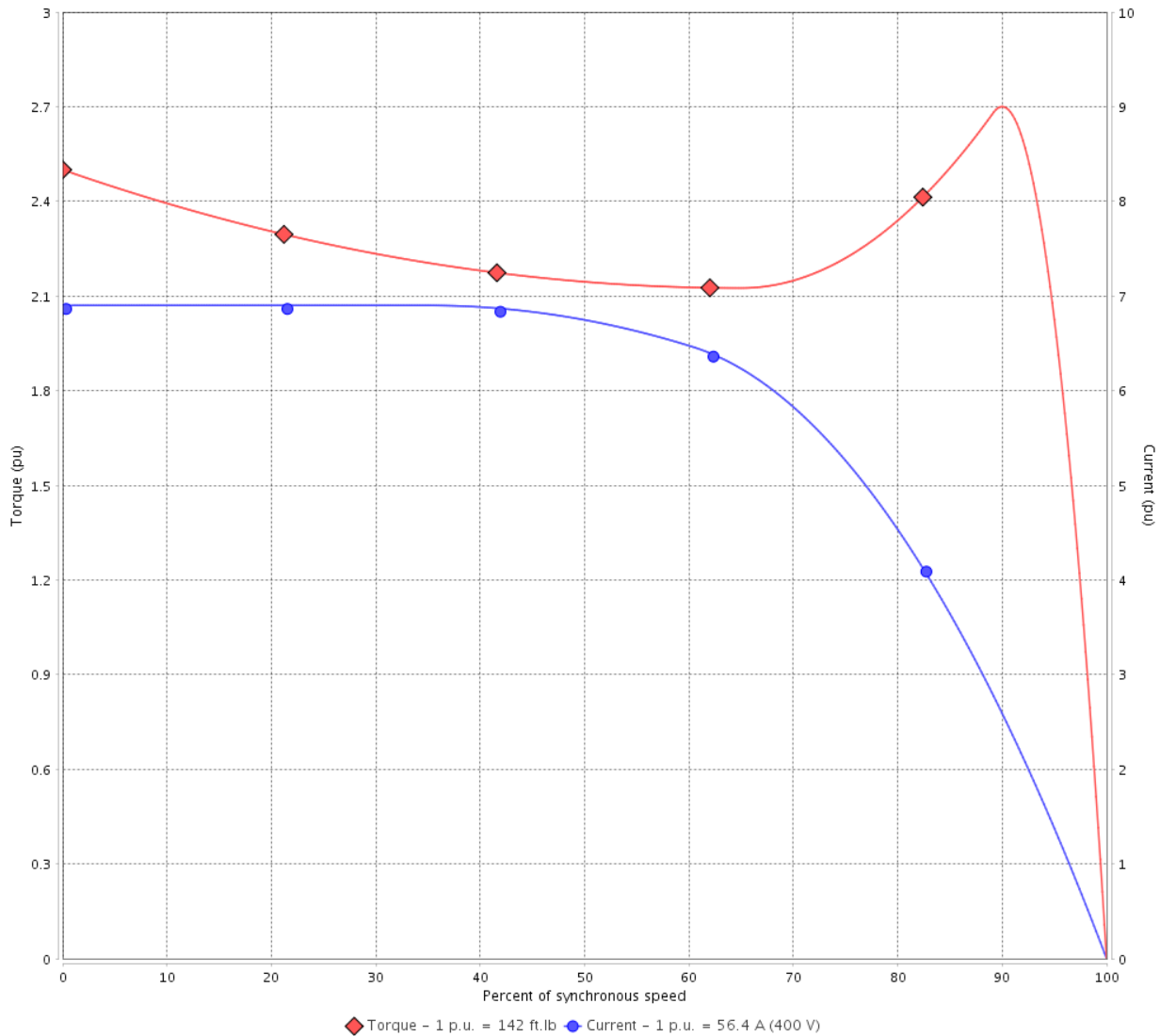

Performance : 400 V 50 Hz 4P IE3

Rated current	: 56.4 A	Moment of inertia (J)	: 7.08 sq.ft.lb
LRC	: 6.9	Duty cycle	: Cont.(S1)
Rated torque	: 142 ft.lb	Insulation class	: F
Locked rotor torque	: 250 %	Service factor	: 1.00
Breakdown torque	: 270 %	Temperature rise	: 80 K
Rated speed	: 1475 rpm	Design	: B

Locked rotor time : 21s (cold) 12s (hot)

Rev.	Changes Summary	Performed	Checked	Date
Performed by			Page 4 / 21	Revision
Checked by				
Date	12/04/2022			

TORQUE AND CURRENT VS SPEED CURVE



Three Phase Induction Motor - Squirrel Cage

Customer :

Product line : W40 NEMA Premium Efficiency
Three-Phase

Product code : 14504114

Catalog # : 05018OT3E326T-W40G

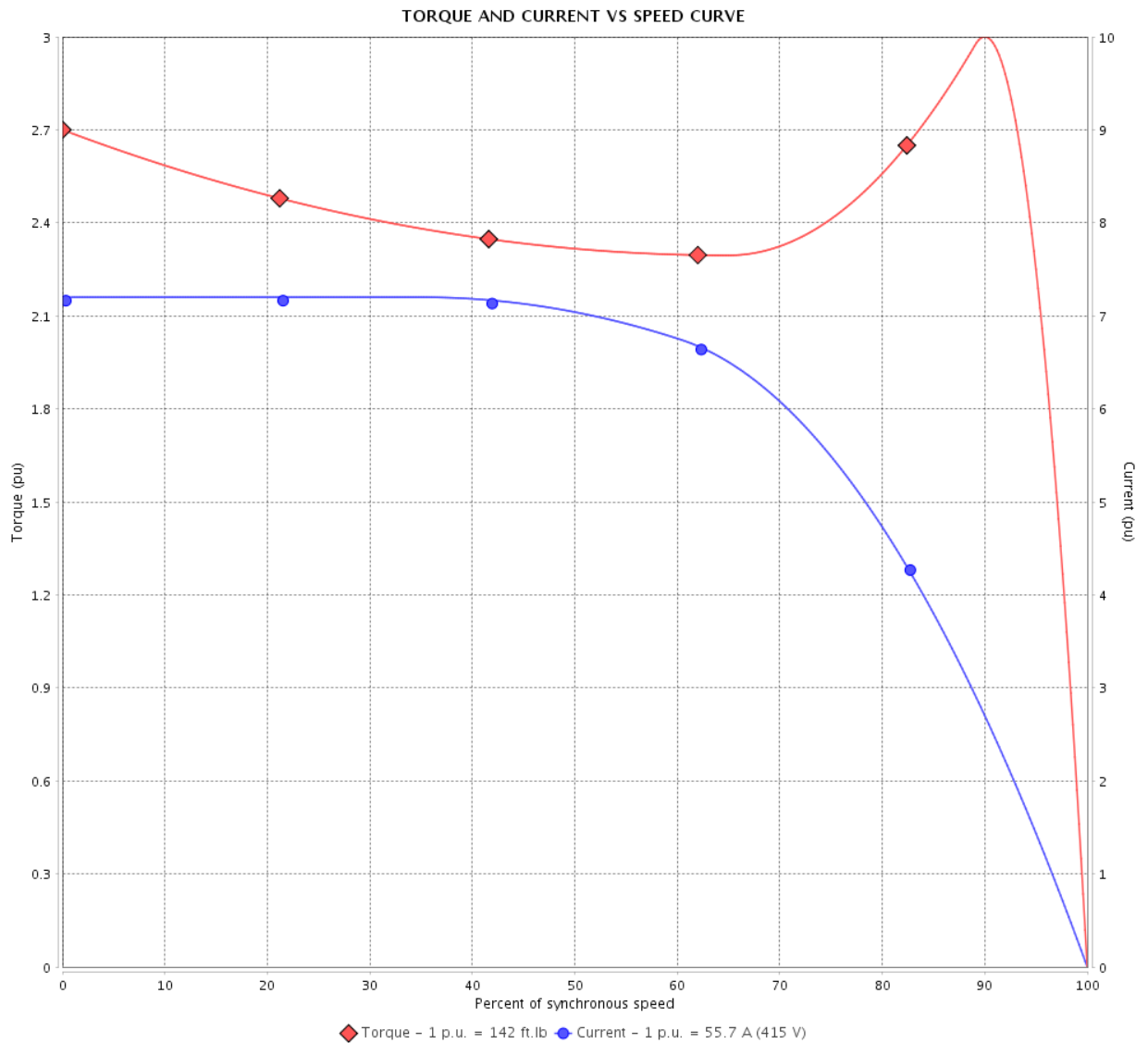

Performance : 415 V 50 Hz 4P IE3

Rated current	: 55.7 A	Moment of inertia (J)	: 7.08 sq.ft.lb
LRC	: 7.2	Duty cycle	: Cont.(S1)
Rated torque	: 142 ft.lb	Insulation class	: F
Locked rotor torque	: 270 %	Service factor	: 1.00
Breakdown torque	: 300 %	Temperature rise	: 80 K
Rated speed	: 1480 rpm	Design	: B

Locked rotor time : 21s (cold) 12s (hot)

Rev.	Changes Summary	Performed	Checked	Date
Performed by			Page	Revision
Checked by			5 / 21	
Date	12/04/2022			

LOAD PERFORMANCE CURVE

Three Phase Induction Motor - Squirrel Cage



Customer :

Product line : W40 NEMA Premium Efficiency Three-Phase

Product code : 14504114

Catalog # : 05018OT3E326T-W40G

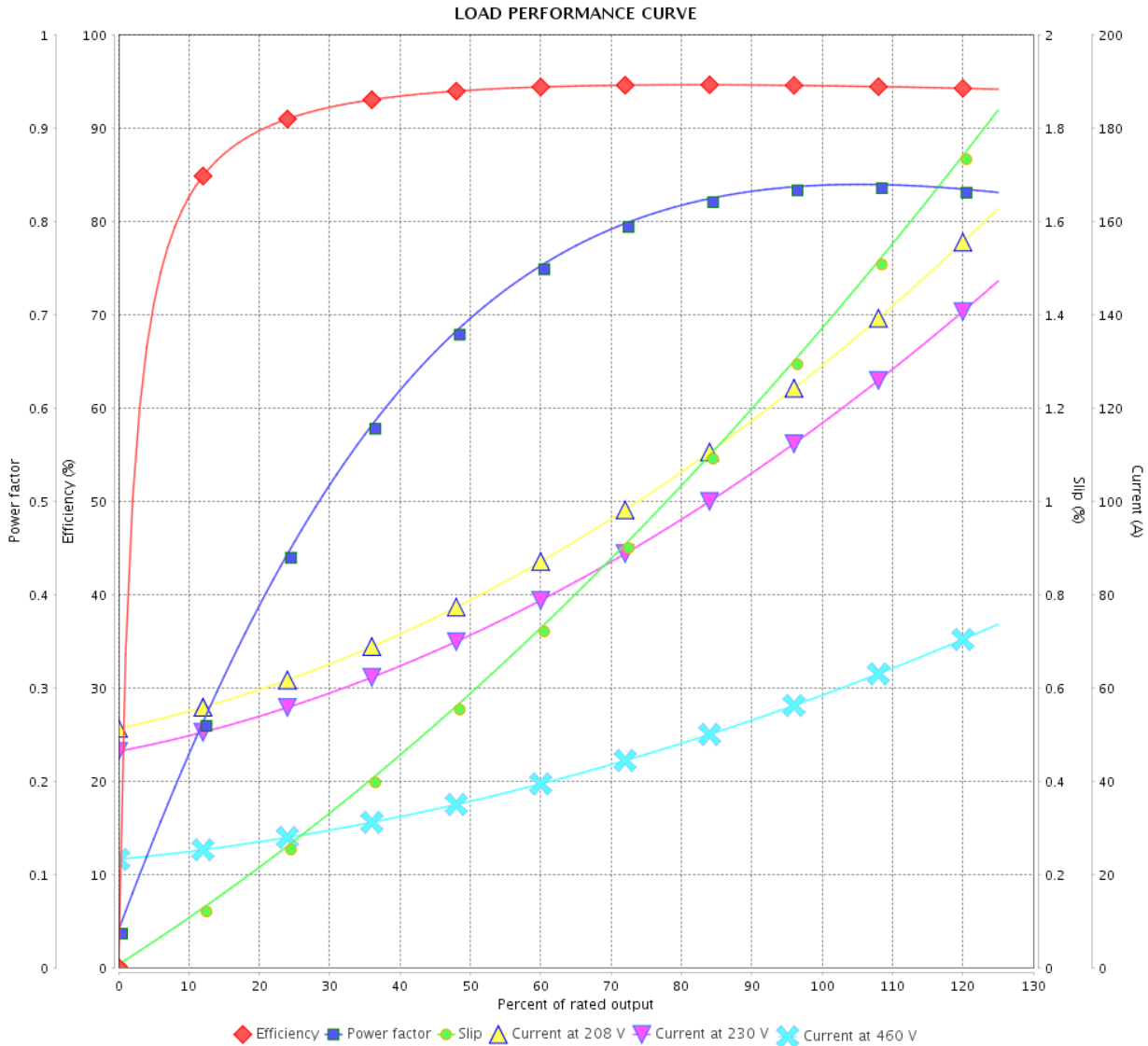

Performance : 230/460 V 60 Hz 4P

Rated current : 117/58.5 A
 LRC : 6.3
 Rated torque : 148 ft.lb
 Locked rotor torque : 240 %
 Breakdown torque : 240 %
 Rated speed : 1775 rpm

Moment of inertia (J) : 7.08 sq.ft.lb
 Duty cycle : Cont.(S1)
 Insulation class : F
 Service factor : 1.25
 Temperature rise : 80 K
 Design : B

Rev.	Changes Summary	Performed	Checked	Date
Performed by				
Checked by			Page	Revision
Date	12/04/2022		6 / 21	

LOAD PERFORMANCE CURVE

Three Phase Induction Motor - Squirrel Cage



Customer : _____

Product line : W40 NEMA Premium Efficiency
Three-Phase

Product code : 14504114

Catalog # : 05018OT3E326T-W40G

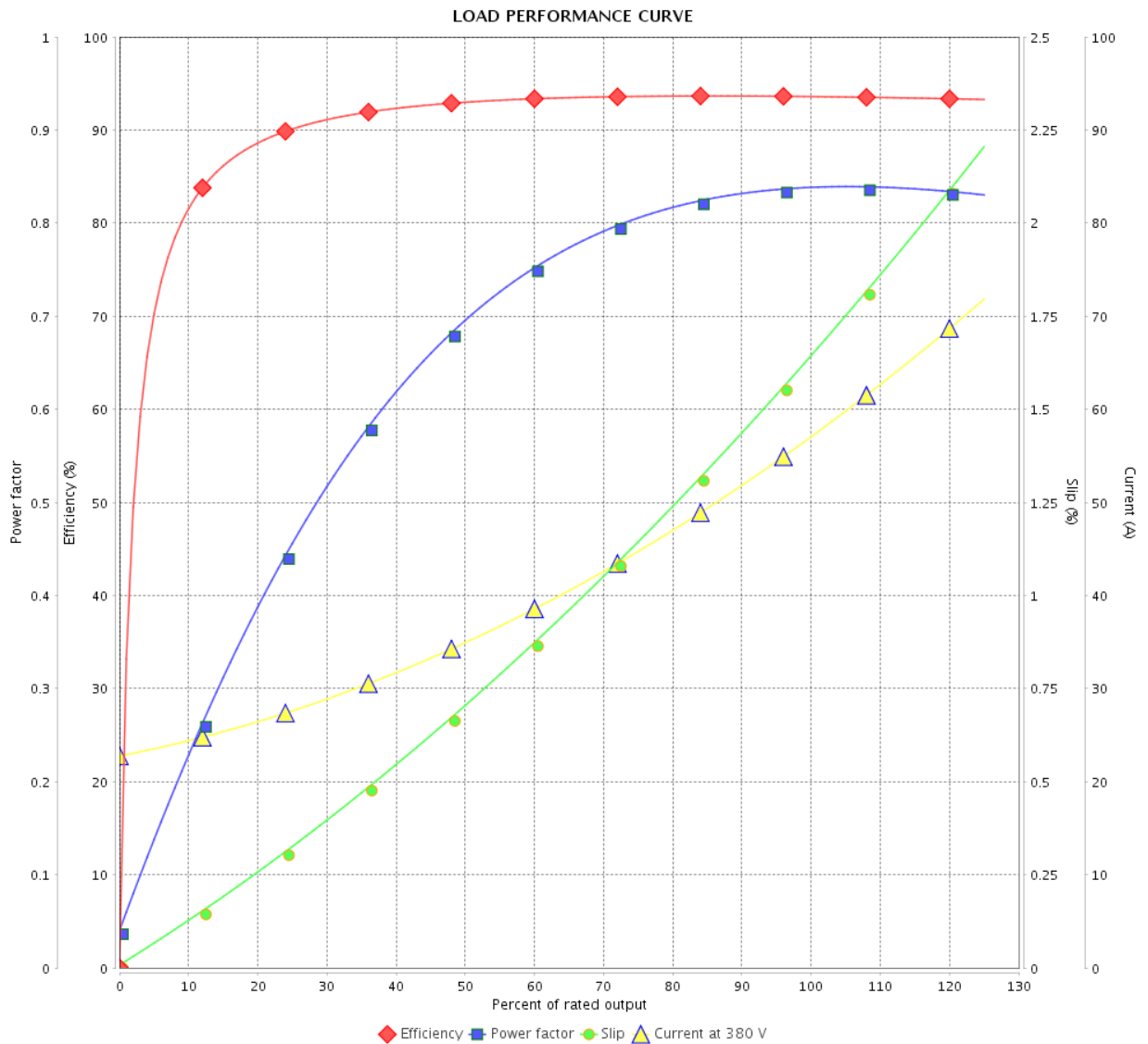

Performance : 380 V 50 Hz 4P IE3

Rated current : 58.0 A
 LRC : 6.6
 Rated torque : 142 ft.lb
 Locked rotor torque : 220 %
 Breakdown torque : 240 %
 Rated speed : 1475 rpm

Moment of inertia (J) : 7.08 sq.ft.lb
 Duty cycle : Cont.(S1)
 Insulation class : F
 Service factor : 1.00
 Temperature rise : 80 K
 Design : B

Rev.	Changes Summary	Performed	Checked	Date
Performed by			Page	Revision
Checked by			7 / 21	
Date	12/04/2022			

LOAD PERFORMANCE CURVE

Three Phase Induction Motor - Squirrel Cage



Customer :

Product line : W40 NEMA Premium Efficiency Three-Phase

Product code : 14504114

Catalog # : 05018OT3E326T-W40G

LOAD PERFORMANCE CURVE

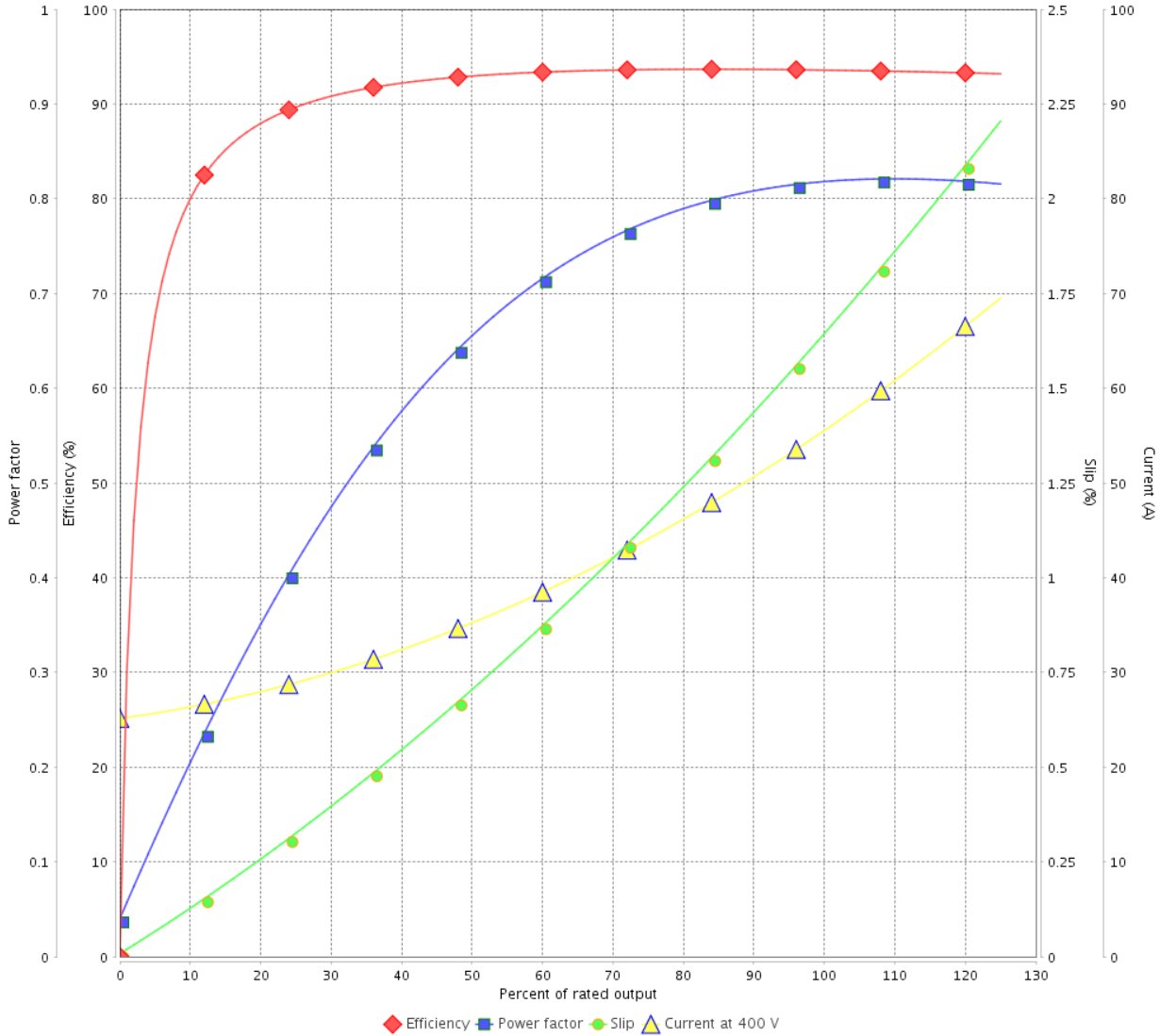

Performance : 400 V 50 Hz 4P IE3

Rated current : 56.4 A
 LRC : 6.9
 Rated torque : 142 ft.lb
 Locked rotor torque : 250 %
 Breakdown torque : 270 %
 Rated speed : 1475 rpm

Moment of inertia (J) : 7.08 sq.ft.lb
 Duty cycle : Cont.(S1)
 Insulation class : F
 Service factor : 1.00
 Temperature rise : 80 K
 Design : B

Rev.	Changes Summary	Performed	Checked	Date
Performed by			Page 8 / 21	Revision
Checked by				
Date	12/04/2022			

LOAD PERFORMANCE CURVE

Three Phase Induction Motor - Squirrel Cage



Customer :

Product line : W40 NEMA Premium Efficiency
Three-Phase

Product code : 14504114

Catalog # : 05018OT3E326T-W40G

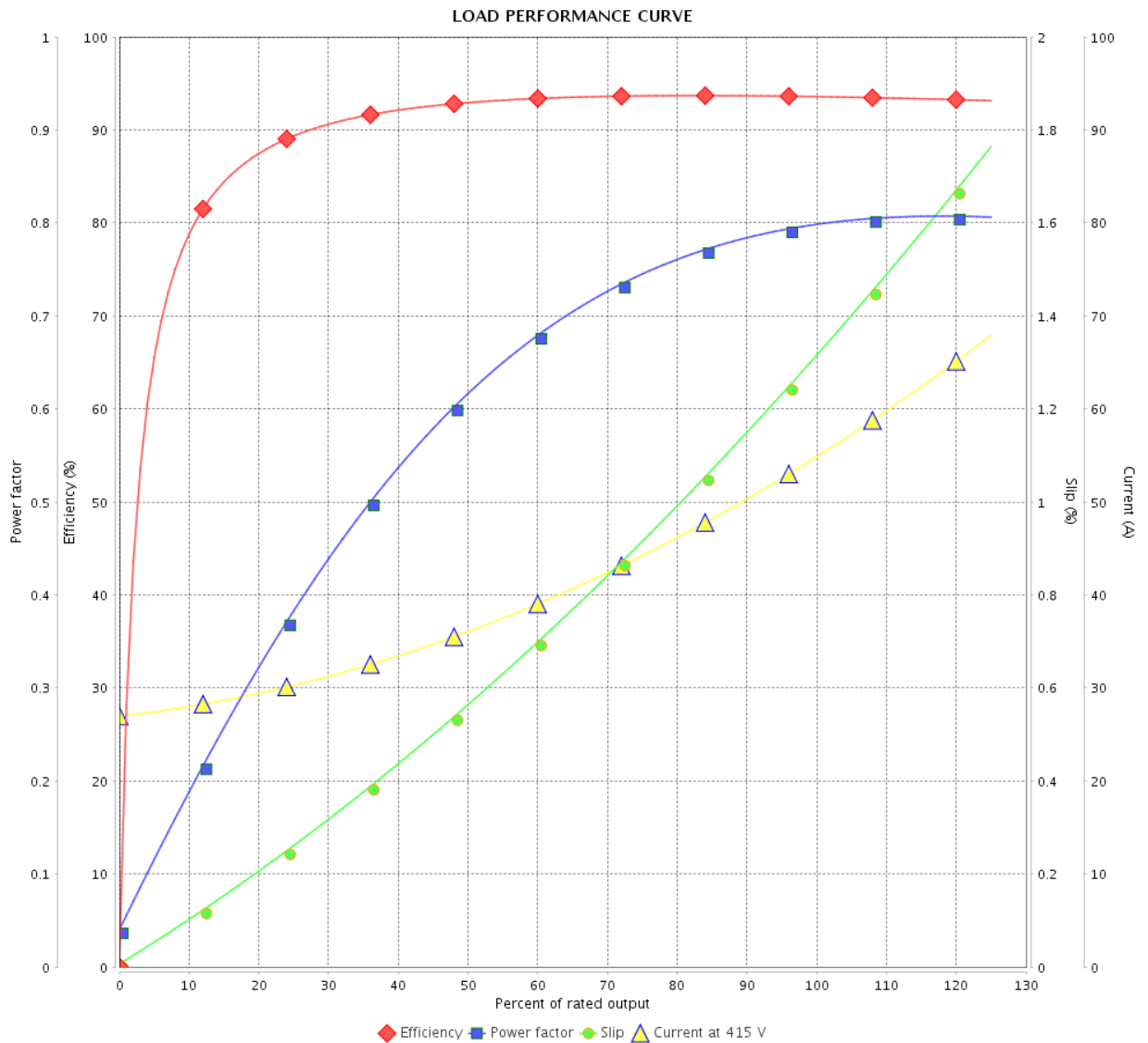

Performance : 415 V 50 Hz 4P IE3

Rated current : 55.7 A
LRC : 7.2
Rated torque : 142 ft.lb
Locked rotor torque : 270 %
Breakdown torque : 300 %
Rated speed : 1480 rpm

Moment of inertia (J) : 7.08 sq.ft.lb
Duty cycle : Cont.(S1)
Insulation class : F
Service factor : 1.00
Temperature rise : 80 K
Design : B

Rev.	Changes Summary	Performed	Checked	Date
Performed by			Page	Revision
Checked by			9 / 21	
Date	12/04/2022			

THERMAL LIMIT CURVE



Three Phase Induction Motor - Squirrel Cage

Customer :

Product line : W40 NEMA Premium Efficiency
Three-Phase

Product code : 14504114

Catalog # : 05018OT3E326T-W40G

Performance : 230/460 V 60 Hz 4P

Rated current : 117/58.5 A
LRC : 6.3
Rated torque : 148 ft.lb
Locked rotor torque : 240 %
Breakdown torque : 240 %
Rated speed : 1775 rpm

Moment of inertia (J) : 7.08 sq.ft.lb
Duty cycle : Cont.(S1)
Insulation class : F
Service factor : 1.25
Temperature rise : 80 K
Design : B

Heating constant

Cooling constant

Rev.	Changes Summary	Performed	Checked	Date
Performed by				
Checked by			Page	Revision
Date	12/04/2022		10 / 21	

THERMAL LIMIT CURVE

Three Phase Induction Motor - Squirrel Cage



Customer : _____

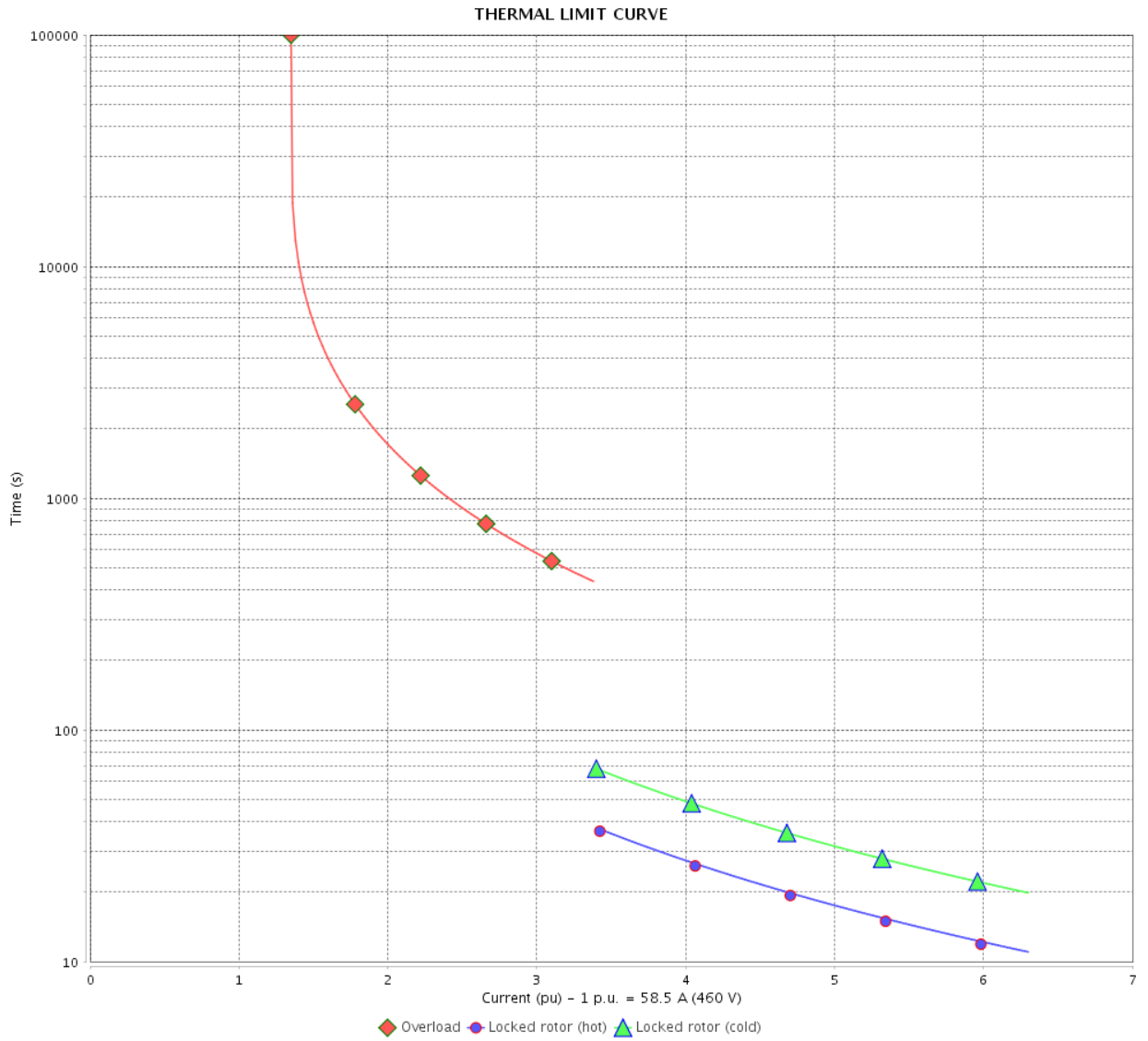

Rev.	Changes Summary	Performed	Checked	Date
Performed by		Page		Revision
Checked by		11 / 21		
Date		12/04/2022		

THERMAL LIMIT CURVE



Three Phase Induction Motor - Squirrel Cage

Customer :

Product line : W40 NEMA Premium Efficiency Three-Phase
Product code : 14504114
Catalog # : 05018OT3E326T-W40G

Performance : 380 V 50 Hz 4P IE3

Rated current	: 58.0 A	Moment of inertia (J)	: 7.08 sq.ft.lb
LRC	: 6.6	Duty cycle	: Cont.(S1)
Rated torque	: 142 ft.lb	Insulation class	: F
Locked rotor torque	: 220 %	Service factor	: 1.00
Breakdown torque	: 240 %	Temperature rise	: 80 K
Rated speed	: 1475 rpm	Design	: B

Heating constant

Cooling constant

Rev.	Changes Summary	Performed	Checked	Date
Performed by				
Checked by			Page	Revision
Date	12/04/2022		12 / 21	

THERMAL LIMIT CURVE

Three Phase Induction Motor - Squirrel Cage



Customer : _____

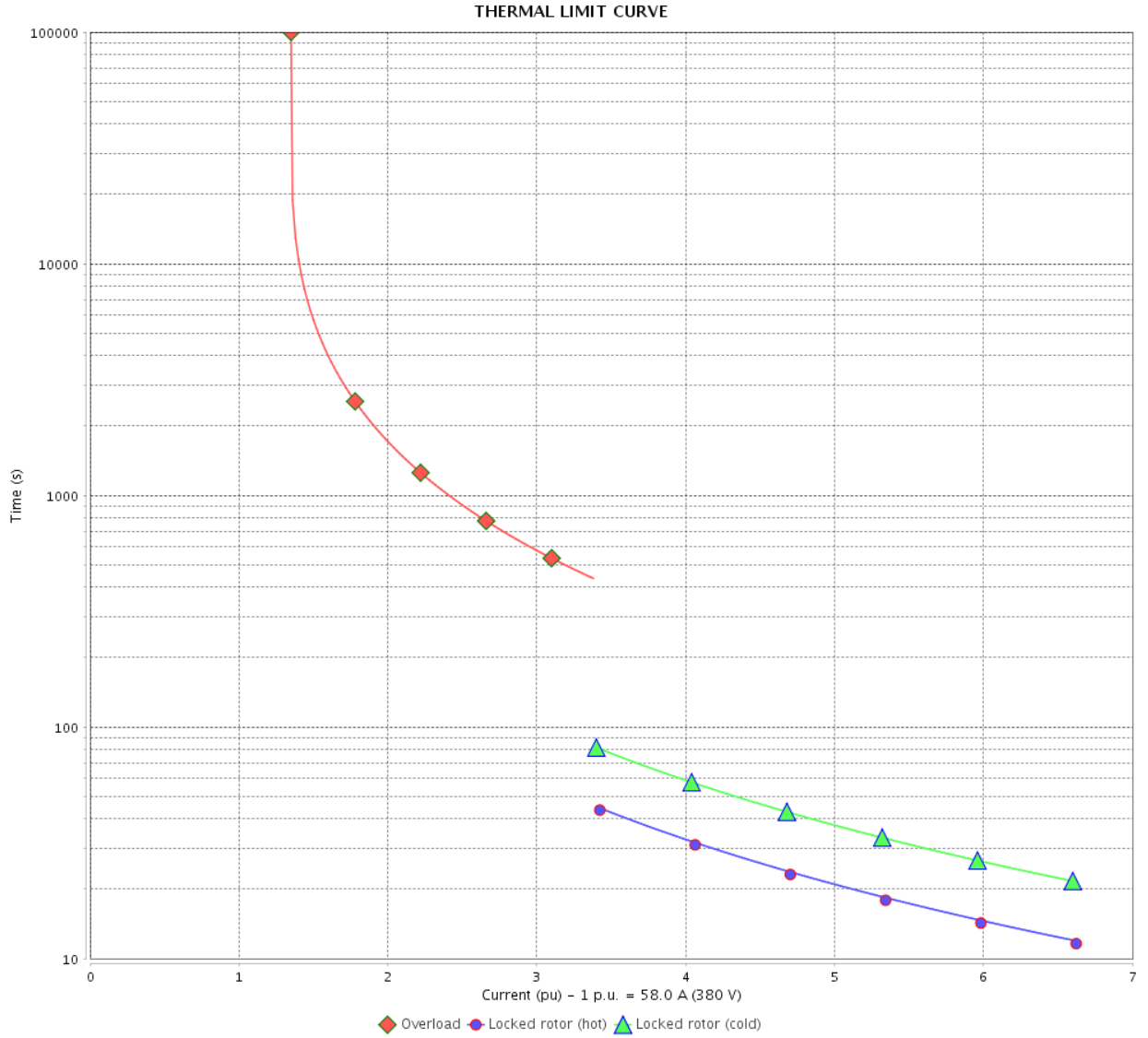

Rev.	Changes Summary	Performed	Checked	Date
Performed by		Page		Revision
Checked by		13 / 21		
Date		12/04/2022		

THERMAL LIMIT CURVE



Three Phase Induction Motor - Squirrel Cage

Customer :

Product line : W40 NEMA Premium Efficiency
Three-Phase

Product code : 14504114

Catalog # : 05018OT3E326T-W40G

Performance : 400 V 50 Hz 4P IE3

Rated current	: 56.4 A	Moment of inertia (J)	: 7.08 sq.ft.lb
LRC	: 6.9	Duty cycle	: Cont.(S1)
Rated torque	: 142 ft.lb	Insulation class	: F
Locked rotor torque	: 250 %	Service factor	: 1.00
Breakdown torque	: 270 %	Temperature rise	: 80 K
Rated speed	: 1475 rpm	Design	: B

Heating constant

Cooling constant

Rev.	Changes Summary	Performed	Checked	Date
Performed by				
Checked by			Page	Revision
Date	12/04/2022		14 / 21	

THERMAL LIMIT CURVE

Three Phase Induction Motor - Squirrel Cage



Customer : _____

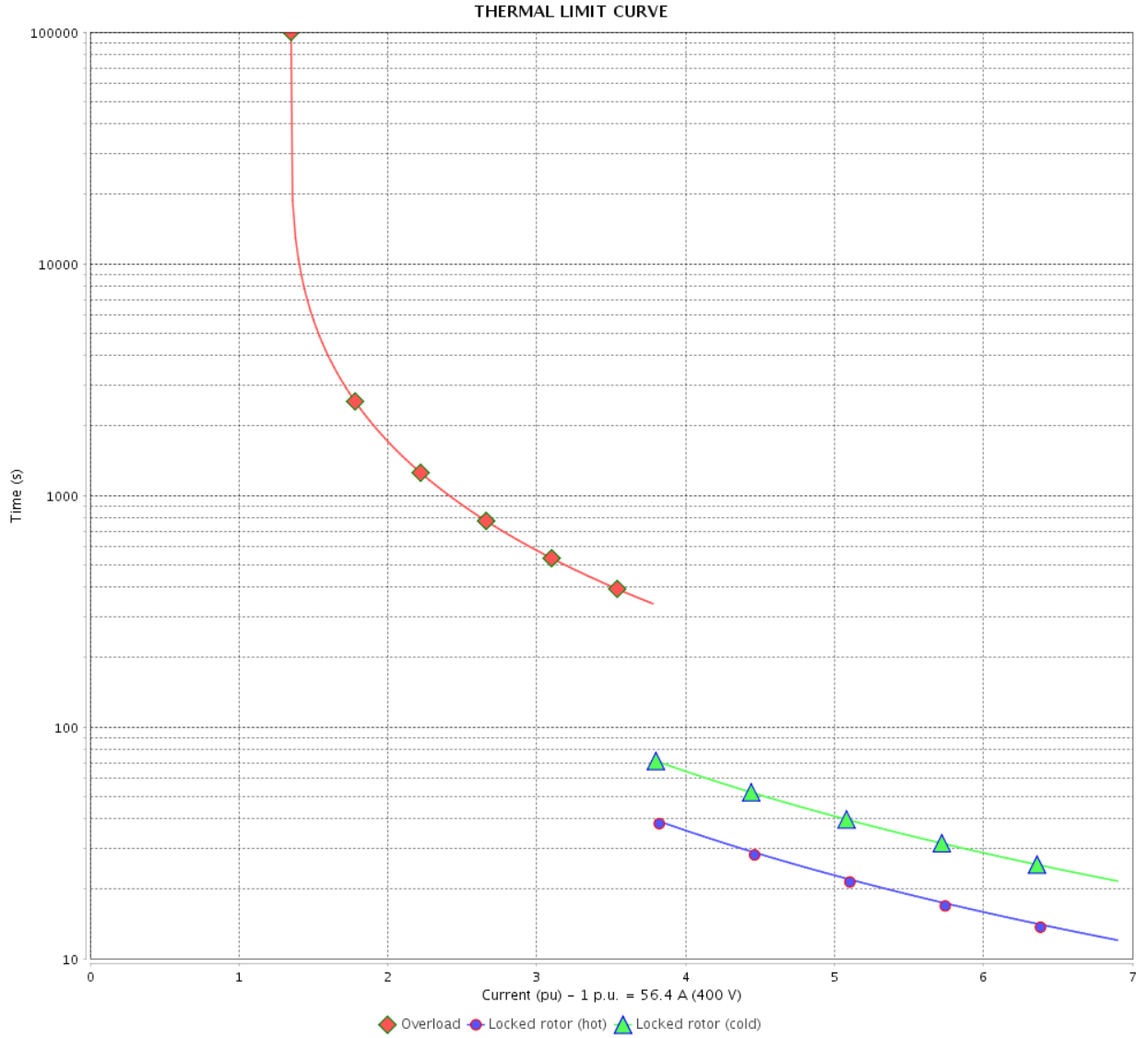

Rev.	Changes Summary	Performed	Checked	Date
Performed by		Page		Revision
Checked by		15 / 21		
Date		12/04/2022		

THERMAL LIMIT CURVE



Three Phase Induction Motor - Squirrel Cage

Customer :

Product line : W40 NEMA Premium Efficiency
Three-Phase

Product code : 14504114

Catalog # : 05018OT3E326T-W40G

Performance : 415 V 50 Hz 4P IE3

Rated current	: 55.7 A	Moment of inertia (J)	: 7.08 sq.ft.lb
LRC	: 7.2	Duty cycle	: Cont.(S1)
Rated torque	: 142 ft.lb	Insulation class	: F
Locked rotor torque	: 270 %	Service factor	: 1.00
Breakdown torque	: 300 %	Temperature rise	: 80 K
Rated speed	: 1480 rpm	Design	: B

Heating constant

Cooling constant

Rev.	Changes Summary	Performed	Checked	Date
Performed by				
Checked by			Page	Revision
Date	12/04/2022		16 / 21	

THERMAL LIMIT CURVE

Three Phase Induction Motor - Squirrel Cage



Customer : _____

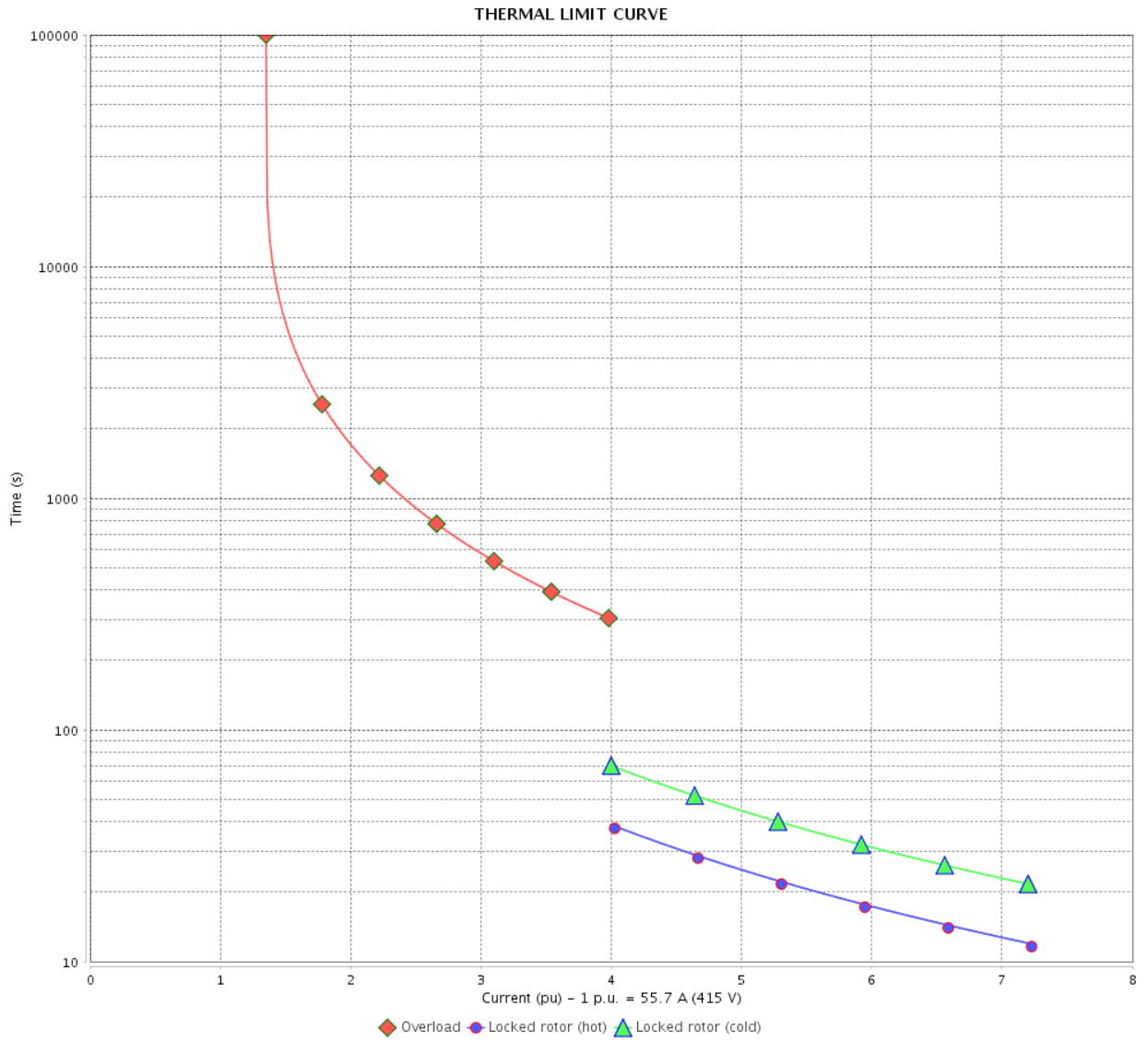

Rev.	Changes Summary	Performed	Checked	Date
Performed by		Page		Revision
Checked by		17 / 21		
Date		12/04/2022		

VFD OPERATION CURVE

Three Phase Induction Motor - Squirrel Cage



Customer :

Product line : W40 NEMA Premium Efficiency
Three-Phase

Product code : 14504114

Catalog # : 05018OT3E326T-W40G

VFD OPERATION CURVE

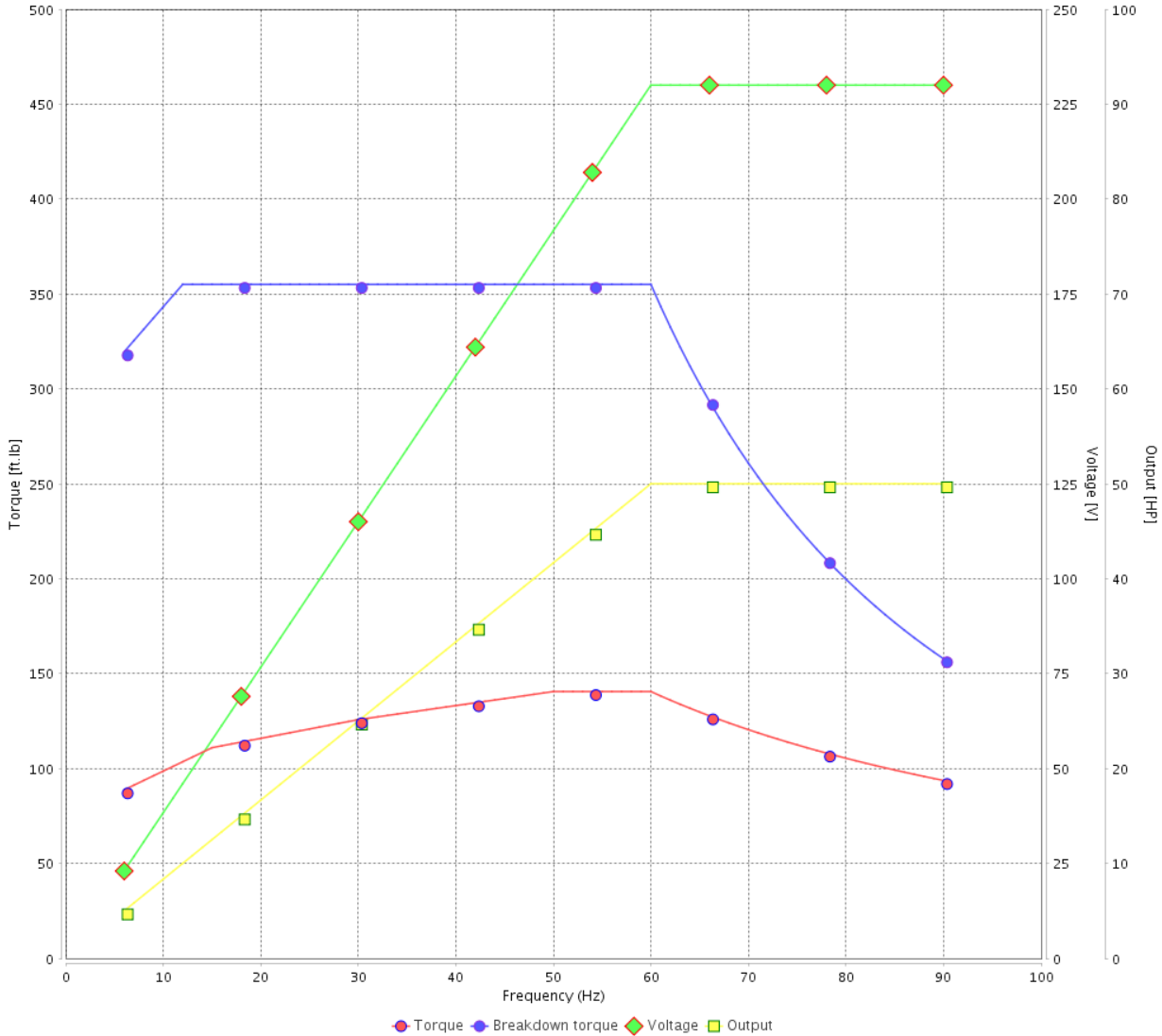

Performance : 230/460 V 60 Hz 4P

Rated current : 117/58.5 A
LRC : 6.3
Rated torque : 148 ft.lb
Locked rotor torque : 240 %
Breakdown torque : 240 %
Rated speed : 1775 rpm

Moment of inertia (J) : 7.08 sq.ft.lb
Duty cycle : Cont.(S1)
Insulation class : F
Service factor : 1.25
Temperature rise : 80 K
Design : B

Rev.	Changes Summary	Performed	Checked	Date
Performed by			Page 18 / 21	Revision
Checked by				
Date	12/04/2022			

VFD OPERATION CURVE

Three Phase Induction Motor - Squirrel Cage



Customer :

Product line : W40 NEMA Premium Efficiency Three-Phase

Product code : 14504114

Catalog # : 05018OT3E326T-W40G

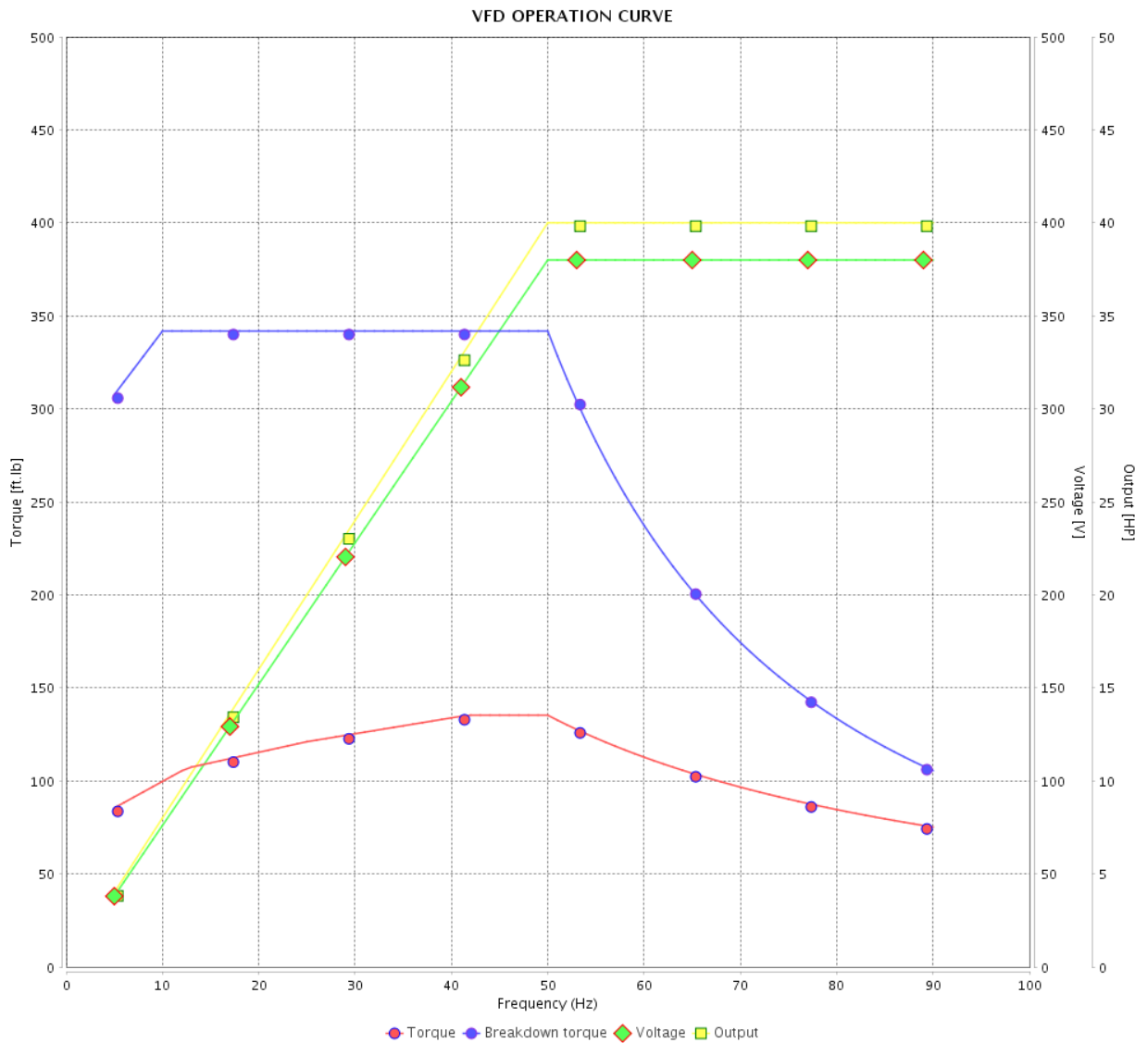

Performance : 380 V 50 Hz 4P IE3

Rated current : 58.0 A
 LRC : 6.6
 Rated torque : 142 ft.lb
 Locked rotor torque : 220 %
 Breakdown torque : 240 %
 Rated speed : 1475 rpm

Moment of inertia (J) : 7.08 sq.ft.lb
 Duty cycle : Cont.(S1)
 Insulation class : F
 Service factor : 1.00
 Temperature rise : 80 K
 Design : B

Rev.	Changes Summary	Performed	Checked	Date
Performed by			Page 19 / 21	Revision
Checked by				
Date	12/04/2022			

VFD OPERATION CURVE

Three Phase Induction Motor - Squirrel Cage



Customer :

Product line : W40 NEMA Premium Efficiency Three-Phase

Product code : 14504114

Catalog # : 05018OT3E326T-W40G

VFD OPERATION CURVE

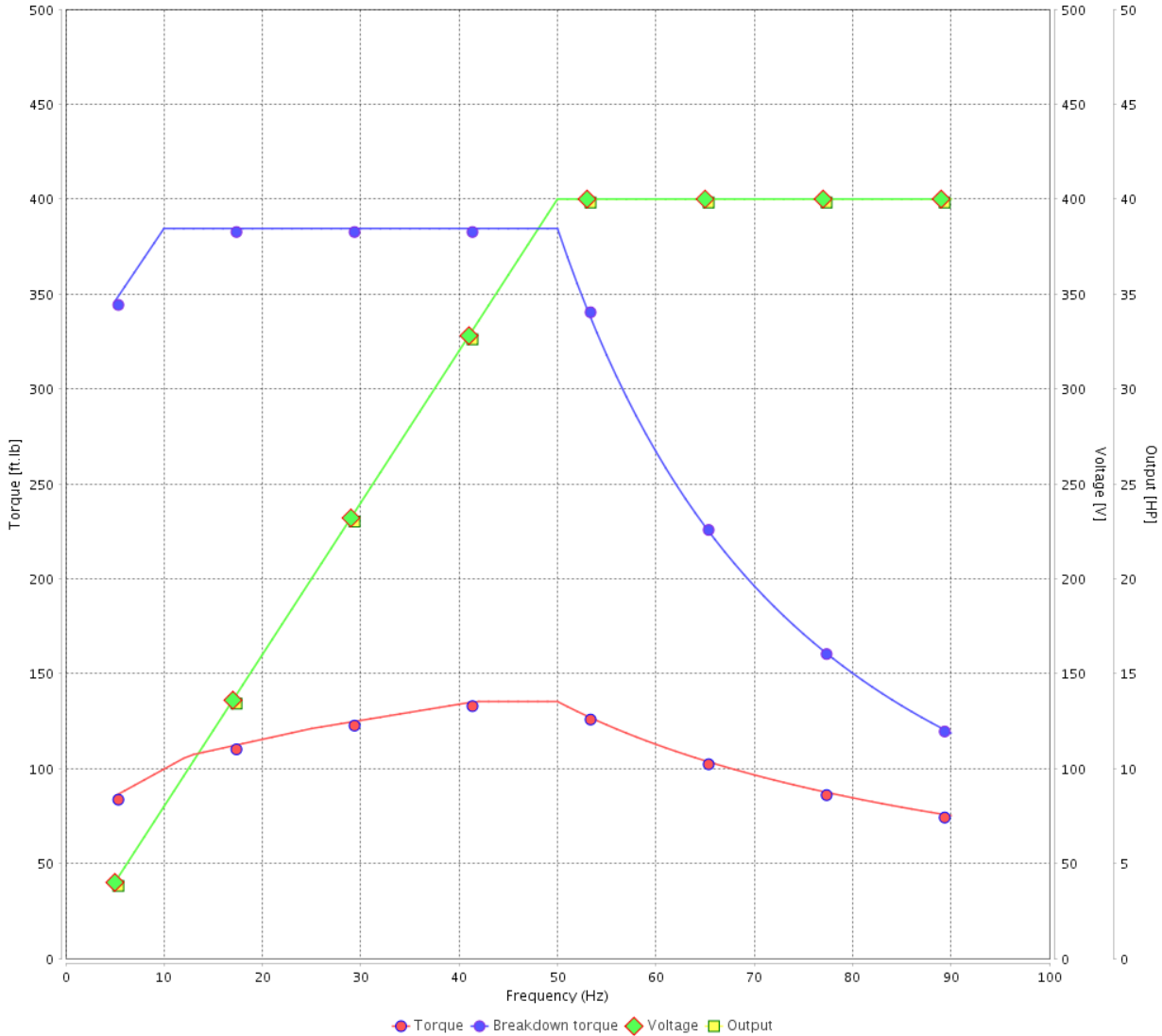

Performance : 400 V 50 Hz 4P IE3

Rated current	: 56.4 A	Moment of inertia (J)	: 7.08 sq.ft.lb
LRC	: 6.9	Duty cycle	: Cont.(S1)
Rated torque	: 142 ft.lb	Insulation class	: F
Locked rotor torque	: 250 %	Service factor	: 1.00
Breakdown torque	: 270 %	Temperature rise	: 80 K
Rated speed	: 1475 rpm	Design	: B

Rev.	Changes Summary	Performed	Checked	Date
Performed by			Page 20 / 21	Revision
Checked by				
Date	12/04/2022			

VFD OPERATION CURVE

Three Phase Induction Motor - Squirrel Cage



Customer :

Product line : W40 NEMA Premium Efficiency
Three-Phase

Product code : 14504114

Catalog # : 05018OT3E326T-W40G

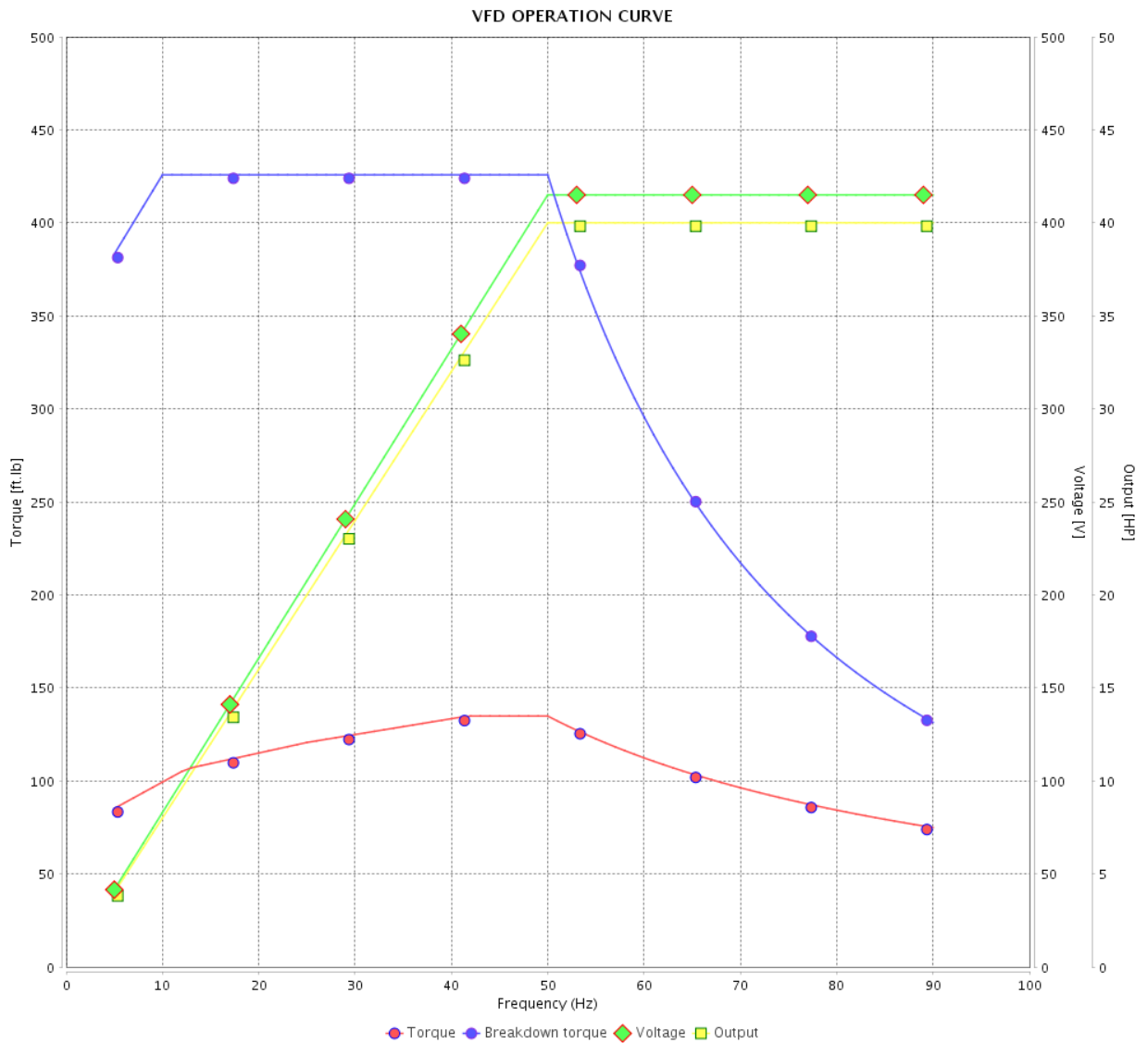

Performance : 415 V 50 Hz 4P IE3

Rated current : 55.7 A
LRC : 7.2
Rated torque : 142 ft.lb
Locked rotor torque : 270 %
Breakdown torque : 300 %
Rated speed : 1480 rpm

Moment of inertia (J) : 7.08 sq.ft.lb
Duty cycle : Cont.(S1)
Insulation class : F
Service factor : 1.00
Temperature rise : 80 K
Design : B

Rev.	Changes Summary	Performed	Checked	Date
Performed by				Page 21 / 21
Checked by				
Date	12/04/2022			
				Revision

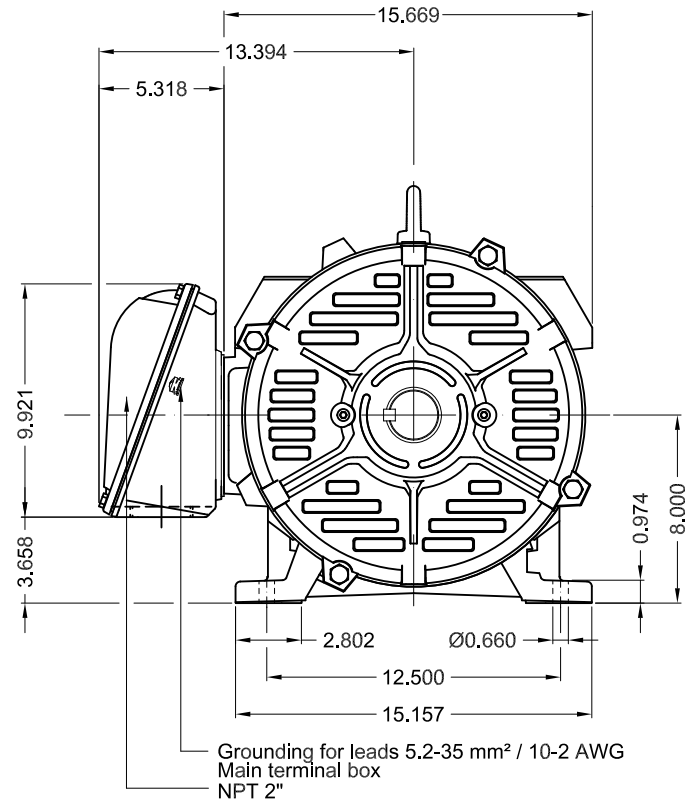

Grounding for leads 5.2-35 mm² / 10-2 AWG
Main terminal box
NPT 2"

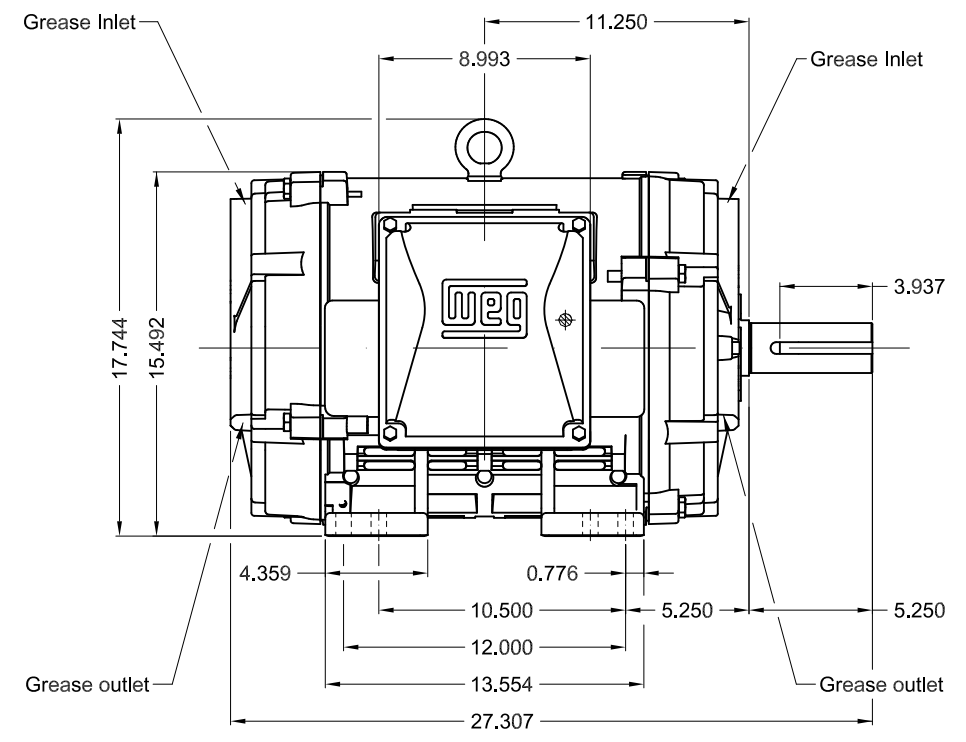

50 HP 04 Poles 60 Hz A

1:8

- Internal AEGIS ground ring on the DE
- Color RAL 5009
- Painting plan 203A
- Mounting NEMA F-1
- Mounting B3R(D)

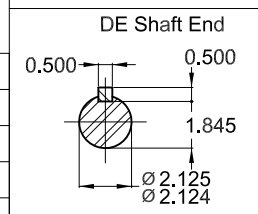

ECM	LOC	SUMMARY OF MODIFICATIONS	EXECUTED	CHECKED	RELEASED	DATE	VER
EXECUTED	PIRWBUSER	THREE PH. MOTOR W40 PREM. EFF. FRAME 324/6T IP23 ODP					
CHECKED							
RELEASED							
REL DT.			WMO Jaragua do Sul	Product Engineering	SHEET	1 / 1	

PREVIEW
WDD



WEG **W40 NEMA**
CC029A Premium
Inverter Duty Motor



IEC 60034-1
 MOD.T01#FOXON



For 60Hz use on PWM, VT 1000:1, CT 3:1, 1.0SF

MODEL 050180T3E326T-W40G
 MADE IN BRAZIL
 14504114

PH 3	FR 324/6T	HP(kW) 50.0(37.0)	Hz 60
V 230/460	A 117/58.5	RPM 1775	DES B
NEMA NOM EFF 94.5 %	INS. CL. F Δ T 80 K	IP23	
ENCL ODP	DUTY CONT.	AMB. 40°C	
CODE G	PF 0.84	SF 1.25	SFA 146/73.1
USABLE @208V	129 A	SF 1.15	SFA 148
40HP 30kW 50Hz 380V 58.0A 1475RPM SF1.00 EFF 93.6% (IE3)	ALT 1000 m.a.s.l.		

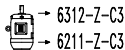
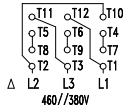
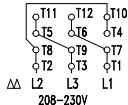

→ 6312-Z-C3
 → 6211-Z-C3

MOBIL POLYREX EM
 21 g 20000 h

ALT 1000 m.a.s.l. 511 Lbs