

DATA SHEET



Three Phase Induction Motor - Squirrel Cage

Customer :								
Product line		: NEMA Premium Efficiency Three-Phase			Product code :		11584360	
					Catalog # :		06009ST3QIE405T-W22	
Frame : 404/5T				Cooling method : IC411 - TEFC				
Insulation class : F				Mounting : F-1				
Duty cycle : Cont.(S1)				Rotation ¹ : Both (CW and CCW)				
Ambient temperature : -20°C to +40°C				Starting method : Direct On Line				
Altitude : 1000 m.a.s.l.				Approx. weight ² : 1157 lb				
Protection degree : IP55				Moment of inertia (J) : 40.2 sq.ft.lb				
Design : B								
Output [HP]	60	50	50	50	60	60	60	
Poles	8	8	8	8	8	8	8	
Frequency [Hz]	60	50	50	50	50	50	50	
Rated voltage [V]	460	380	400	415	380	400	415	
Rated current [A]	73.0	72.9	70.9	69.2	89.2	85.0	82.9	
L. R. Amperes [A]	475	445	475	505	455	485	514	
LRC [A]	6.5x(Code H)	6.1x(Code G)	6.7x(Code H)	7.3x(Code J)	5.1x(Code E)	5.7x(Code F)	6.2x(Code G)	
No load current [A]	30.0	29.7	32.0	33.9	29.7	32.0	33.9	
Rated speed [RPM]	880	725	730	730	720	725	725	
Slip [%]	2.22	3.33	2.67	2.67	4.00	3.33	3.33	
Rated torque [ft.lb]	358	362	360	360	438	435	435	
Locked rotor torque [%]	180	180	210	229	150	170	190	
Breakdown torque [%]	270	250	290	310	210	240	260	
Service factor	1.25	1.00	1.00	1.00	1.00	1.00	1.00	
Temperature rise	80 K	80 K	80 K	80 K	105 K	105 K	105 K	
Locked rotor time	23s (cold)	18s (cold)	18s (cold)	18s (cold)	18s (cold)	18s (cold)	18s (cold)	
	13s (hot)	10s (hot)	10s (hot)	10s (hot)	10s (hot)	10s (hot)	10s (hot)	
Noise level ²	60.0 dB(A)	56.0 dB(A)	56.0 dB(A)	56.0 dB(A)	56.0 dB(A)	56.0 dB(A)	56.0 dB(A)	
Efficiency (%)	25%							
	50%	93.0	92.4	91.9	91.9	92.4	92.4	
	75%	93.0	92.1	92.1	92.2	91.7	91.7	
	100%	93.0	91.8	91.8	91.8	90.2	91.0	
Power Factor	25%							
	50%	0.68	0.67	0.64	0.61	0.74	0.71	
	75%	0.78	0.79	0.77	0.74	0.82	0.80	
	100%	0.83	0.84	0.82	0.81	0.85	0.84	
Bearing type	Drive end		Non drive end		Foundation loads			
	: 6316 C3		: 6314 C3		Max. traction : 2813 lb			
	: Inpro/Seal		: Inpro/Seal		Max. compression : 3971 lb			
	: 20000 h		: 20000 h					
	: 34 g		: 27 g					
Lubricant type		: Mobil Polyrex EM						
Notes								
This revision replaces and cancel the previous one, which must be eliminated. (1) Looking the motor from the shaft end. (2) Measured at 1m and with tolerance of +3dB(A). (3) Approximate weight subject to changes after manufacturing process. (4) At 100% of full load.				These are average values based on tests with sinusoidal power supply, subject to the tolerances stipulated in NEMA MG-1.				
Rev.	Changes Summary			Performed	Checked	Date		
Performed by								
Checked by					Page	Revision		
Date	12/04/2022				1 / 36			

TORQUE AND CURRENT VS SPEED CURVE

Three Phase Induction Motor - Squirrel Cage



Customer :

Product line : NEMA Premium Efficiency Three-Phase

Product code : 11584360

Catalog # : 06009ST3QIE405T-W22

TORQUE AND CURRENT VS SPEED CURVE

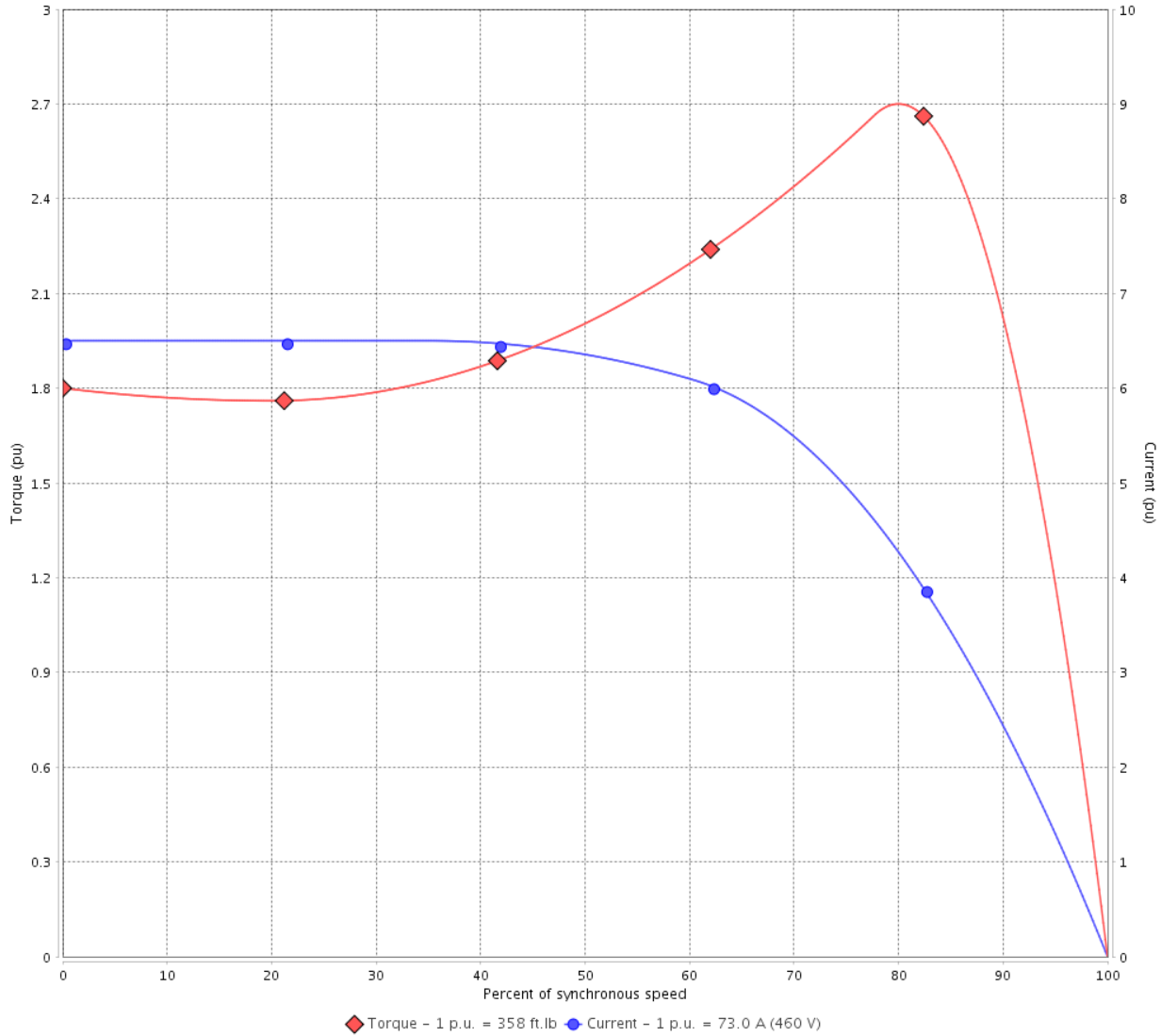

Performance : 460 V 60 Hz 8P

Rated current	: 73.0 A	Moment of inertia (J)	: 40.2 sq.ft.lb
LRC	: 6.5	Duty cycle	: Cont.(S1)
Rated torque	: 358 ft.lb	Insulation class	: F
Locked rotor torque	: 180 %	Service factor	: 1.25
Breakdown torque	: 270 %	Temperature rise	: 80 K
Rated speed	: 880 rpm	Design	: B

Locked rotor time : 23s (cold) 13s (hot)

Rev.	Changes Summary	Performed	Checked	Date
Performed by			Page 2 / 36	Revision
Checked by				
Date	12/04/2022			

TORQUE AND CURRENT VS SPEED CURVE



Three Phase Induction Motor - Squirrel Cage

Customer :

Product line : NEMA Premium Efficiency Three-Phase

Product code : 11584360

Catalog # : 06009ST3QIE405T-W22

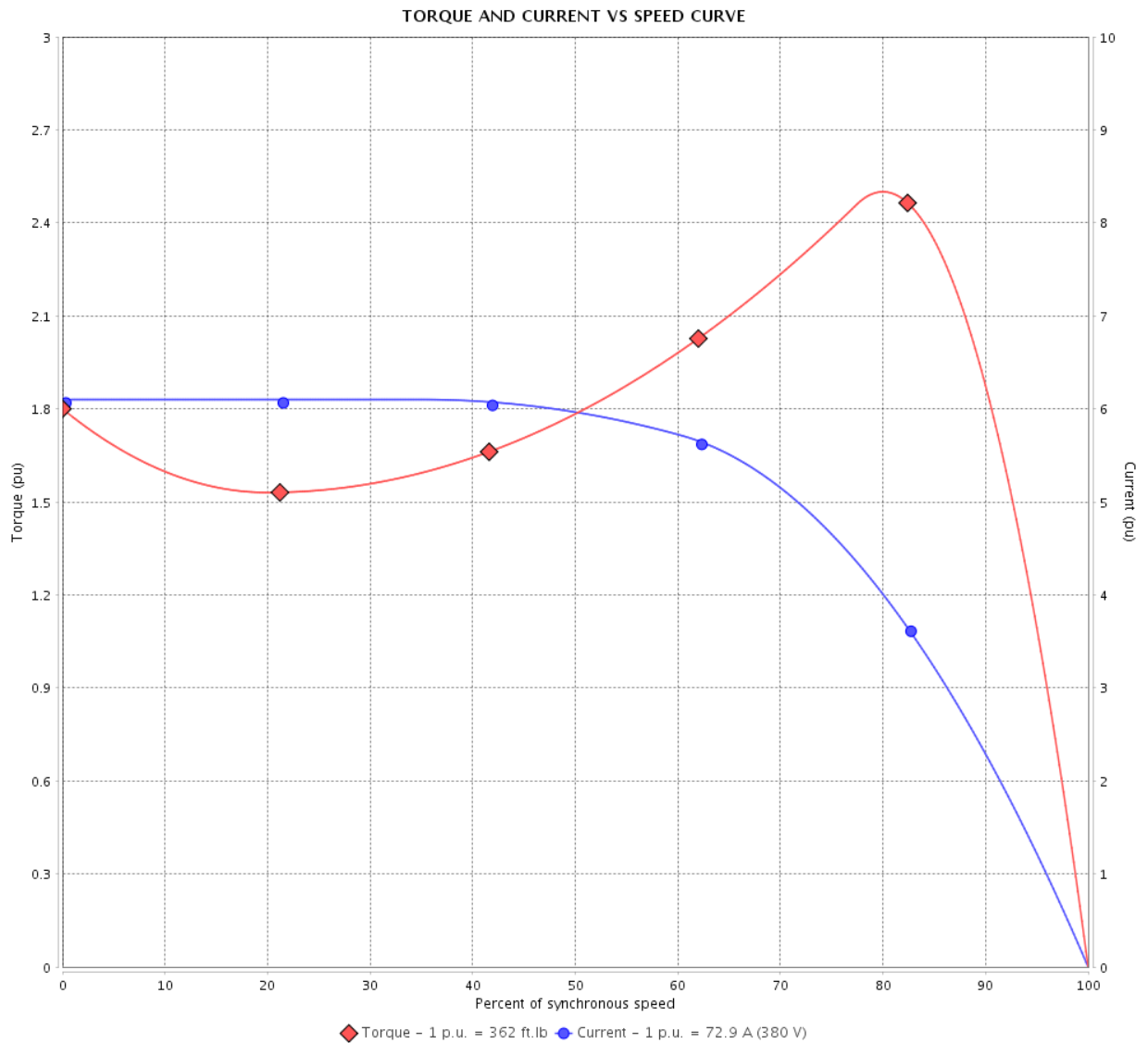

Performance : 380 V 50 Hz 8P IE3

Rated current	: 72.9 A	Moment of inertia (J)	: 40.2 sq.ft.lb
LRC	: 6.1	Duty cycle	: Cont.(S1)
Rated torque	: 362 ft.lb	Insulation class	: F
Locked rotor torque	: 180 %	Service factor	: 1.00
Breakdown torque	: 250 %	Temperature rise	: 80 K
Rated speed	: 725 rpm	Design	: B

Locked rotor time : 18s (cold) 10s (hot)

Rev.	Changes Summary	Performed	Checked	Date
Performed by			Page 3 / 36	Revision
Checked by				
Date	12/04/2022			

TORQUE AND CURRENT VS SPEED CURVE

Three Phase Induction Motor - Squirrel Cage



Customer :

Product line : NEMA Premium Efficiency Three-Phase

Product code : 11584360

Catalog # : 06009ST3QIE405T-W22

TORQUE AND CURRENT VS SPEED CURVE

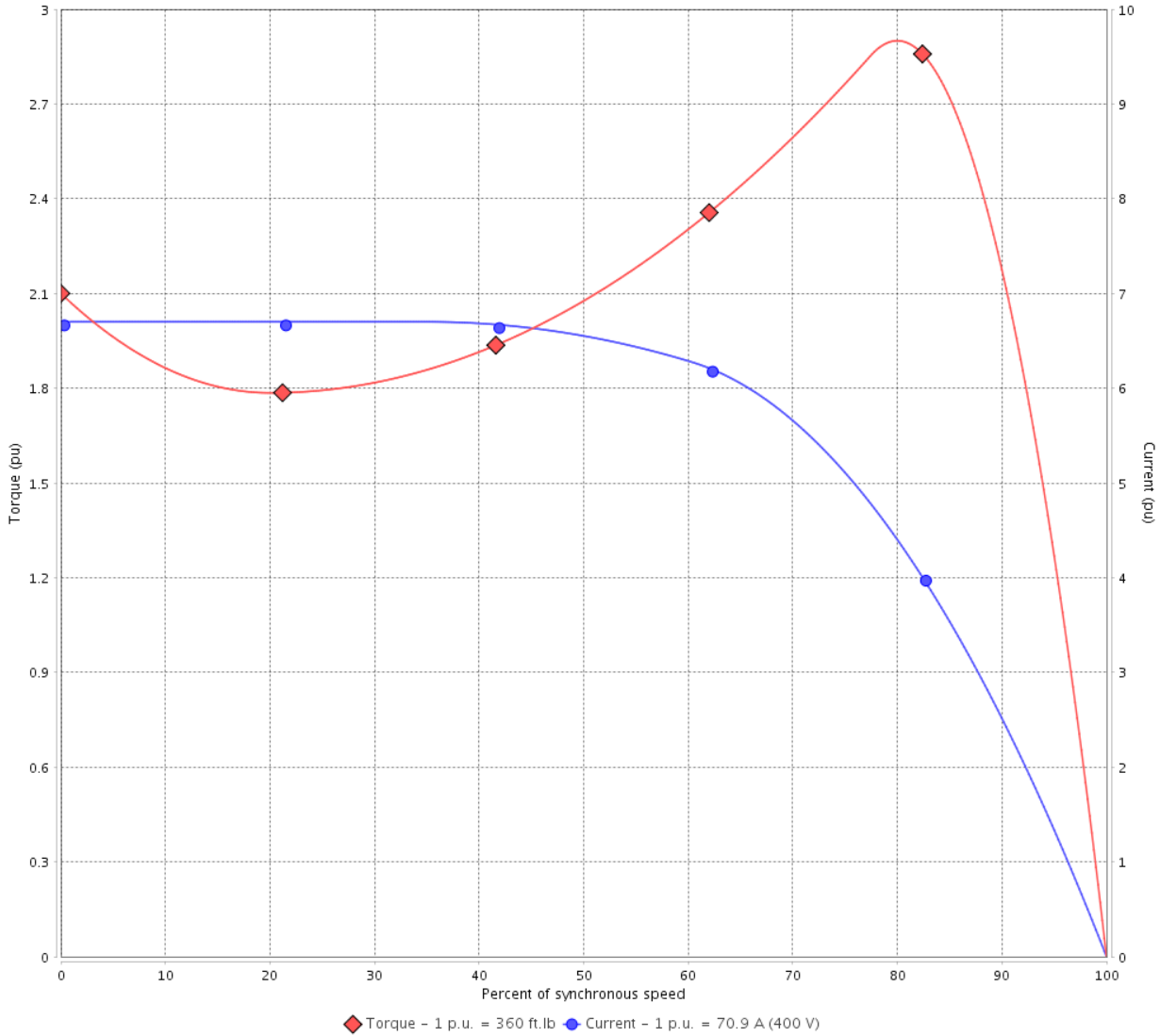

Performance : 400 V 50 Hz 8P IE3

Rated current	: 70.9 A	Moment of inertia (J)	: 40.2 sq.ft.lb
LRC	: 6.7	Duty cycle	: Cont.(S1)
Rated torque	: 360 ft.lb	Insulation class	: F
Locked rotor torque	: 210 %	Service factor	: 1.00
Breakdown torque	: 290 %	Temperature rise	: 80 K
Rated speed	: 730 rpm	Design	: B

Locked rotor time : 18s (cold) 10s (hot)

Rev.	Changes Summary	Performed	Checked	Date
Performed by			Page 4 / 36	Revision
Checked by				
Date	12/04/2022			

TORQUE AND CURRENT VS SPEED CURVE



Three Phase Induction Motor - Squirrel Cage

Customer :

Product line : NEMA Premium Efficiency Three-Phase

Product code : 11584360

Catalog # : 06009ST3QIE405T-W22

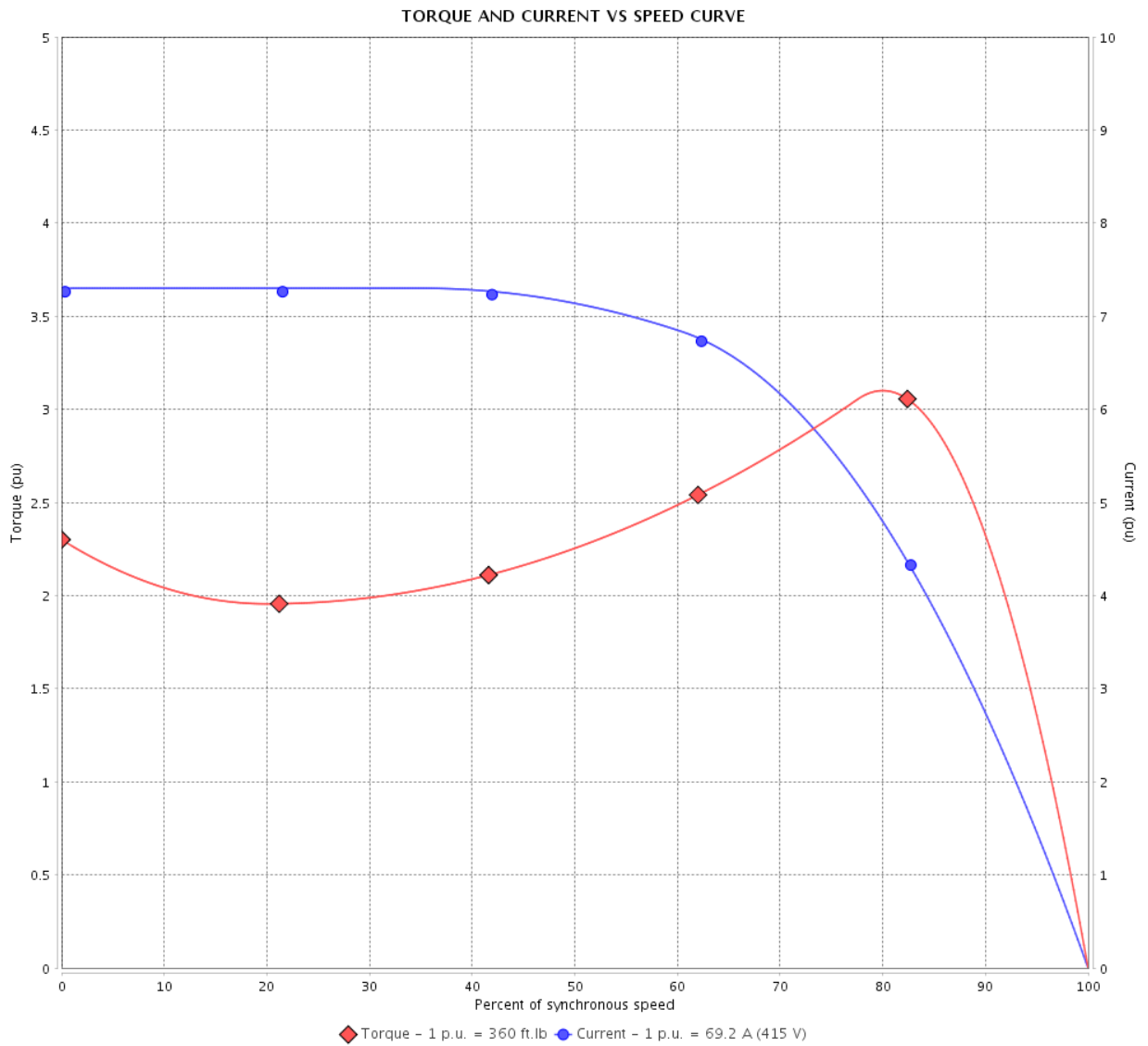

Performance : 415 V 50 Hz 8P IE3

Rated current	: 69.2 A	Moment of inertia (J)	: 40.2 sq.ft.lb
LRC	: 7.3	Duty cycle	: Cont.(S1)
Rated torque	: 360 ft.lb	Insulation class	: F
Locked rotor torque	: 229 %	Service factor	: 1.00
Breakdown torque	: 310 %	Temperature rise	: 80 K
Rated speed	: 730 rpm	Design	: B

Locked rotor time : 18s (cold) 10s (hot)

Rev.	Changes Summary	Performed	Checked	Date
Performed by			Page 5 / 36	Revision
Checked by				
Date	12/04/2022			

TORQUE AND CURRENT VS SPEED CURVE

Three Phase Induction Motor - Squirrel Cage



Customer :

Product line : NEMA Premium Efficiency Three-Phase

Product code : 11584360

Catalog # : 06009ST3QIE405T-W22

TORQUE AND CURRENT VS SPEED CURVE

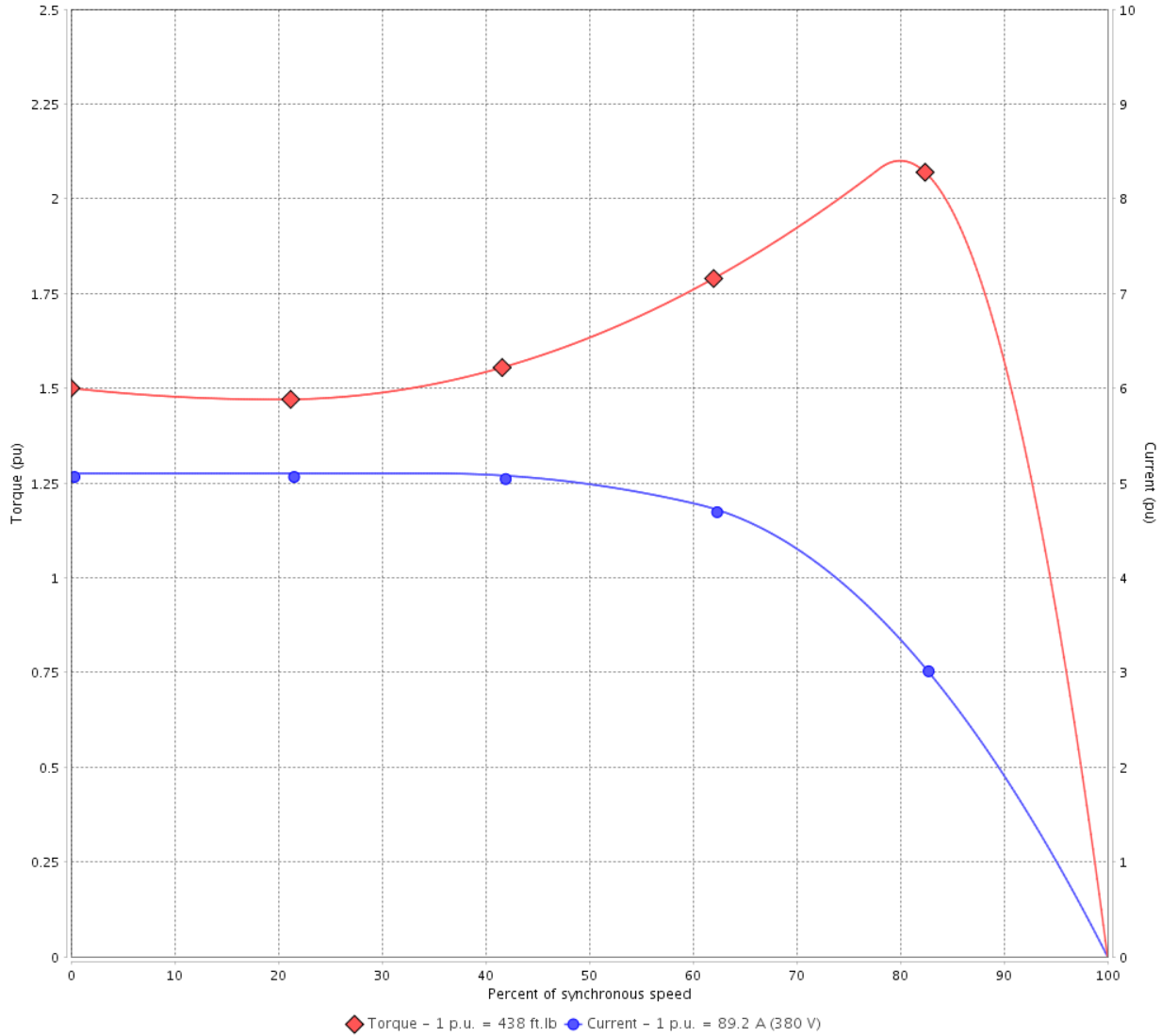

Performance : 380 V 50 Hz 8P IE1

Rated current	: 89.2 A	Moment of inertia (J)	: 40.2 sq.ft.lb
LRC	: 5.1	Duty cycle	: Cont.(S1)
Rated torque	: 438 ft.lb	Insulation class	: F
Locked rotor torque	: 150 %	Service factor	: 1.00
Breakdown torque	: 210 %	Temperature rise	: 105 K
Rated speed	: 720 rpm	Design	: B

Locked rotor time : 18s (cold) 10s (hot)

Rev.	Changes Summary	Performed	Checked	Date
Performed by			Page 6 / 36	Revision
Checked by				
Date	12/04/2022			

TORQUE AND CURRENT VS SPEED CURVE



Three Phase Induction Motor - Squirrel Cage

Customer :

Product line : NEMA Premium Efficiency Three-Phase

Product code : 11584360

Catalog # : 06009ST3QIE405T-W22

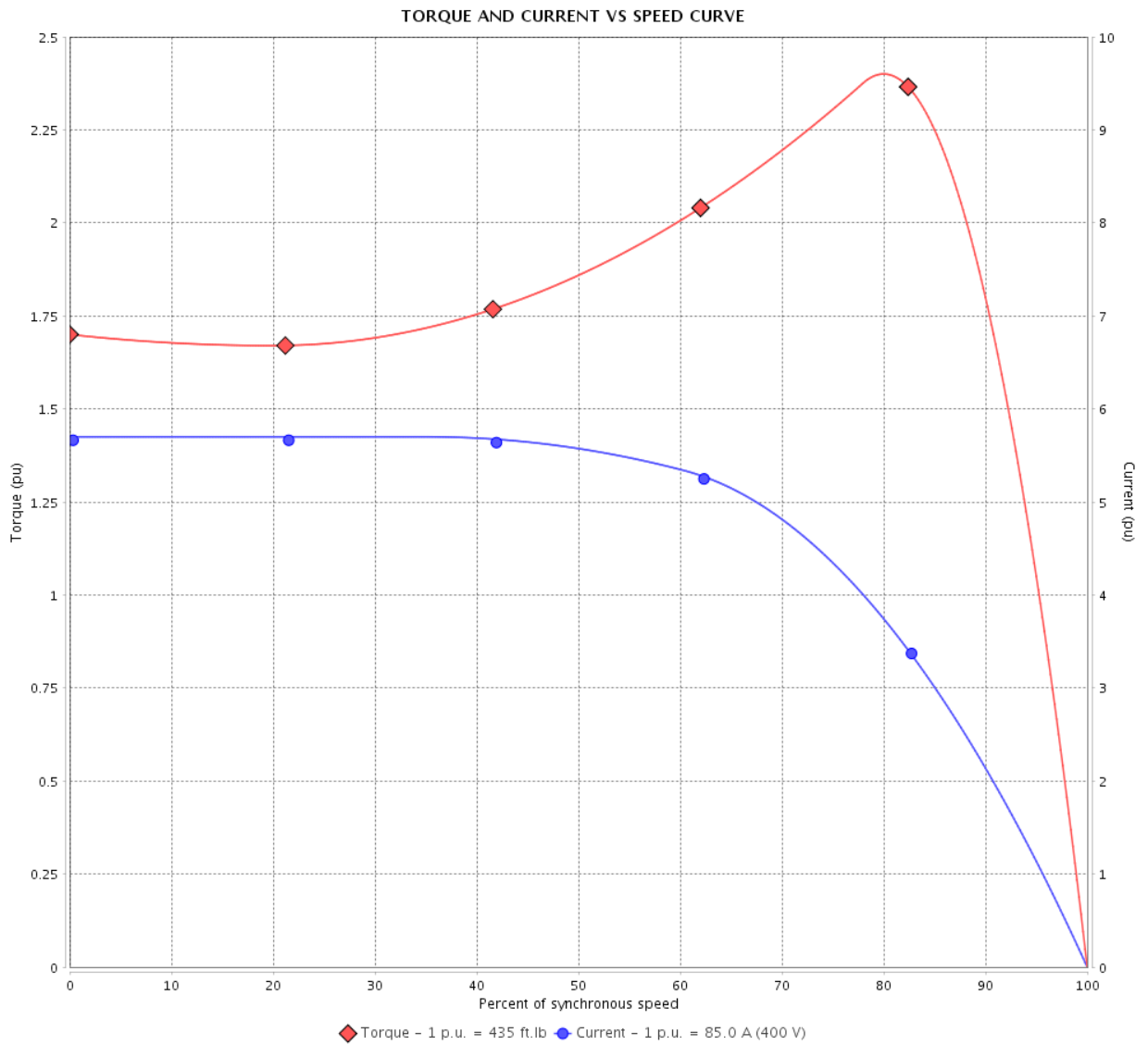

Performance : 400 V 50 Hz 8P IE2

Rated current	: 85.0 A	Moment of inertia (J)	: 40.2 sq.ft.lb
LRC	: 5.7	Duty cycle	: Cont.(S1)
Rated torque	: 435 ft.lb	Insulation class	: F
Locked rotor torque	: 170 %	Service factor	: 1.00
Breakdown torque	: 240 %	Temperature rise	: 105 K
Rated speed	: 725 rpm	Design	: B

Locked rotor time : 18s (cold) 10s (hot)

Rev.	Changes Summary	Performed	Checked	Date
Performed by			Page 7 / 36	Revision
Checked by				
Date	12/04/2022			

TORQUE AND CURRENT VS SPEED CURVE

Three Phase Induction Motor - Squirrel Cage



Customer :

Product line : NEMA Premium Efficiency Three-Phase

Product code : 11584360

Catalog # : 06009ST3QIE405T-W22

TORQUE AND CURRENT VS SPEED CURVE

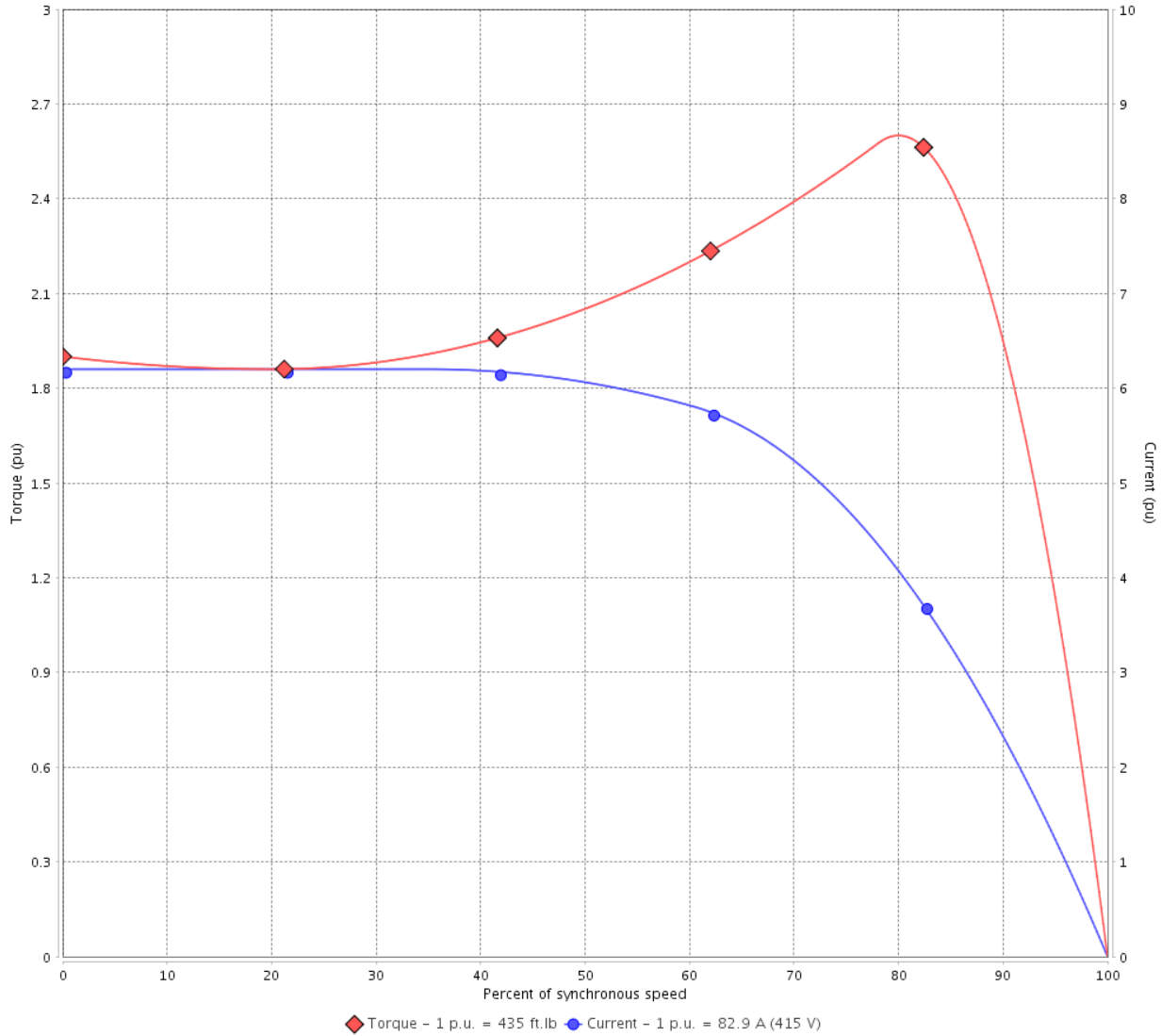

Performance : 415 V 50 Hz 8P IE2

Rated current	: 82.9 A	Moment of inertia (J)	: 40.2 sq.ft.lb
LRC	: 6.2	Duty cycle	: Cont.(S1)
Rated torque	: 435 ft.lb	Insulation class	: F
Locked rotor torque	: 190 %	Service factor	: 1.00
Breakdown torque	: 260 %	Temperature rise	: 105 K
Rated speed	: 725 rpm	Design	: B

Locked rotor time : 18s (cold) 10s (hot)

Rev.	Changes Summary	Performed	Checked	Date
Performed by			Page 8 / 36	Revision
Checked by				
Date	12/04/2022			

LOAD PERFORMANCE CURVE

Three Phase Induction Motor - Squirrel Cage



Customer :

Product line : NEMA Premium Efficiency Three-Phase

Product code : 11584360

Catalog # : 06009ST3QIE405T-W22

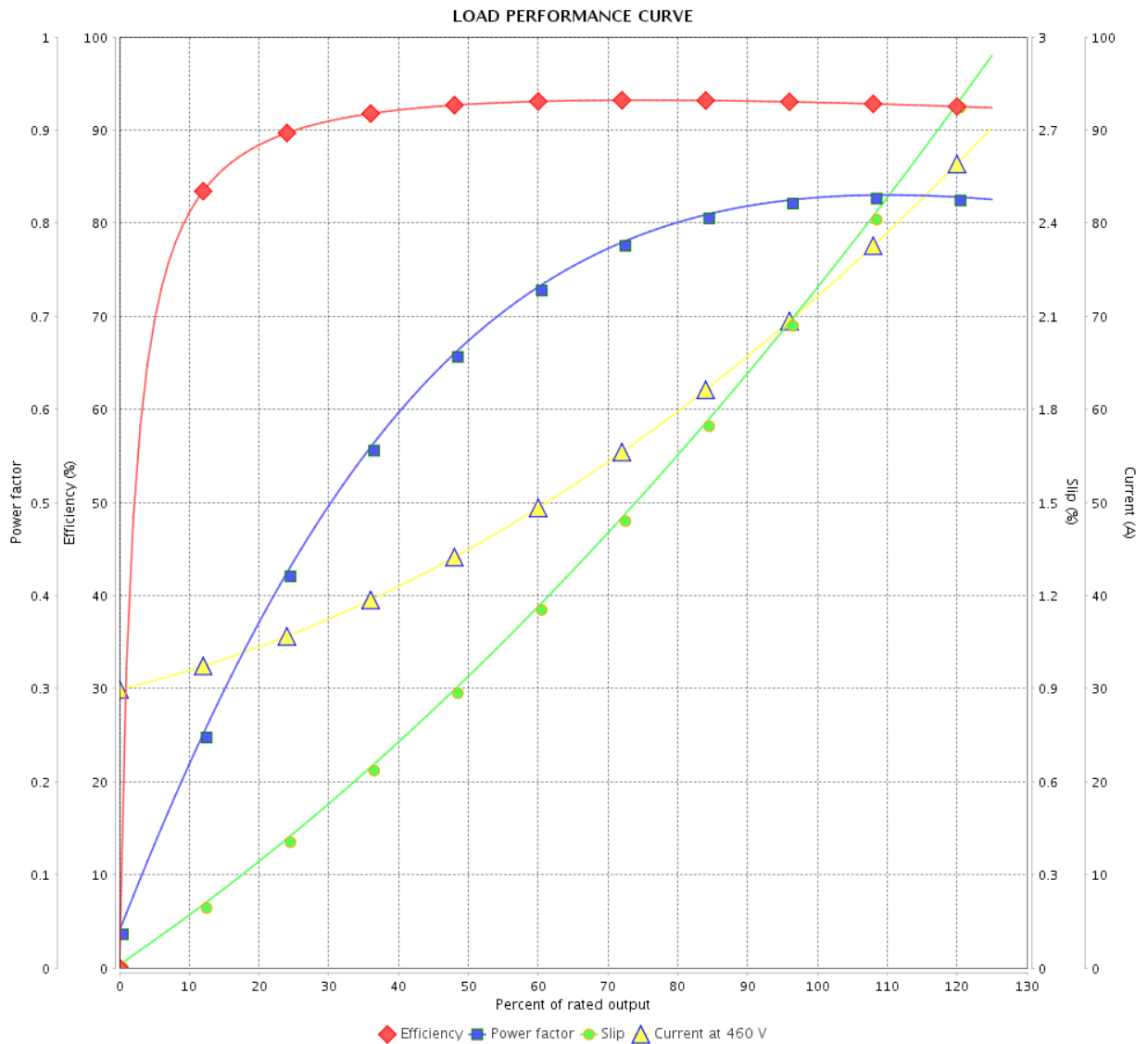

Performance : 460 V 60 Hz 8P

Rated current : 73.0 A
 LRC : 6.5
 Rated torque : 358 ft.lb
 Locked rotor torque : 180 %
 Breakdown torque : 270 %
 Rated speed : 880 rpm

Moment of inertia (J) : 40.2 sq.ft.lb
 Duty cycle : Cont.(S1)
 Insulation class : F
 Service factor : 1.25
 Temperature rise : 80 K
 Design : B

Rev.	Changes Summary	Performed	Checked	Date
Performed by			Page	Revision
Checked by			9 / 36	
Date	12/04/2022			

LOAD PERFORMANCE CURVE

Three Phase Induction Motor - Squirrel Cage



Customer :

Product line : NEMA Premium Efficiency Three-Phase

Product code : 11584360

Catalog # : 06009ST3QIE405T-W22

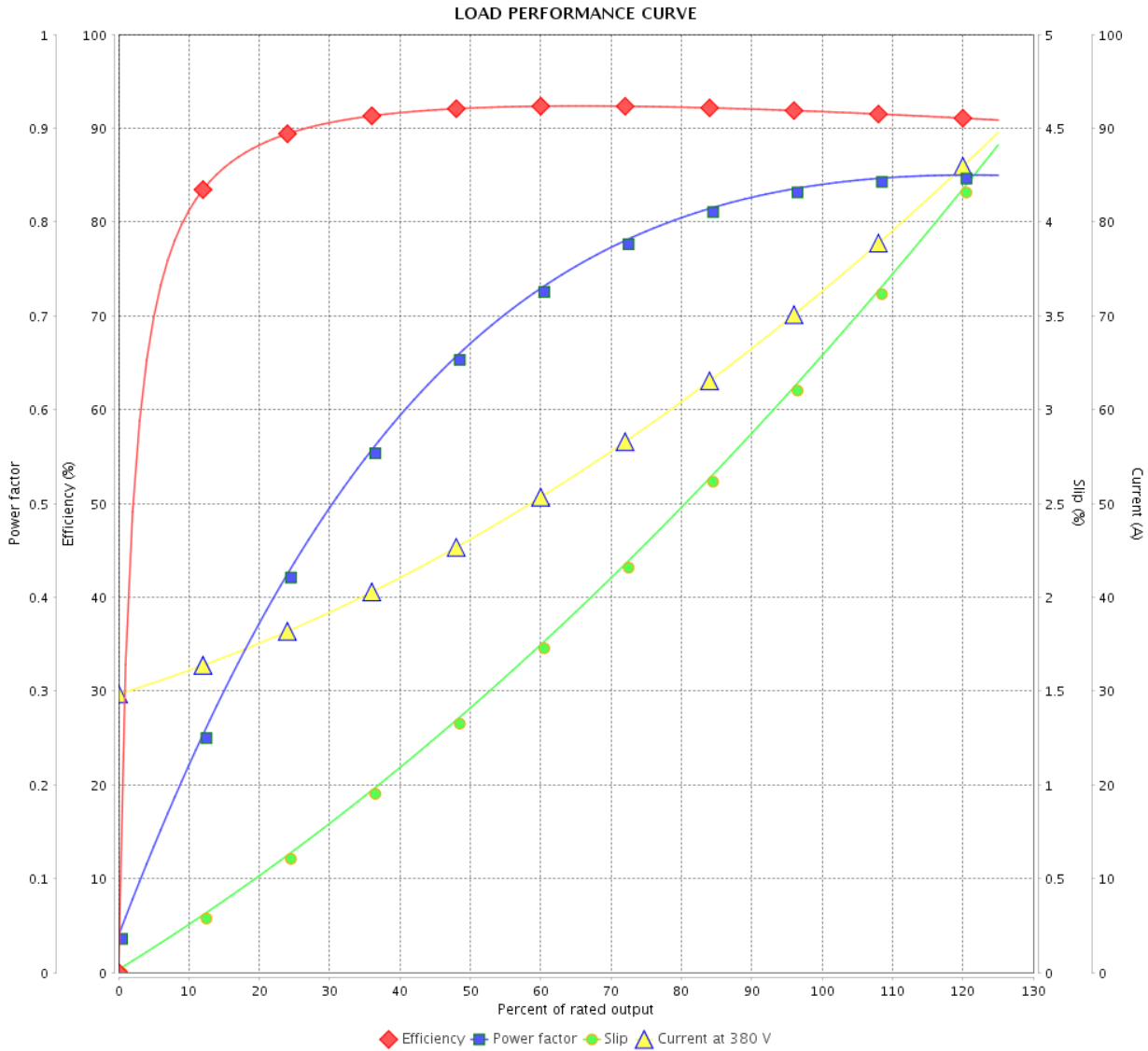

Performance : 380 V 50 Hz 8P IE3

Rated current : 72.9 A
 LRC : 6.1
 Rated torque : 362 ft.lb
 Locked rotor torque : 180 %
 Breakdown torque : 250 %
 Rated speed : 725 rpm

Moment of inertia (J) : 40.2 sq.ft.lb
 Duty cycle : Cont.(S1)
 Insulation class : F
 Service factor : 1.00
 Temperature rise : 80 K
 Design : B

Rev.	Changes Summary	Performed	Checked	Date
Performed by		Page		Revision
Checked by		10 / 36		
Date		12/04/2022		

LOAD PERFORMANCE CURVE

Three Phase Induction Motor - Squirrel Cage



Customer : _____

Product line : NEMA Premium Efficiency Three-Phase

Product code : 11584360

Catalog # : 06009ST3QIE405T-W22

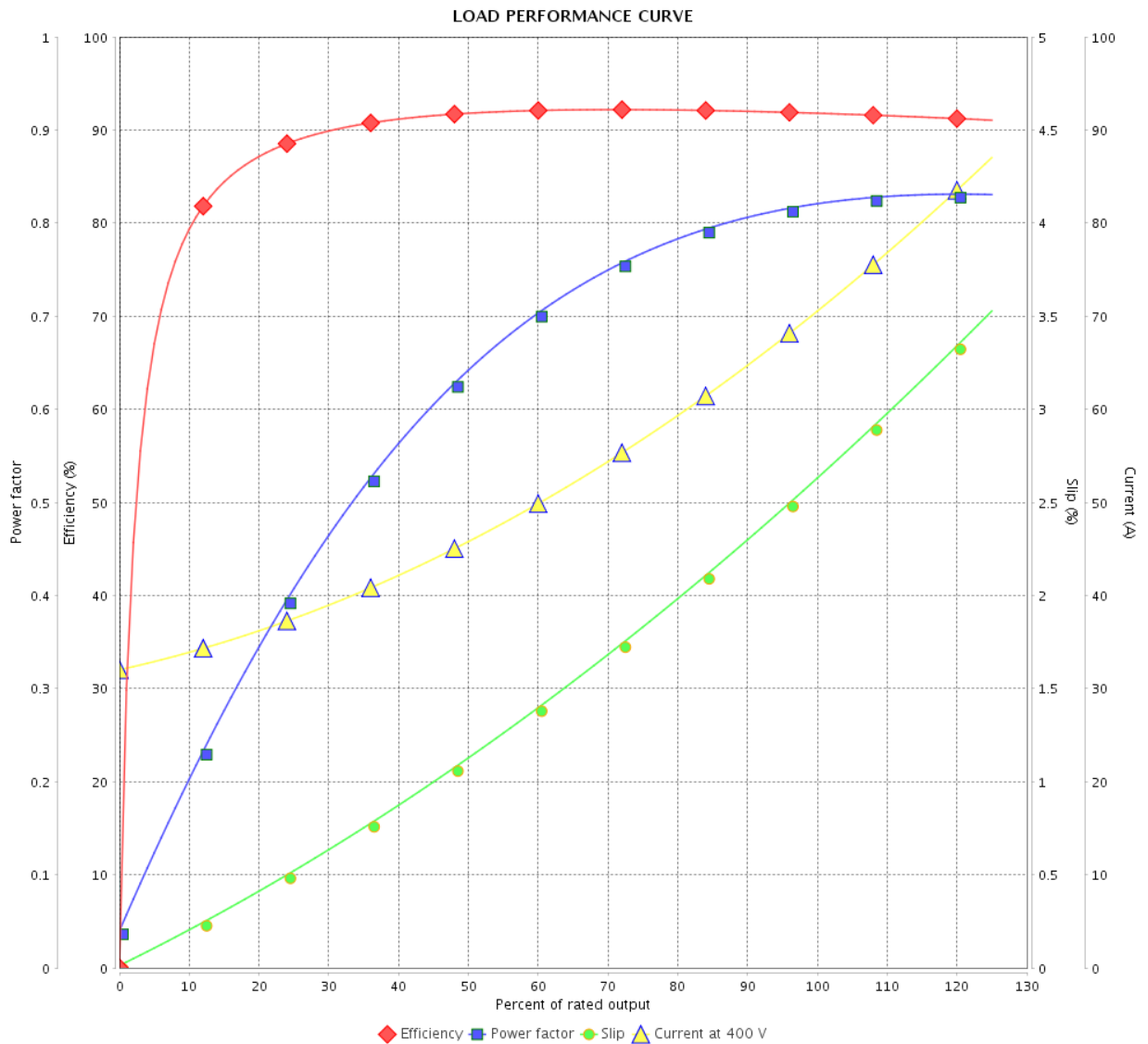

Performance : 400 V 50 Hz 8P IE3

Rated current : 70.9 A
 LRC : 6.7
 Rated torque : 360 ft.lb
 Locked rotor torque : 210 %
 Breakdown torque : 290 %
 Rated speed : 730 rpm

Moment of inertia (J) : 40.2 sq.ft.lb
 Duty cycle : Cont.(S1)
 Insulation class : F
 Service factor : 1.00
 Temperature rise : 80 K
 Design : B

Rev.	Changes Summary	Performed	Checked	Date
Performed by		Page		Revision
Checked by		11 / 36		
Date		12/04/2022		

LOAD PERFORMANCE CURVE

Three Phase Induction Motor - Squirrel Cage



Customer :

Product line : NEMA Premium Efficiency Three-Phase

Product code : 11584360

Catalog # : 06009ST3QIE405T-W22

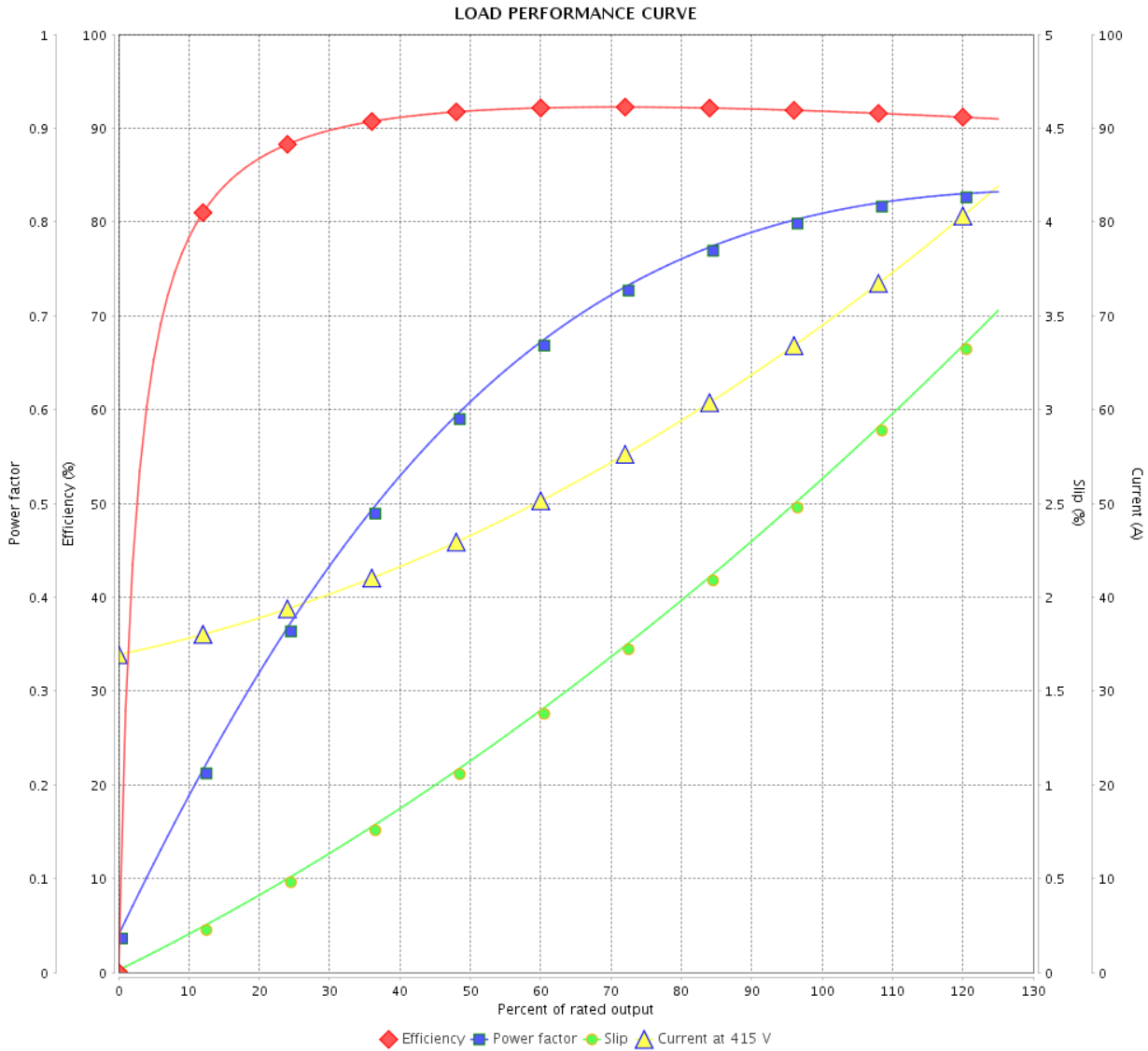

Performance : 415 V 50 Hz 8P IE3

Rated current	: 69.2 A	Moment of inertia (J)	: 40.2 sq.ft.lb
LRC	: 7.3	Duty cycle	: Cont.(S1)
Rated torque	: 360 ft.lb	Insulation class	: F
Locked rotor torque	: 229 %	Service factor	: 1.00
Breakdown torque	: 310 %	Temperature rise	: 80 K
Rated speed	: 730 rpm	Design	: B

Rev.	Changes Summary	Performed	Checked	Date
Performed by			Page	Revision
Checked by			12 / 36	
Date	12/04/2022			

LOAD PERFORMANCE CURVE

Three Phase Induction Motor - Squirrel Cage



Customer :

Product line : NEMA Premium Efficiency Three-Phase

Product code : 11584360

Catalog # : 06009ST3QIE405T-W22

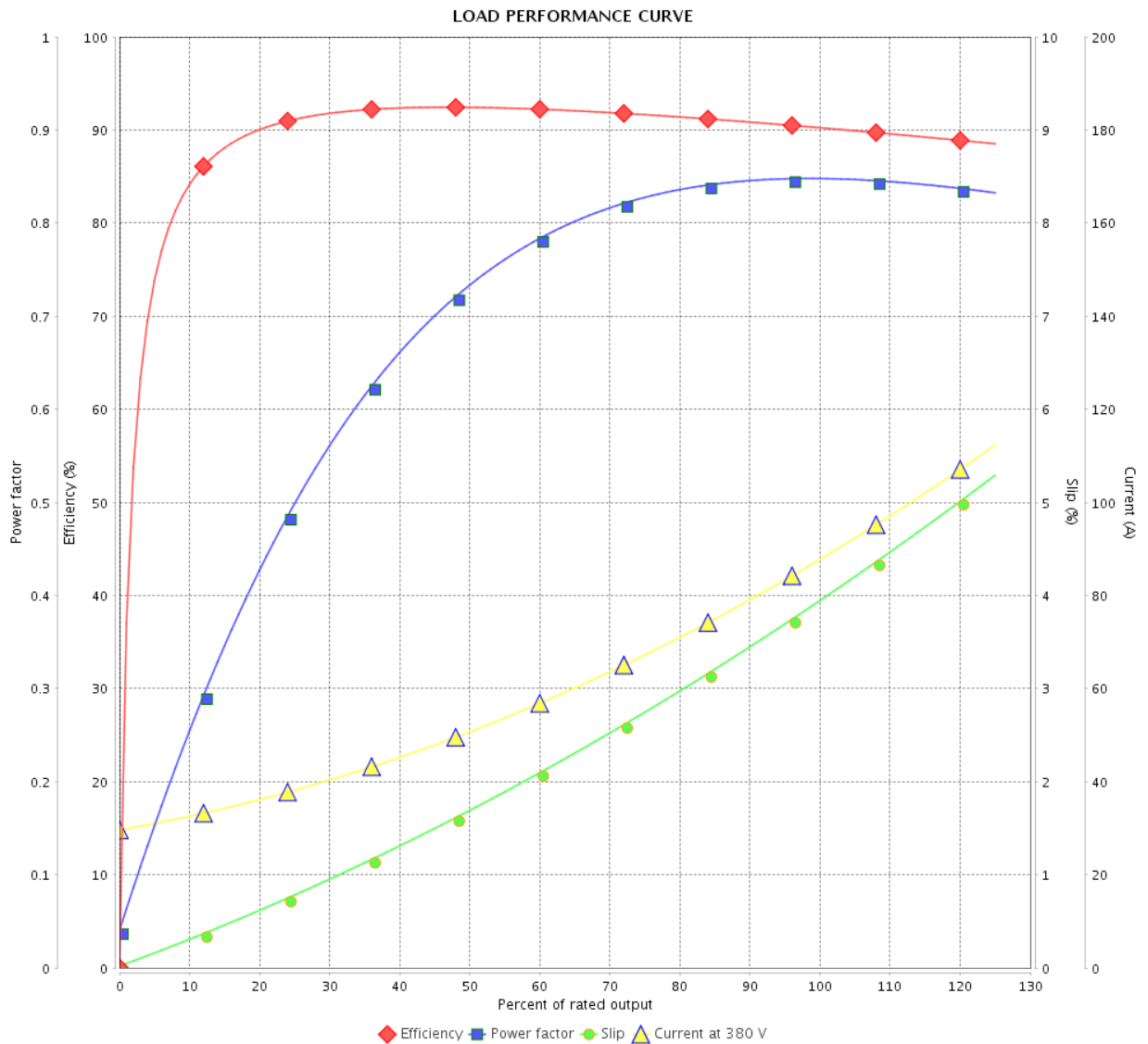

Performance : 380 V 50 Hz 8P IE1

Rated current : 89.2 A
 LRC : 5.1
 Rated torque : 438 ft.lb
 Locked rotor torque : 150 %
 Breakdown torque : 210 %
 Rated speed : 720 rpm

Moment of inertia (J) : 40.2 sq.ft.lb
 Duty cycle : Cont.(S1)
 Insulation class : F
 Service factor : 1.00
 Temperature rise : 105 K
 Design : B

Rev.	Changes Summary	Performed	Checked	Date
Performed by		Page		Revision
Checked by		13 / 36		
Date		12/04/2022		

LOAD PERFORMANCE CURVE

Three Phase Induction Motor - Squirrel Cage



Customer : _____

Product line : NEMA Premium Efficiency Three-Phase

Product code : 11584360

Catalog # : 06009ST3QIE405T-W22

LOAD PERFORMANCE CURVE

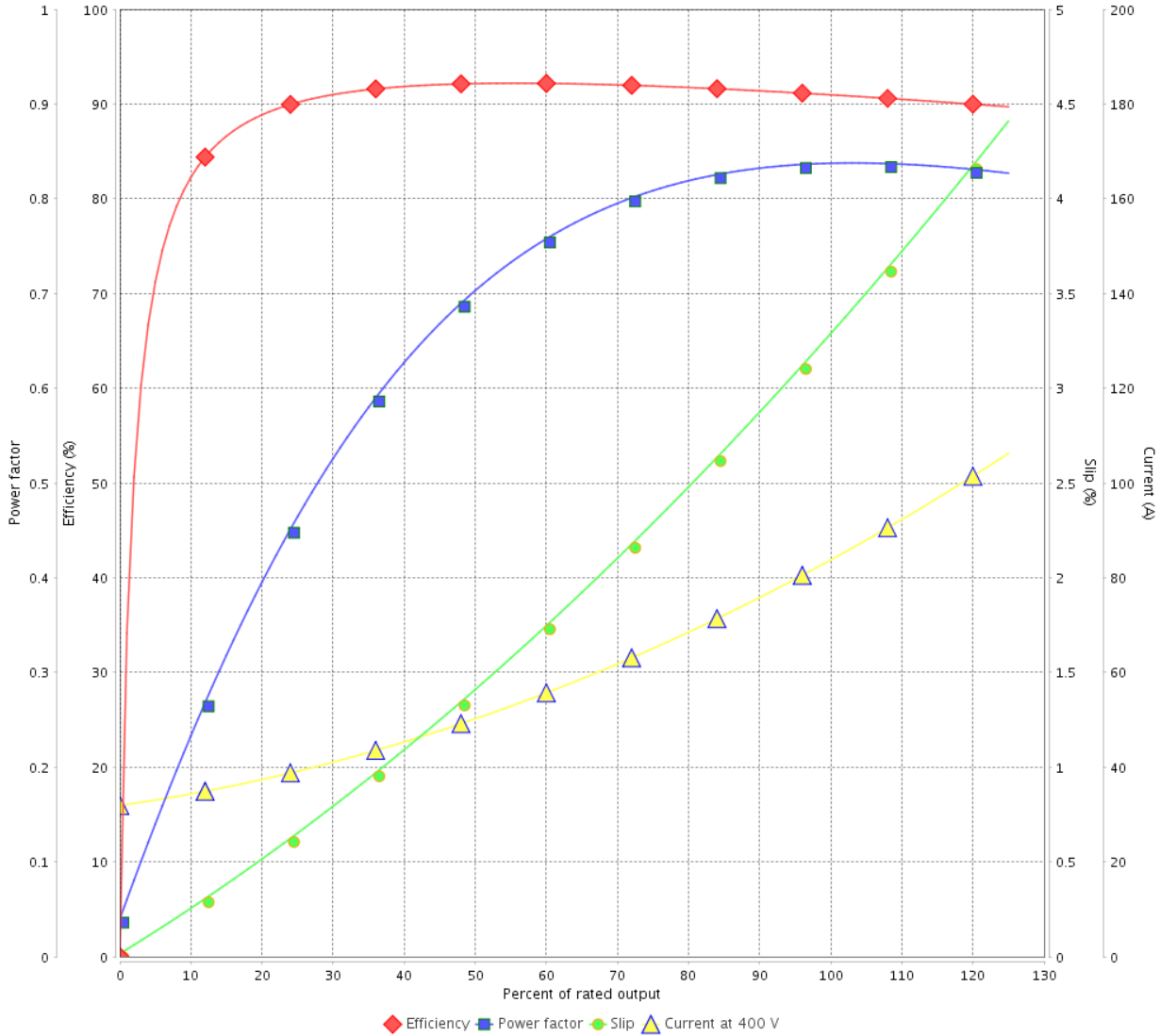

Performance : 400 V 50 Hz 8P IE2

Rated current : 85.0 A
 LRC : 5.7
 Rated torque : 435 ft.lb
 Locked rotor torque : 170 %
 Breakdown torque : 240 %
 Rated speed : 725 rpm

Moment of inertia (J) : 40.2 sq.ft.lb
 Duty cycle : Cont.(S1)
 Insulation class : F
 Service factor : 1.00
 Temperature rise : 105 K
 Design : B

Rev.	Changes Summary	Performed	Checked	Date
Performed by			Page 14 / 36	Revision
Checked by				
Date	12/04/2022			

LOAD PERFORMANCE CURVE

Three Phase Induction Motor - Squirrel Cage



Customer :

Product line : NEMA Premium Efficiency Three-Phase

Product code : 11584360

Catalog # : 06009ST3QIE405T-W22

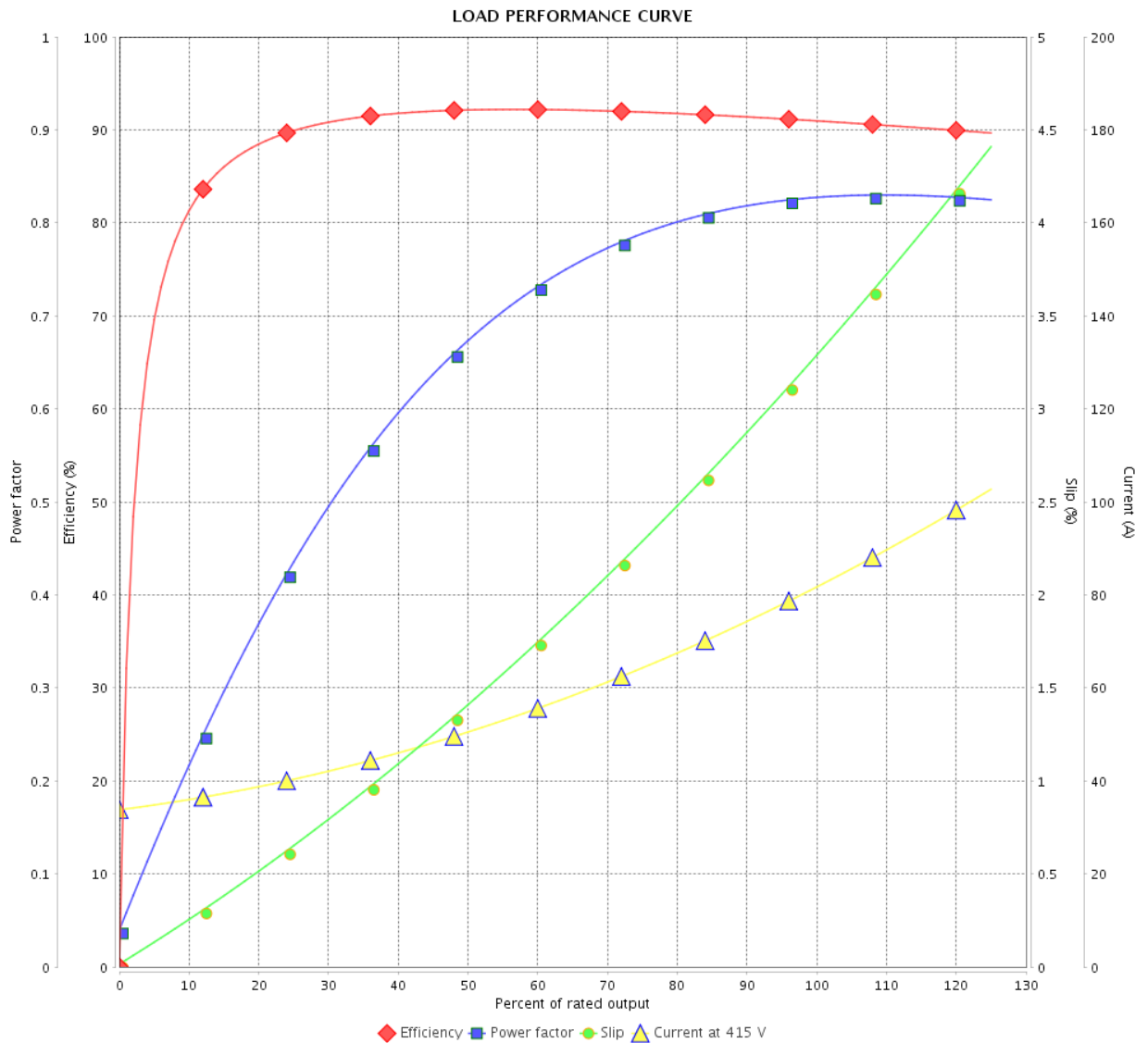

Performance : 415 V 50 Hz 8P IE2

Rated current : 82.9 A
 LRC : 6.2
 Rated torque : 435 ft.lb
 Locked rotor torque : 190 %
 Breakdown torque : 260 %
 Rated speed : 725 rpm

Moment of inertia (J) : 40.2 sq.ft.lb
 Duty cycle : Cont.(S1)
 Insulation class : F
 Service factor : 1.00
 Temperature rise : 105 K
 Design : B

Rev.	Changes Summary	Performed	Checked	Date
Performed by		Page		Revision
Checked by		15 / 36		
Date		12/04/2022		

THERMAL LIMIT CURVE



Three Phase Induction Motor - Squirrel Cage

Customer :

Product line : NEMA Premium Efficiency Three-Phase
 Product code : 11584360
 Catalog # : 06009ST3QIE405T-W22

Performance : 460 V 60 Hz 8P

Rated current : 73.0 A	Moment of inertia (J) : 40.2 sq.ft.lb
LRC : 6.5	Duty cycle : Cont.(S1)
Rated torque : 358 ft.lb	Insulation class : F
Locked rotor torque : 180 %	Service factor : 1.25
Breakdown torque : 270 %	Temperature rise : 80 K
Rated speed : 880 rpm	Design : B

Heating constant

Cooling constant

Rev.	Changes Summary	Performed	Checked	Date
Performed by			Page 16 / 36	Revision
Checked by				
Date	12/04/2022			

THERMAL LIMIT CURVE

Three Phase Induction Motor - Squirrel Cage



Customer : _____

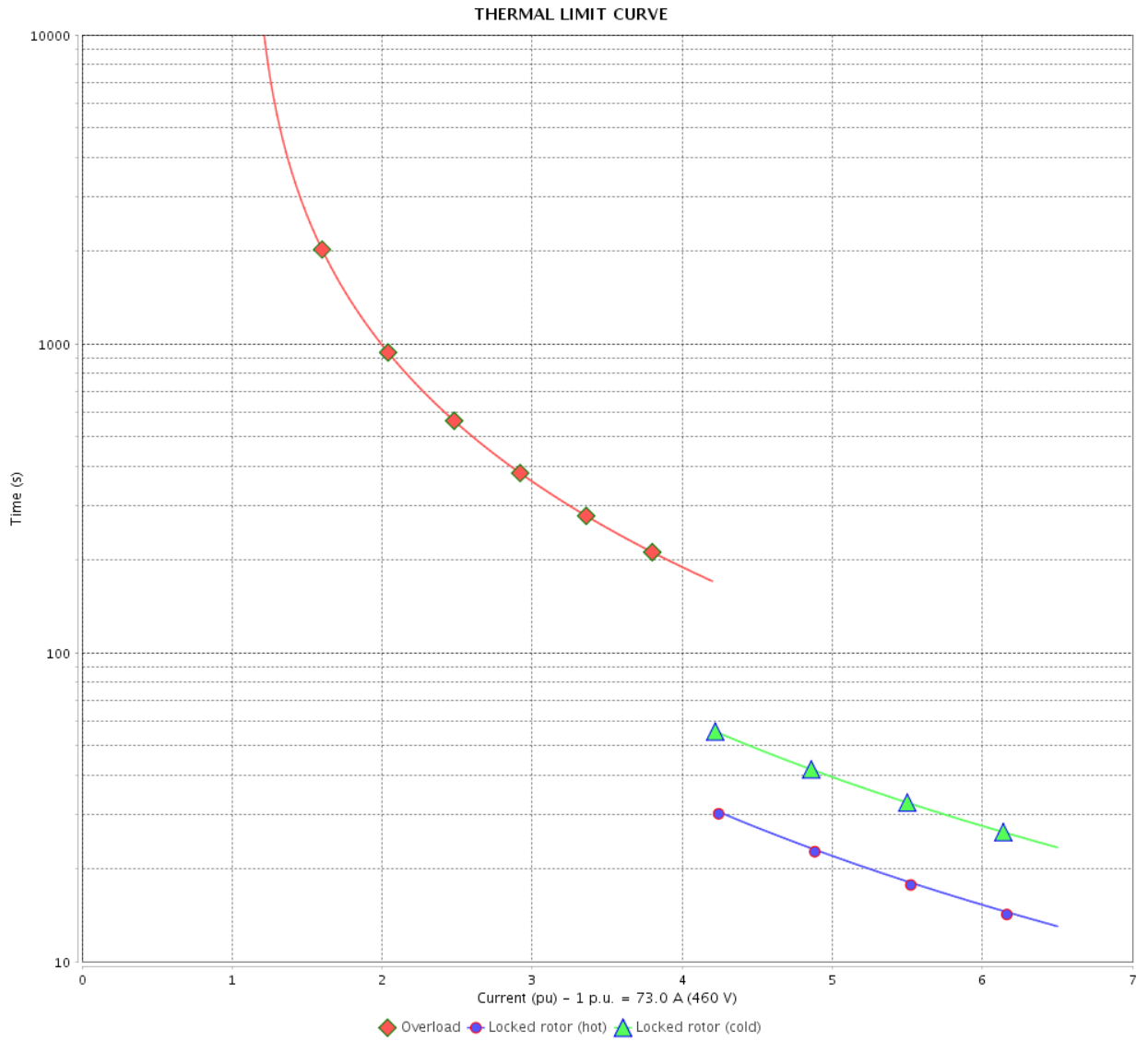

Rev.	Changes Summary	Performed	Checked	Date
Performed by		Page		Revision
Checked by		17 / 36		
Date		12/04/2022		

THERMAL LIMIT CURVE



Three Phase Induction Motor - Squirrel Cage

Customer :

Product line : NEMA Premium Efficiency Three-Phase
Product code : 11584360
Catalog # : 06009ST3QIE405T-W22

Performance : 380 V 50 Hz 8P IE3

Rated current	: 72.9 A	Moment of inertia (J)	: 40.2 sq.ft.lb
LRC	: 6.1	Duty cycle	: Cont.(S1)
Rated torque	: 362 ft.lb	Insulation class	: F
Locked rotor torque	: 180 %	Service factor	: 1.00
Breakdown torque	: 250 %	Temperature rise	: 80 K
Rated speed	: 725 rpm	Design	: B

Heating constant

Cooling constant

Rev.	Changes Summary	Performed	Checked	Date
Performed by				
Checked by			Page	Revision
Date	12/04/2022		18 / 36	

THERMAL LIMIT CURVE

Three Phase Induction Motor - Squirrel Cage



Customer : _____

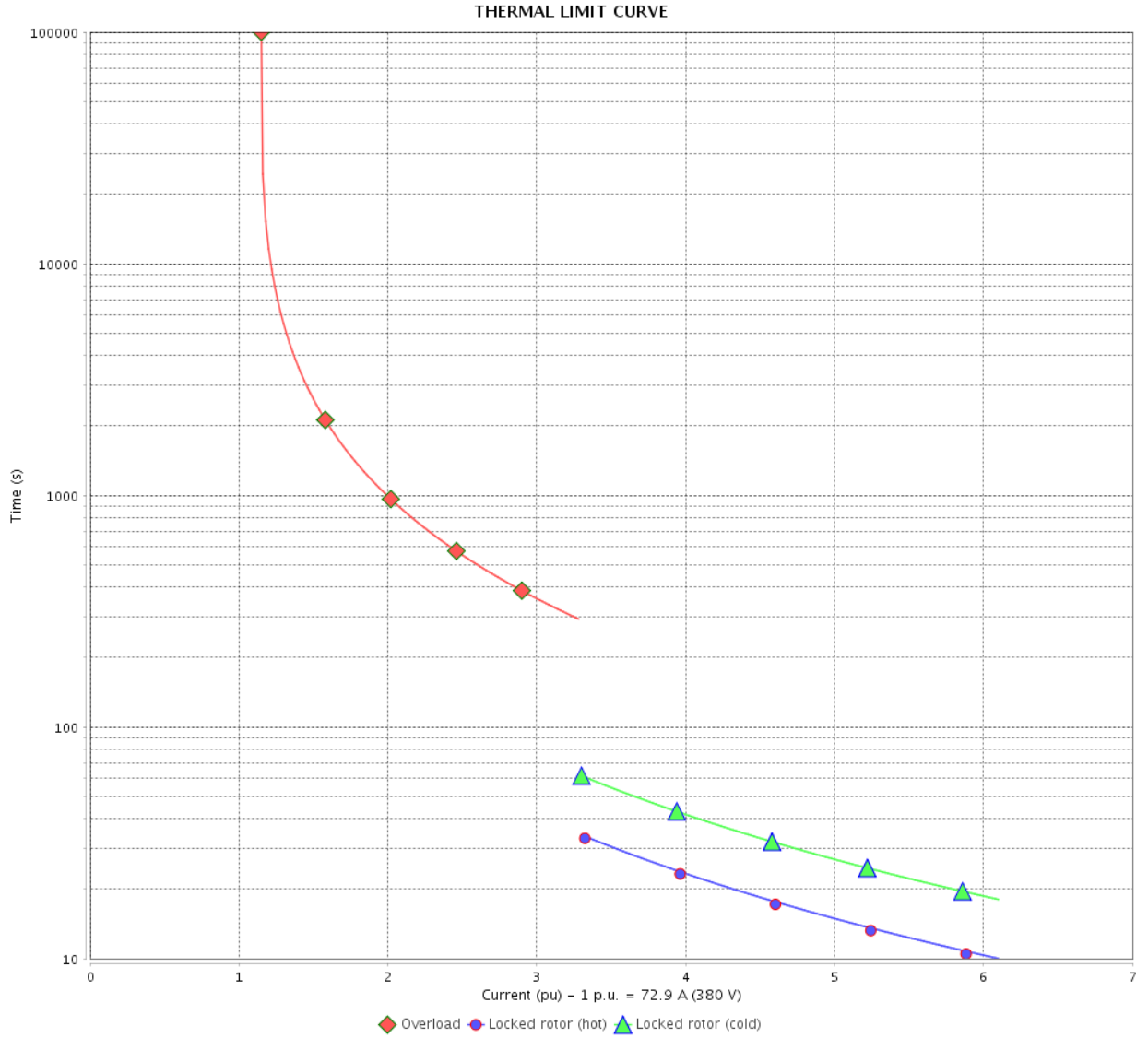

Rev.	Changes Summary	Performed	Checked	Date
Performed by		Page 19 / 36		Revision
Checked by				
Date				

THERMAL LIMIT CURVE



Three Phase Induction Motor - Squirrel Cage

Customer :

Product line : NEMA Premium Efficiency Three-Phase
 Product code : 11584360
 Catalog # : 06009ST3QIE405T-W22

Performance : 400 V 50 Hz 8P IE3

Rated current : 70.9 A	Moment of inertia (J) : 40.2 sq.ft.lb
LRC : 6.7	Duty cycle : Cont.(S1)
Rated torque : 360 ft.lb	Insulation class : F
Locked rotor torque : 210 %	Service factor : 1.00
Breakdown torque : 290 %	Temperature rise : 80 K
Rated speed : 730 rpm	Design : B

Heating constant

Cooling constant

Rev.	Changes Summary	Performed	Checked	Date
Performed by			Page 20 / 36	Revision
Checked by				
Date	12/04/2022			

THERMAL LIMIT CURVE

Three Phase Induction Motor - Squirrel Cage



Customer : _____

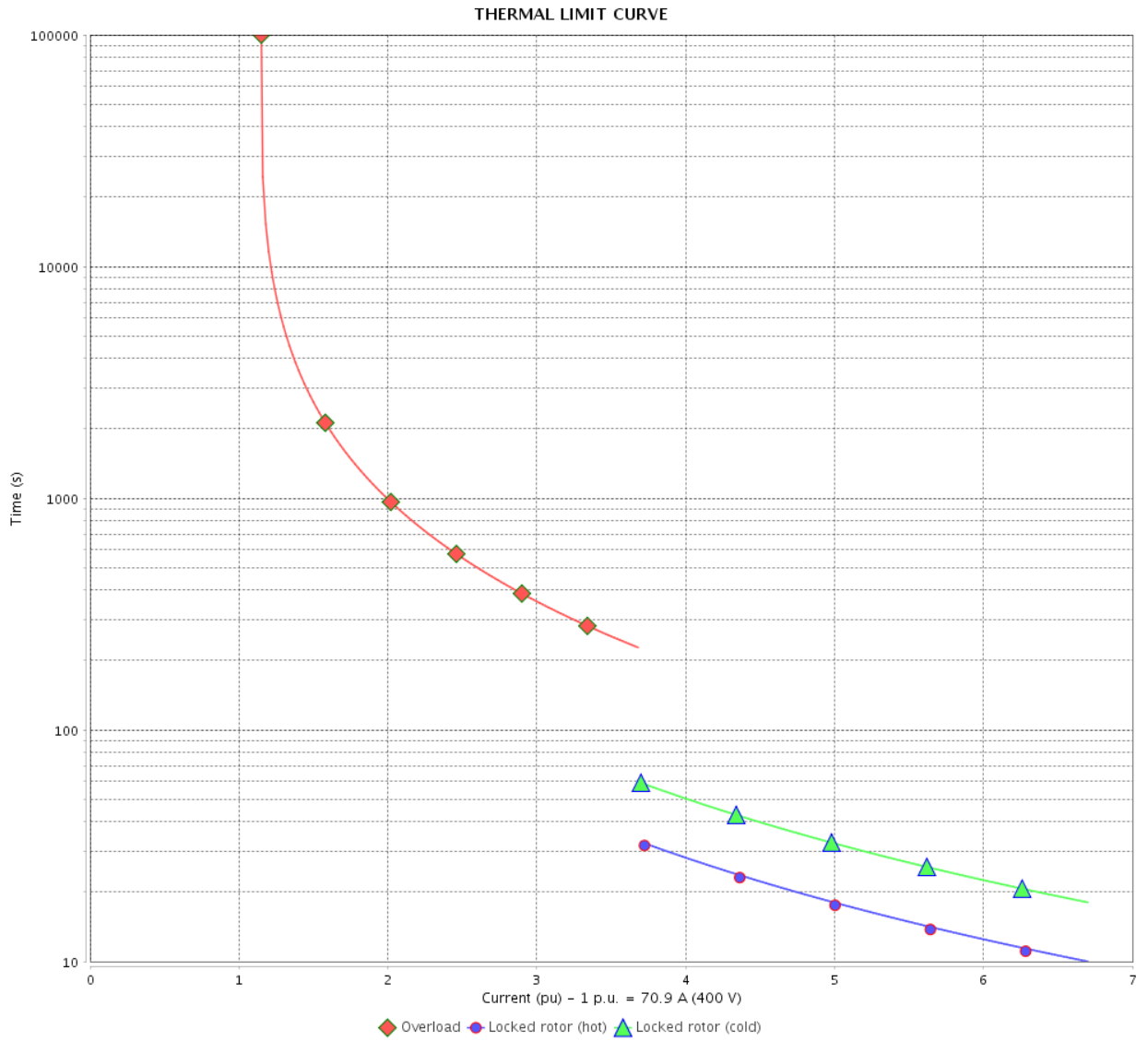

Rev.	Changes Summary	Performed	Checked	Date
Performed by		Page		Revision
Checked by		21 / 36		
Date		12/04/2022		

THERMAL LIMIT CURVE

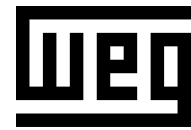

Three Phase Induction Motor - Squirrel Cage

Customer :

Product line : NEMA Premium Efficiency Three-Phase

Product code : 11584360

Catalog # : 06009ST3QIE405T-W22

Performance : 415 V 50 Hz 8P IE3

Rated current	: 69.2 A	Moment of inertia (J)	: 40.2 sq.ft.lb
LRC	: 7.3	Duty cycle	: Cont.(S1)
Rated torque	: 360 ft.lb	Insulation class	: F
Locked rotor torque	: 229 %	Service factor	: 1.00
Breakdown torque	: 310 %	Temperature rise	: 80 K
Rated speed	: 730 rpm	Design	: B

Heating constant

Cooling constant

Rev.	Changes Summary	Performed	Checked	Date
Performed by				
Checked by			Page	Revision
Date	12/04/2022		22 / 36	

THERMAL LIMIT CURVE

Three Phase Induction Motor - Squirrel Cage



Customer : _____

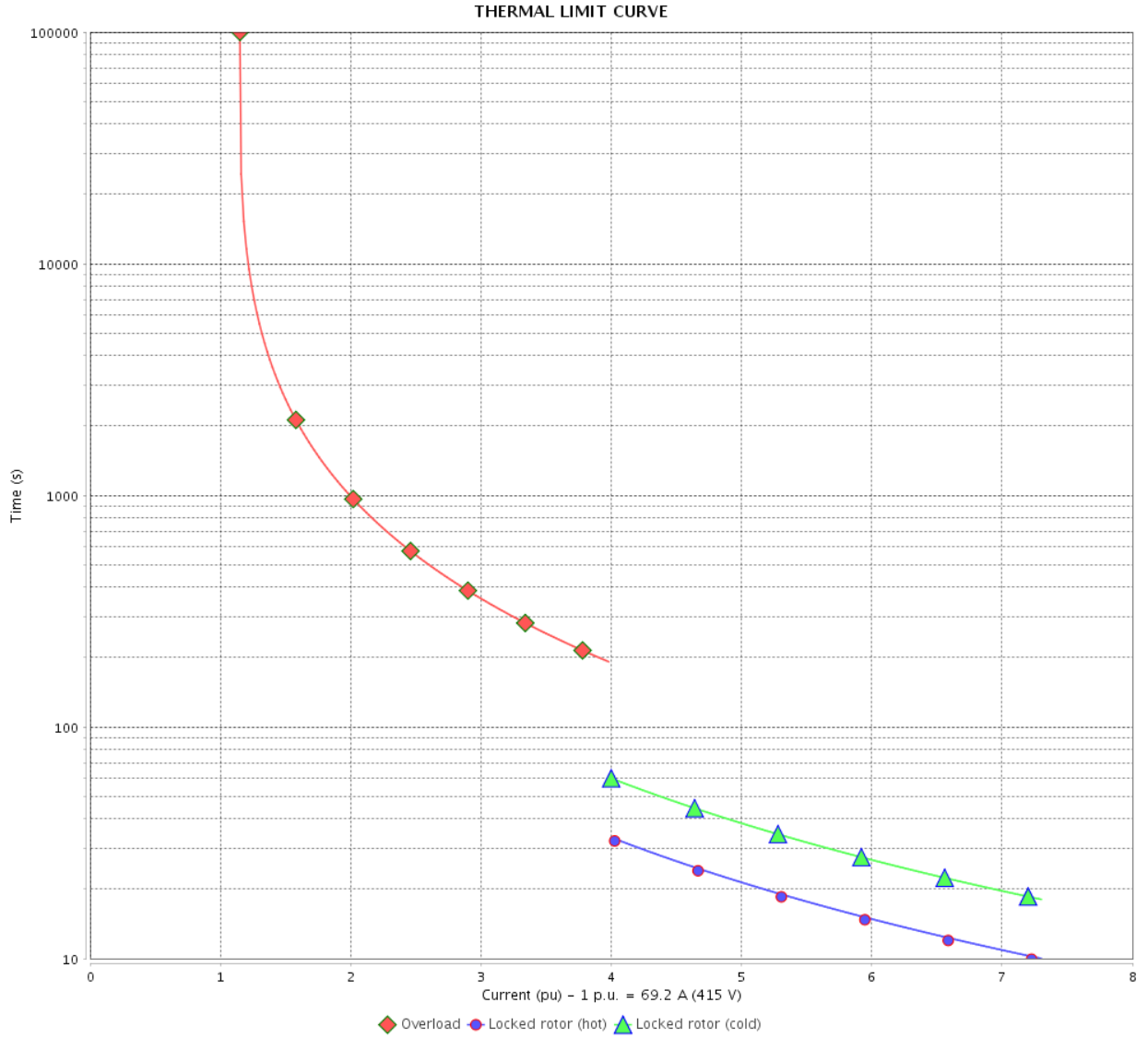

Rev.	Changes Summary	Performed	Checked	Date
Performed by		Page 23 / 36		Revision
Checked by				
Date				

THERMAL LIMIT CURVE



Three Phase Induction Motor - Squirrel Cage

Customer :

Product line : NEMA Premium Efficiency Three-Phase
Product code : 11584360
Catalog # : 06009ST3QIE405T-W22

Performance : 380 V 50 Hz 8P IE1

Rated current	: 89.2 A	Moment of inertia (J)	: 40.2 sq.ft.lb
LRC	: 5.1	Duty cycle	: Cont.(S1)
Rated torque	: 438 ft.lb	Insulation class	: F
Locked rotor torque	: 150 %	Service factor	: 1.00
Breakdown torque	: 210 %	Temperature rise	: 105 K
Rated speed	: 720 rpm	Design	: B

Heating constant

Cooling constant

Rev.	Changes Summary	Performed	Checked	Date
Performed by				
Checked by			Page	Revision
Date	12/04/2022		24 / 36	

THERMAL LIMIT CURVE

Three Phase Induction Motor - Squirrel Cage



Customer : _____

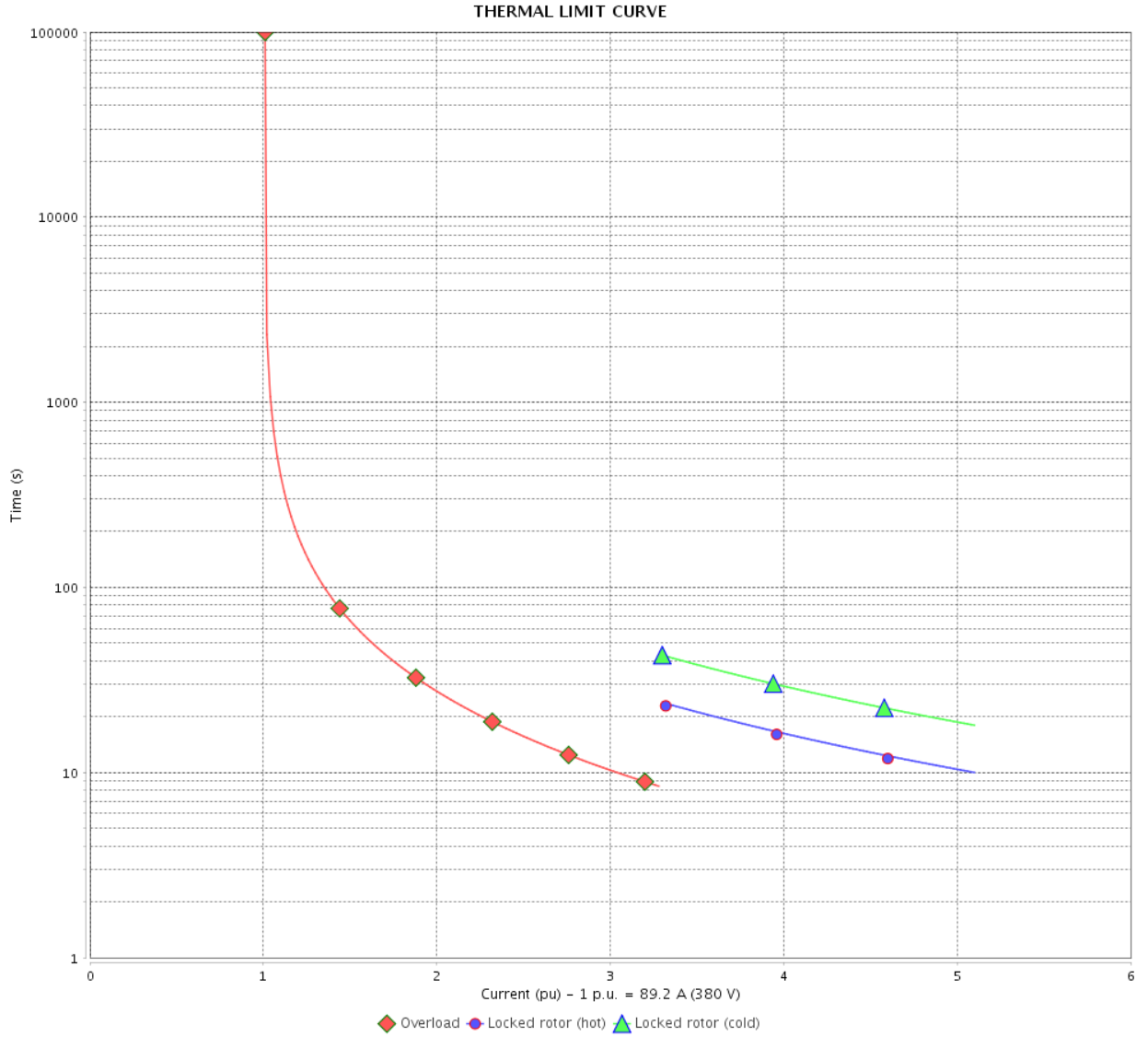

Rev.	Changes Summary	Performed	Checked	Date
Performed by		Page 25 / 36		Revision
Checked by				
Date				

THERMAL LIMIT CURVE



Three Phase Induction Motor - Squirrel Cage

Customer :

Product line : NEMA Premium Efficiency Three-Phase
Product code : 11584360
Catalog # : 06009ST3QIE405T-W22

Performance : 400 V 50 Hz 8P IE2

Rated current	: 85.0 A	Moment of inertia (J)	: 40.2 sq.ft.lb
LRC	: 5.7	Duty cycle	: Cont.(S1)
Rated torque	: 435 ft.lb	Insulation class	: F
Locked rotor torque	: 170 %	Service factor	: 1.00
Breakdown torque	: 240 %	Temperature rise	: 105 K
Rated speed	: 725 rpm	Design	: B

Heating constant

Cooling constant

Rev.	Changes Summary	Performed	Checked	Date
Performed by				
Checked by			Page	Revision
Date	12/04/2022		26 / 36	

THERMAL LIMIT CURVE

Three Phase Induction Motor - Squirrel Cage

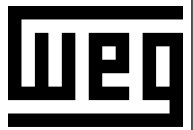

Customer : _____

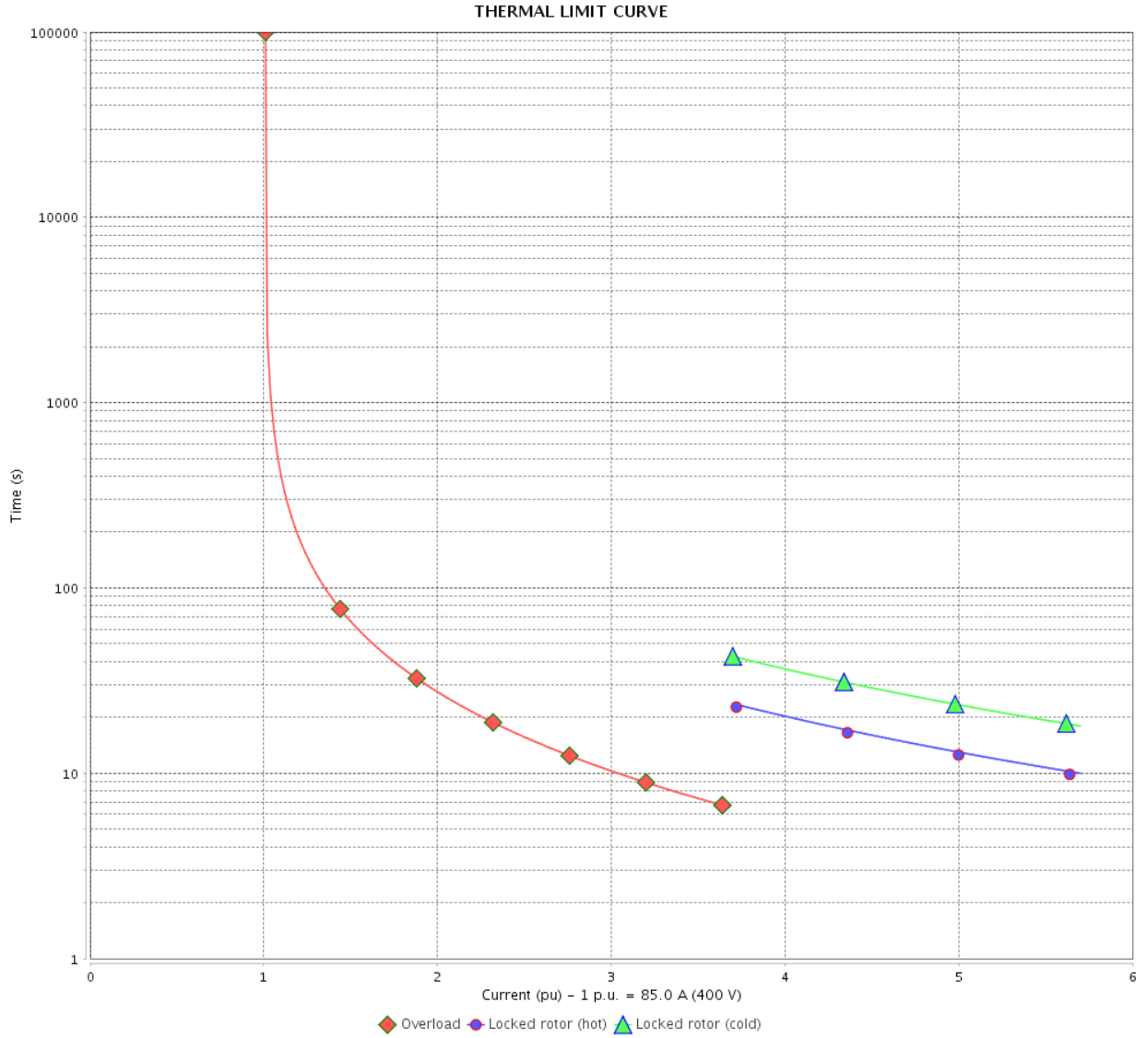

Rev.	Changes Summary	Performed	Checked	Date
Performed by		Page Revision 27 / 36		
Checked by				
Date				

THERMAL LIMIT CURVE

Three Phase Induction Motor - Squirrel Cage



Customer :

Product line : NEMA Premium Efficiency Three-Phase

Product code : 11584360

Catalog # : 06009ST3QIE405T-W22

Performance : 415 V 50 Hz 8P IE2

Rated current	: 82.9 A	Moment of inertia (J)	: 40.2 sq.ft.lb
LRC	: 6.2	Duty cycle	: Cont.(S1)
Rated torque	: 435 ft.lb	Insulation class	: F
Locked rotor torque	: 190 %	Service factor	: 1.00
Breakdown torque	: 260 %	Temperature rise	: 105 K
Rated speed	: 725 rpm	Design	: B

Heating constant

Cooling constant

Rev.	Changes Summary	Performed	Checked	Date
Performed by				
Checked by			Page	Revision
Date	12/04/2022		28 / 36	

THERMAL LIMIT CURVE

Three Phase Induction Motor - Squirrel Cage



Customer : _____

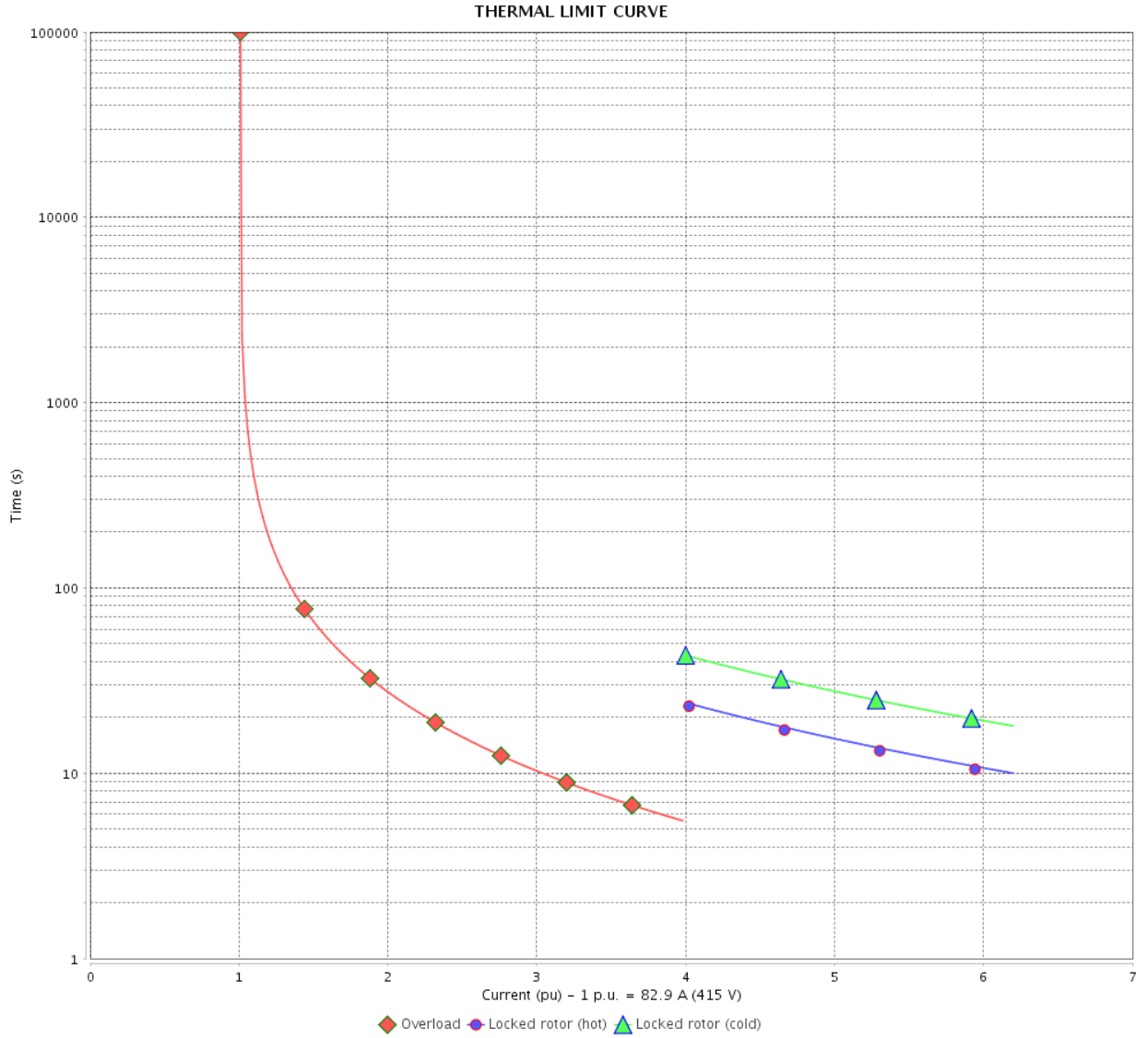

Rev.	Changes Summary	Performed	Checked	Date
Performed by		Page		Revision
Checked by		29 / 36		
Date		12/04/2022		

VFD OPERATION CURVE

Three Phase Induction Motor - Squirrel Cage



Customer :

Product line : NEMA Premium Efficiency Three-Phase

Product code : 11584360

Catalog # : 06009ST3QIE405T-W22

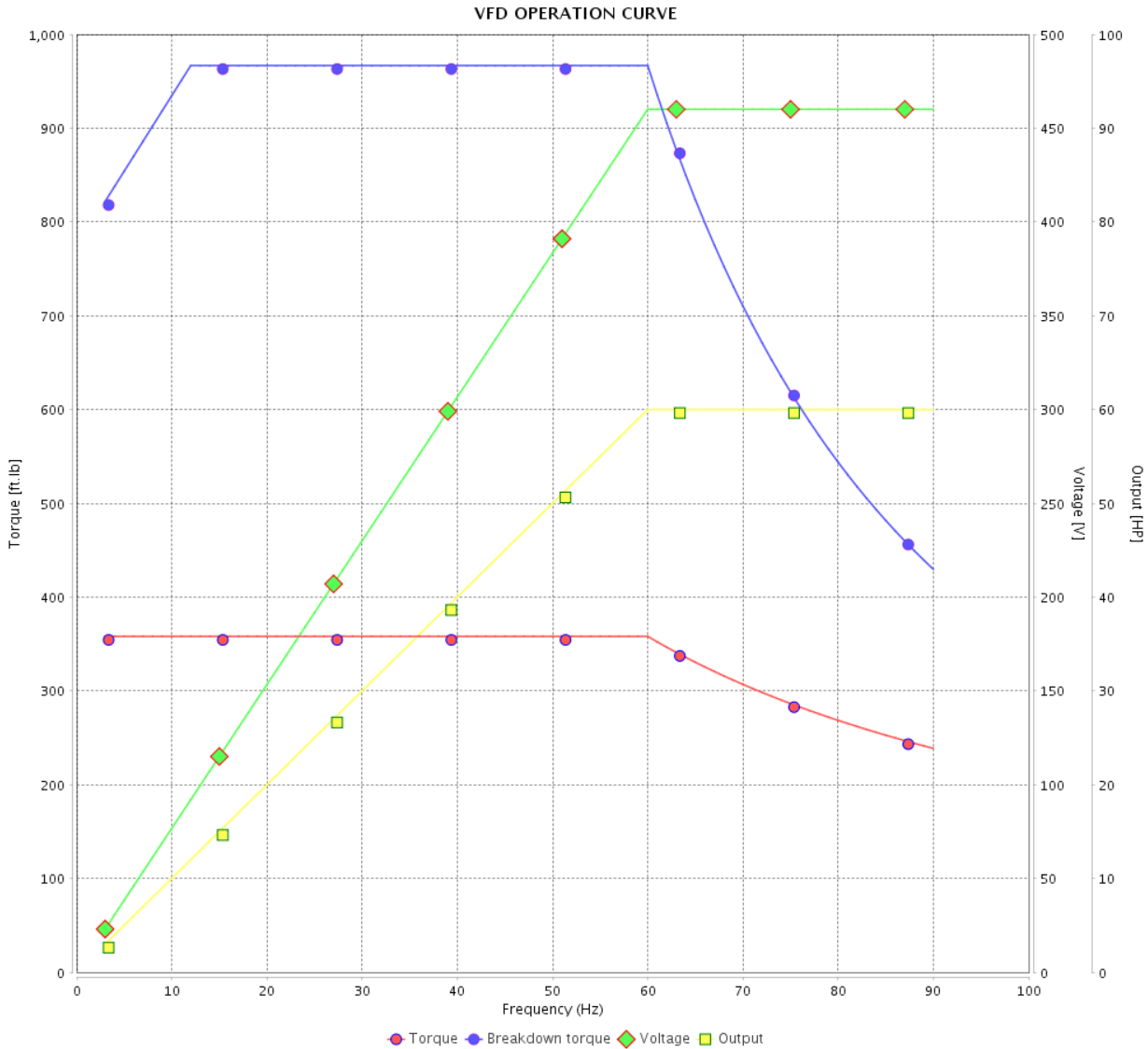

Performance : 460 V 60 Hz 8P

Rated current : 73.0 A
 LRC : 6.5
 Rated torque : 358 ft.lb
 Locked rotor torque : 180 %
 Breakdown torque : 270 %
 Rated speed : 880 rpm

Moment of inertia (J) : 40.2 sq.ft.lb
 Duty cycle : Cont.(S1)
 Insulation class : F
 Service factor : 1.25
 Temperature rise : 80 K
 Design : B

Rev.	Changes Summary	Performed	Checked	Date
Performed by			Page 30 / 36	Revision
Checked by				
Date	12/04/2022			

VFD OPERATION CURVE

Three Phase Induction Motor - Squirrel Cage



Customer : _____

Product line : NEMA Premium Efficiency Three-Phase

Product code : 11584360

Catalog # : 06009ST3QIE405T-W22

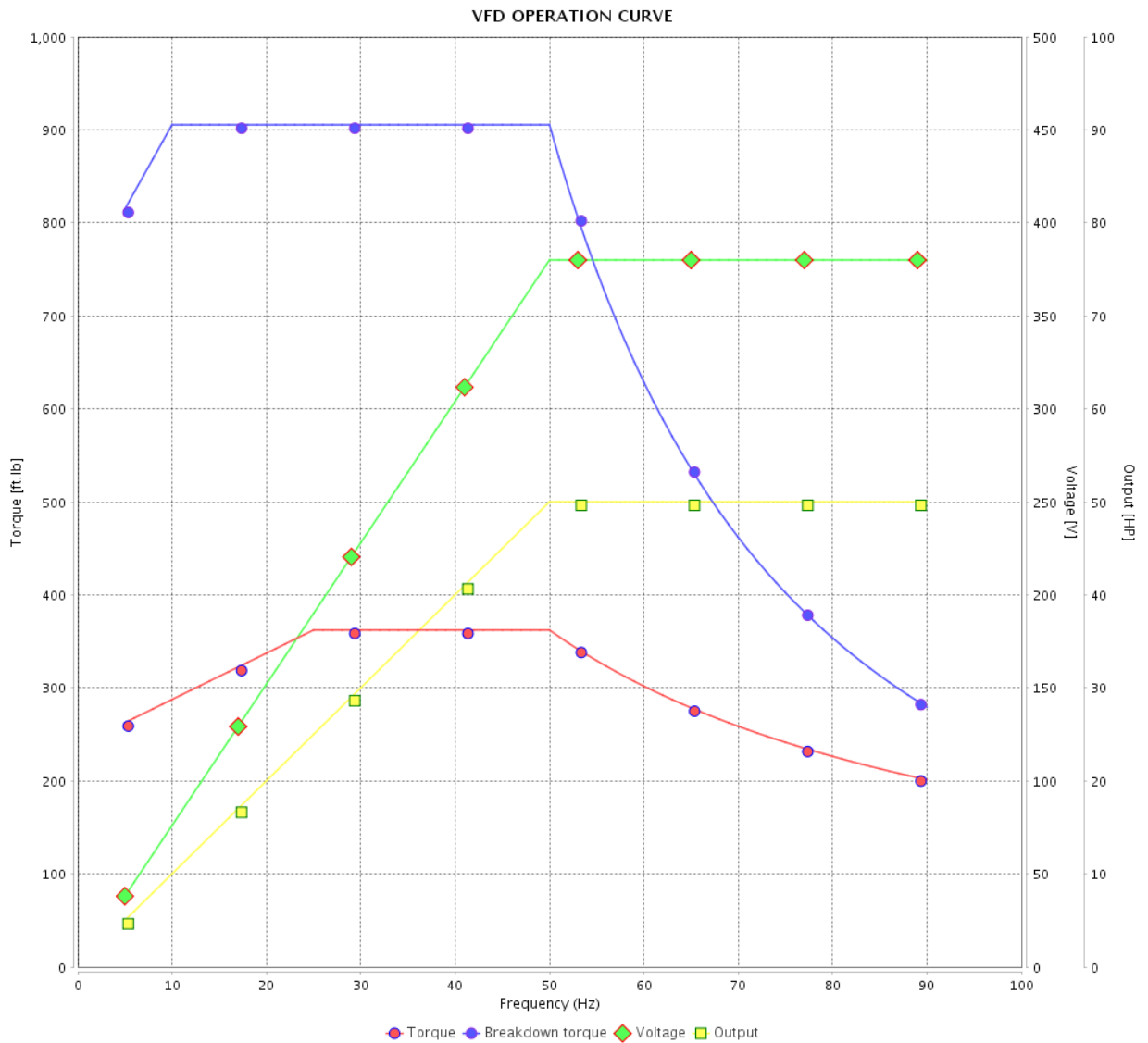

Performance : 380 V 50 Hz 8P IE3

Rated current : 72.9 A
 LRC : 6.1
 Rated torque : 362 ft.lb
 Locked rotor torque : 180 %
 Breakdown torque : 250 %
 Rated speed : 725 rpm

Moment of inertia (J) : 40.2 sq.ft.lb
 Duty cycle : Cont.(S1)
 Insulation class : F
 Service factor : 1.00
 Temperature rise : 80 K
 Design : B

Rev.	Changes Summary	Performed	Checked	Date
Performed by			Page 31 / 36	Revision
Checked by				
Date	12/04/2022			

VFD OPERATION CURVE

Three Phase Induction Motor - Squirrel Cage



Customer :

Product line : NEMA Premium Efficiency Three-Phase

Product code : 11584360

Catalog # : 06009ST3QIE405T-W22

VFD OPERATION CURVE

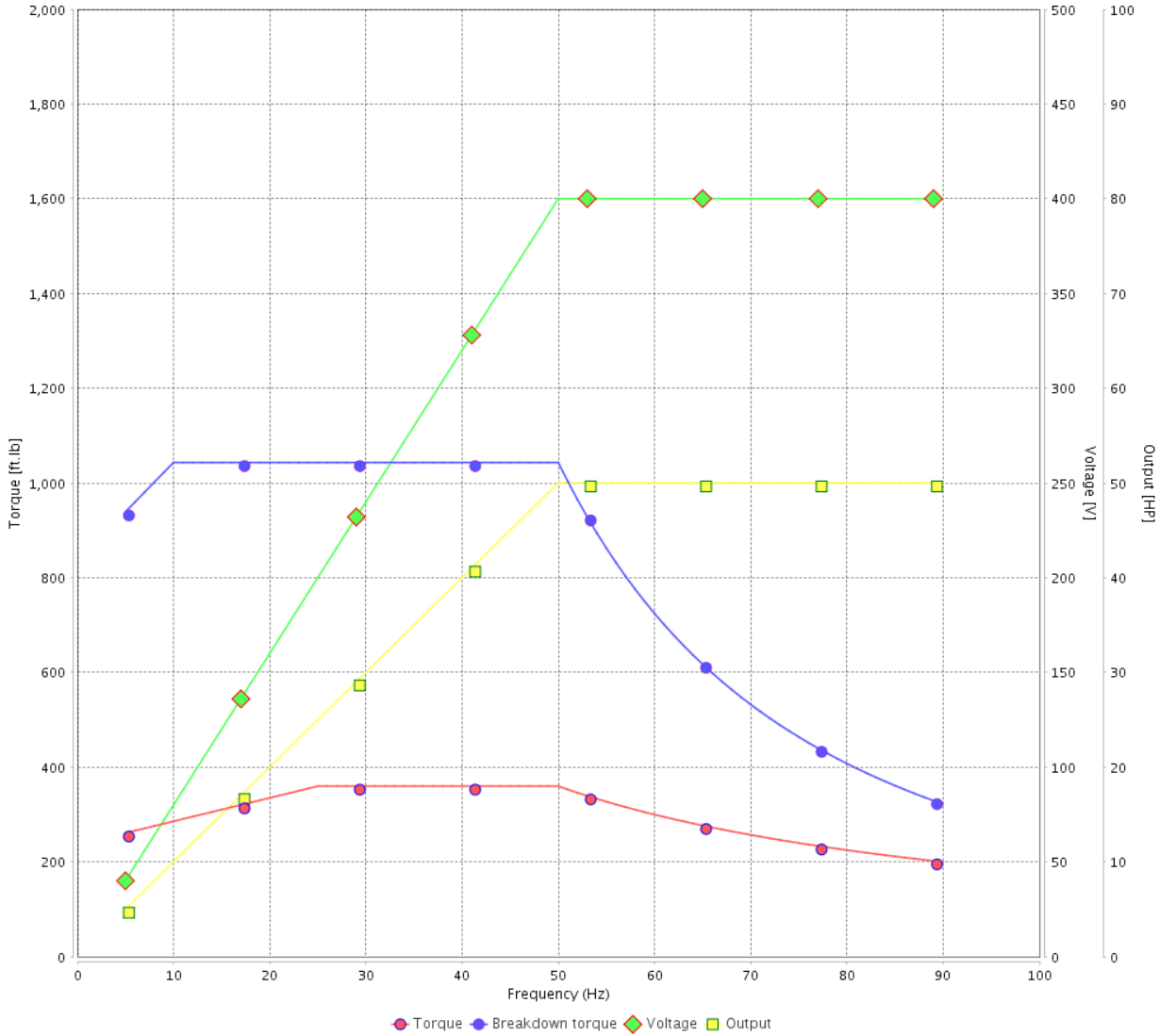

Performance : 400 V 50 Hz 8P IE3

Rated current : 70.9 A
 LRC : 6.7
 Rated torque : 360 ft.lb
 Locked rotor torque : 210 %
 Breakdown torque : 290 %
 Rated speed : 730 rpm

Moment of inertia (J) : 40.2 sq.ft.lb
 Duty cycle : Cont.(S1)
 Insulation class : F
 Service factor : 1.00
 Temperature rise : 80 K
 Design : B

Rev.	Changes Summary	Performed	Checked	Date
Performed by			Page	Revision
Checked by				
Date				

VFD OPERATION CURVE

Three Phase Induction Motor - Squirrel Cage



Customer : _____

Product line : NEMA Premium Efficiency Three-Phase

Product code : 11584360

Catalog # : 06009ST3QIE405T-W22

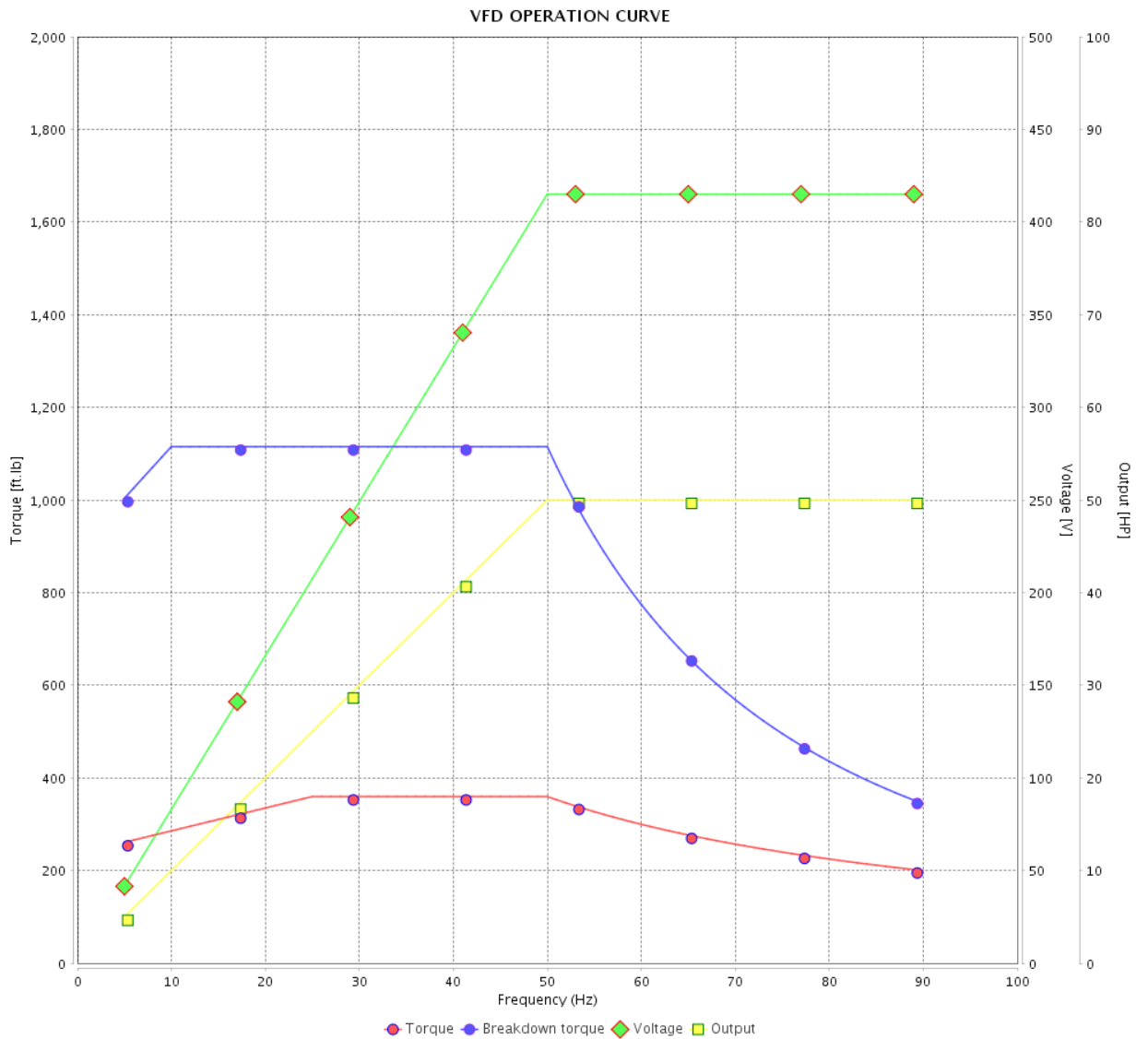

Performance : 415 V 50 Hz 8P IE3

Rated current : 69.2 A
 LRC : 7.3
 Rated torque : 360 ft.lb
 Locked rotor torque : 229 %
 Breakdown torque : 310 %
 Rated speed : 730 rpm

Moment of inertia (J) : 40.2 sq.ft.lb
 Duty cycle : Cont.(S1)
 Insulation class : F
 Service factor : 1.00
 Temperature rise : 80 K
 Design : B

Rev.	Changes Summary	Performed	Checked	Date
Performed by		Page		Revision
Checked by		33 / 36		
Date	12/04/2022			

VFD OPERATION CURVE

Three Phase Induction Motor - Squirrel Cage



Customer :

Product line : NEMA Premium Efficiency Three-Phase

Product code : 11584360

Catalog # : 06009ST3QIE405T-W22

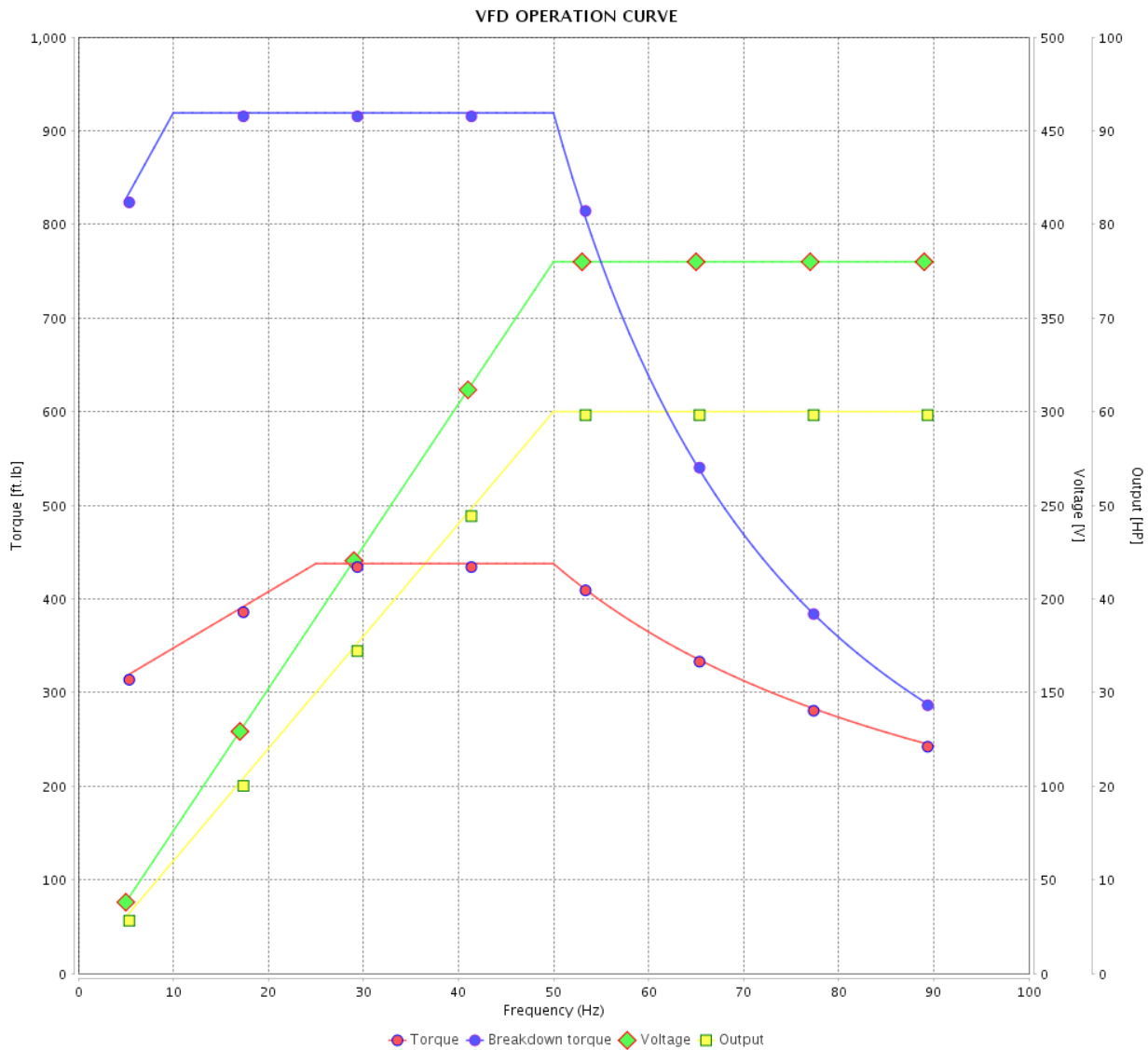

Performance : 380 V 50 Hz 8P IE1

Rated current	: 89.2 A	Moment of inertia (J)	: 40.2 sq.ft.lb
LRC	: 5.1	Duty cycle	: Cont.(S1)
Rated torque	: 438 ft.lb	Insulation class	: F
Locked rotor torque	: 150 %	Service factor	: 1.00
Breakdown torque	: 210 %	Temperature rise	: 105 K
Rated speed	: 720 rpm	Design	: B

Rev.	Changes Summary	Performed	Checked	Date
Performed by		Page		Revision
Checked by		34 / 36		
Date	12/04/2022			

VFD OPERATION CURVE

Three Phase Induction Motor - Squirrel Cage



Customer :

Product line : NEMA Premium Efficiency Three-Phase

Product code : 11584360

Catalog # : 06009ST3QIE405T-W22

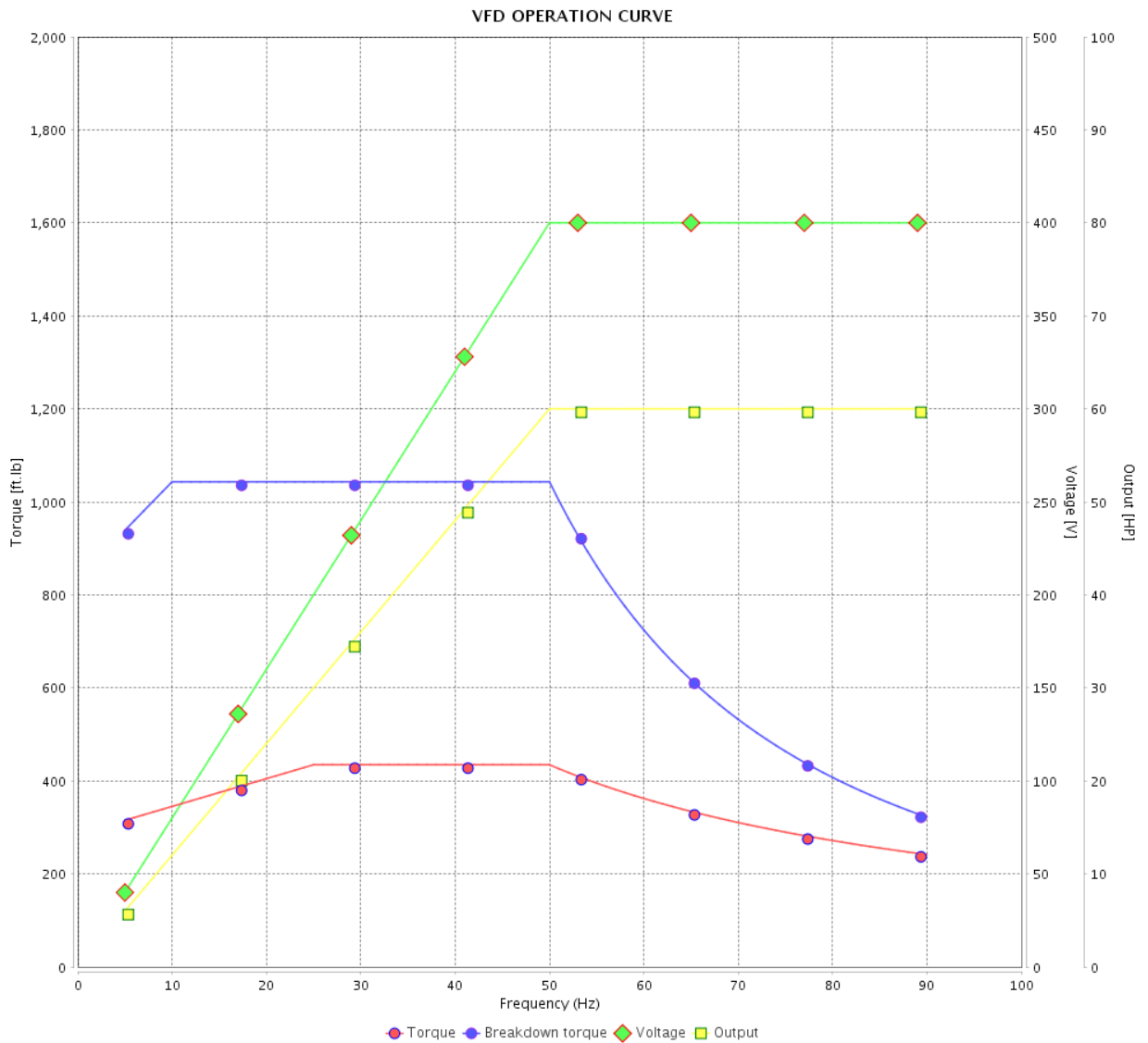

Performance : 400 V 50 Hz 8P IE2

Rated current : 85.0 A
 LRC : 5.7
 Rated torque : 435 ft.lb
 Locked rotor torque : 170 %
 Breakdown torque : 240 %
 Rated speed : 725 rpm

Moment of inertia (J) : 40.2 sq.ft.lb
 Duty cycle : Cont.(S1)
 Insulation class : F
 Service factor : 1.00
 Temperature rise : 105 K
 Design : B

Rev.	Changes Summary	Performed	Checked	Date
Performed by			Page 35 / 36	Revision
Checked by				
Date	12/04/2022			

VFD OPERATION CURVE

Three Phase Induction Motor - Squirrel Cage



Customer :

Product line : NEMA Premium Efficiency Three-Phase

Product code : 11584360

Catalog # : 06009ST3QIE405T-W22

VFD OPERATION CURVE

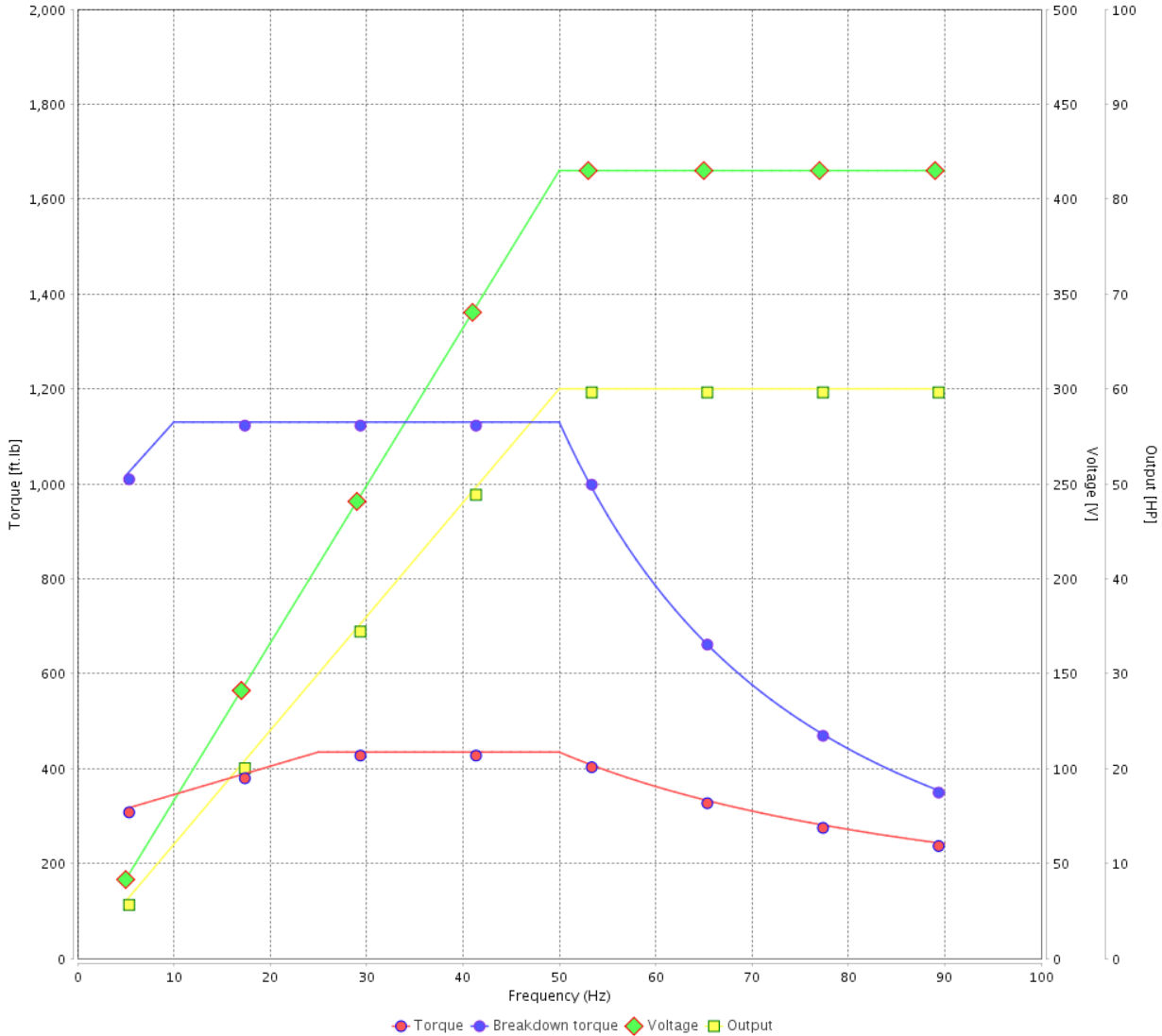

Performance : 415 V 50 Hz 8P IE2

Rated current	: 82.9 A	Moment of inertia (J)	: 40.2 sq.ft.lb
LRC	: 6.2	Duty cycle	: Cont.(S1)
Rated torque	: 435 ft.lb	Insulation class	: F
Locked rotor torque	: 190 %	Service factor	: 1.00
Breakdown torque	: 260 %	Temperature rise	: 105 K
Rated speed	: 725 rpm	Design	: B

Rev.	Changes Summary	Performed	Checked	Date
Performed by			Page 36 / 36	Revision
Checked by				
Date	12/04/2022			

1 2 3 4 5 6

A

B

C

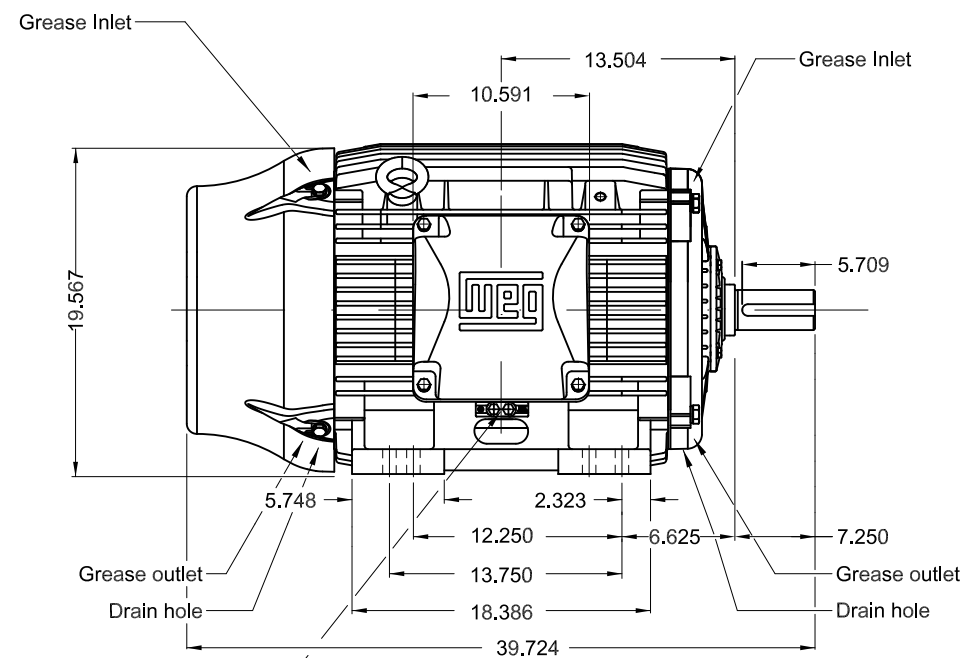
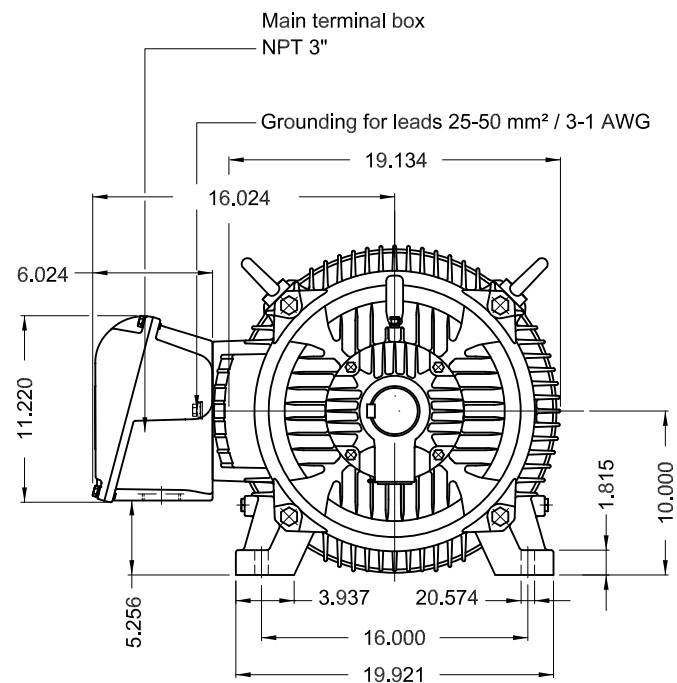

Grounding for leads 25-185 mm² / 3AWG-350MCM

D

E

60 HP 08 Poles 60 Hz A

Color RAL 5009
Painting plan 202E
Mounting B3R(D)

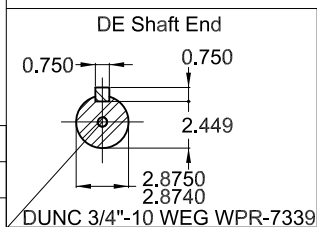

ECM	LOC	SUMMARY OF MODIFICATIONS	EXECUTED	CHECKED	RELEASED	DATE	VER
EXECUTED	PIRWBUSER	THREE PH. MOTOR IEEE 841 W22 PREM. EFF.					
CHECKED		FRAME 404/5T IP55 TEFC					
RELEASED							
REL DT.	WMO	Jaragua do Sul	Product Engineering	SHEET	1 / 1		

PREVIEW
WDD





NEMA
Premium
W22



FOR SAFE AREA
Mod.TE1BFOXON
CC029A



Class I, Div 2, Gr A, B, C and D - T3
Class I, Zone 2, IIC - T3
Class II, Div 2, Gr F and G - T4
For use on PWM: Gr. A, B, C, D and F,
VT 1000:1, CT 20:1, 1.00SF - T3A

MODEL 06009ST3QIE405T-W22



Inverter Duty Motor
Severe Duty

MADE IN BRAZIL
11584360

PH3 60Hz Fr. 404/5T 1000m.a.s.l. IP55 TEFC 1157lb

V 460

A 73.0

HP 60

kW 45

SF 1.25

SFA 91.3

RPM 880

PF 0.83

AMB 40°C

INS cl. F DT80K

NEMA NOM EFF 93.0%

DUTY CONT.

DES B Code H

GUARANT. EFF 91.7%

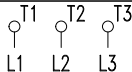

460V



→ 6316-C3 (34g) 80BC03X30

→ 6314-C3 (27g) 70BC03X30



MOBIL POLYREX EM (20000h)

