

DATA SHEET



Three Phase Induction Motor - Squirrel Cage

Customer :																			
Product line	: NEMA Premium Efficiency Three-Phase																		
Product code :	13500517																		
Catalog # :	10009ET3GKD445T-W22																		
Frame : 444/5T Output : 100 HP (75 kW) Poles : 8 Frequency : 60 Hz Rated voltage : 460 V Rated current : 130 A L. R. Amperes : 793 A LRC : 6.1x(Code H) No load current : 60.0 A Rated speed : 890 rpm Slip : 1.11 % Rated torque : 590 ft.lb Locked rotor torque : 210 % Breakdown torque : 220 % Insulation class : F Service factor : 1.25 Moment of inertia (J) : 87.3 sq.ft.lb Design : A	Locked rotor time : 27s (cold) 15s (hot) Temperature rise : 80 K Duty cycle : Cont.(S1) Ambient temperature : -20°C to +40°C Altitude : 1000 m.a.s.l. Protection degree : IP55 Cooling method : IC411 - TEFC Mounting : F-1 Rotation ¹ : Both (CW and CCW) Noise level ² : 63.0 dB(A) Starting method : Direct On Line Approx. weight ³ : 1784 lb																		
Output	25% 50% 75% 100%																		
Efficiency (%)	0.000 93.6 94.1 94.1																		
Power Factor	0.00 0.62 0.72 0.77																		
Foundation loads																			
Max. traction	: 2568 lb																		
Max. compression	: 4352 lb																		
	<table border="0"> <tr> <td></td> <td style="text-align: center;"><u>Drive end</u></td> <td style="text-align: center;"><u>Non drive end</u></td> </tr> <tr> <td>Bearing type</td> <td>: NU-319 C3</td> <td>6316 C3</td> </tr> <tr> <td>Sealing</td> <td>: WSeal</td> <td>WSeal</td> </tr> <tr> <td>Lubrication interval</td> <td>: 15000 h</td> <td>20000 h</td> </tr> <tr> <td>Lubricant amount</td> <td>: 45 g</td> <td>34 g</td> </tr> <tr> <td>Lubricant type</td> <td colspan="2" style="text-align: center;">Mobil Polyrex EM</td> </tr> </table>		<u>Drive end</u>	<u>Non drive end</u>	Bearing type	: NU-319 C3	6316 C3	Sealing	: WSeal	WSeal	Lubrication interval	: 15000 h	20000 h	Lubricant amount	: 45 g	34 g	Lubricant type	Mobil Polyrex EM	
	<u>Drive end</u>	<u>Non drive end</u>																	
Bearing type	: NU-319 C3	6316 C3																	
Sealing	: WSeal	WSeal																	
Lubrication interval	: 15000 h	20000 h																	
Lubricant amount	: 45 g	34 g																	
Lubricant type	Mobil Polyrex EM																		
Notes																			
This revision replaces and cancel the previous one, which must be eliminated. (1) Looking the motor from the shaft end. (2) Measured at 1m and with tolerance of +3dB(A). (3) Approximate weight subject to changes after manufacturing process. (4) At 100% of full load.																			
These are average values based on tests with sinusoidal power supply, subject to the tolerances stipulated in NEMA MG-1.																			
Rev.	Changes Summary	Performed	Checked	Date															
Performed by																			
Checked by			Page	Revision															
Date	12/04/2022		1 / 6																

TORQUE AND CURRENT VS SPEED CURVE

Three Phase Induction Motor - Squirrel Cage



Customer :

Product line : NEMA Premium Efficiency Three-Phase

Product code : 13500517

Catalog # : 10009ET3GKD445T-W22

TORQUE AND CURRENT VS SPEED CURVE

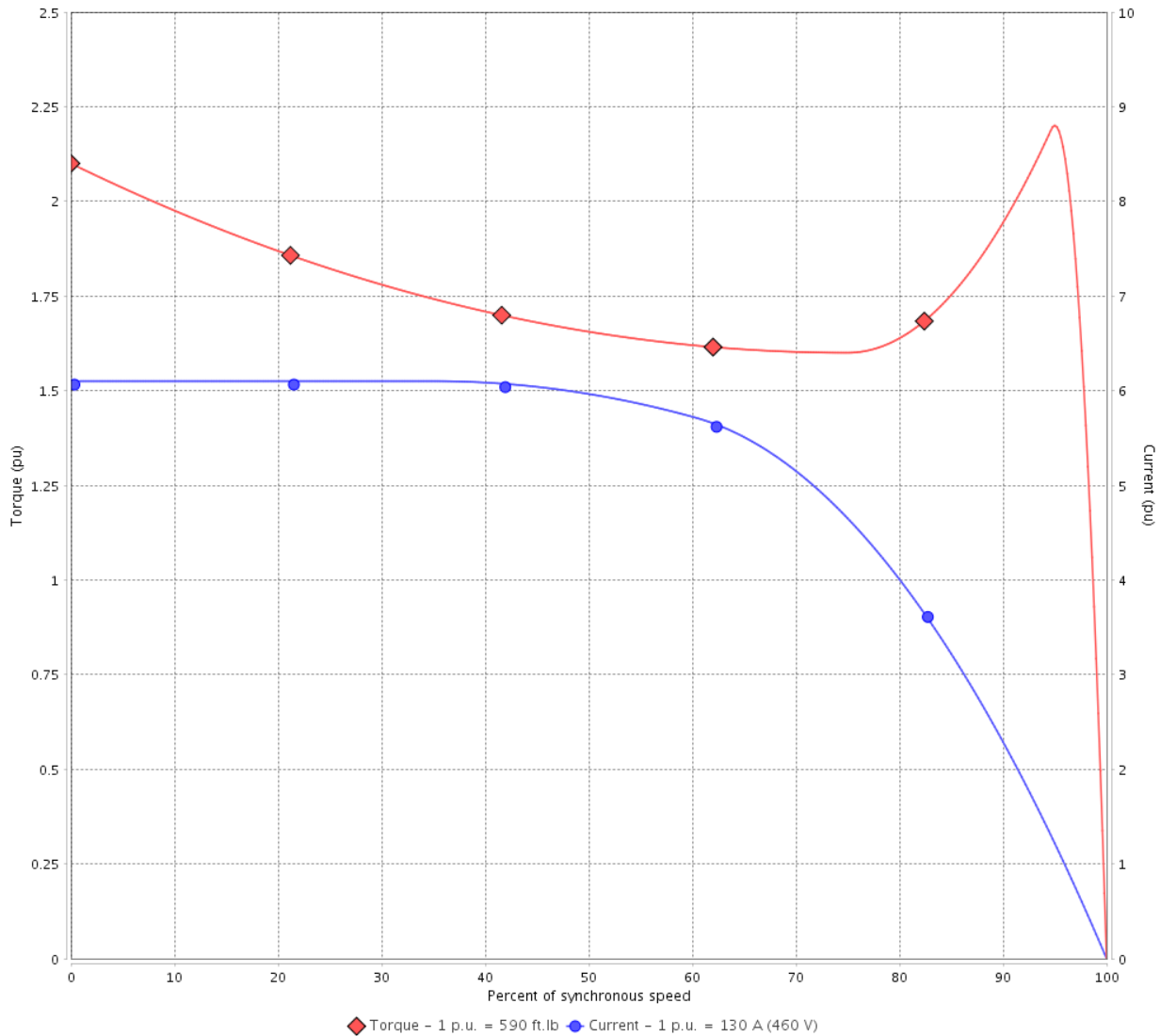

Performance : 460 V 60 Hz 8P

Rated current	: 130 A	Moment of inertia (J)	: 87.3 sq.ft.lb
LRC	: 6.1	Duty cycle	: Cont.(S1)
Rated torque	: 590 ft.lb	Insulation class	: F
Locked rotor torque	: 210 %	Service factor	: 1.25
Breakdown torque	: 220 %	Temperature rise	: 80 K
Rated speed	: 890 rpm	Design	: A

Locked rotor time : 27s (cold) 15s (hot)

Rev.	Changes Summary	Performed	Checked	Date
Performed by			Page 2 / 6	Revision
Checked by				
Date	12/04/2022			

LOAD PERFORMANCE CURVE

Three Phase Induction Motor - Squirrel Cage



Customer :

Product line : NEMA Premium Efficiency Three-Phase

Product code : 13500517

Catalog # : 10009ET3GKD445T-W22

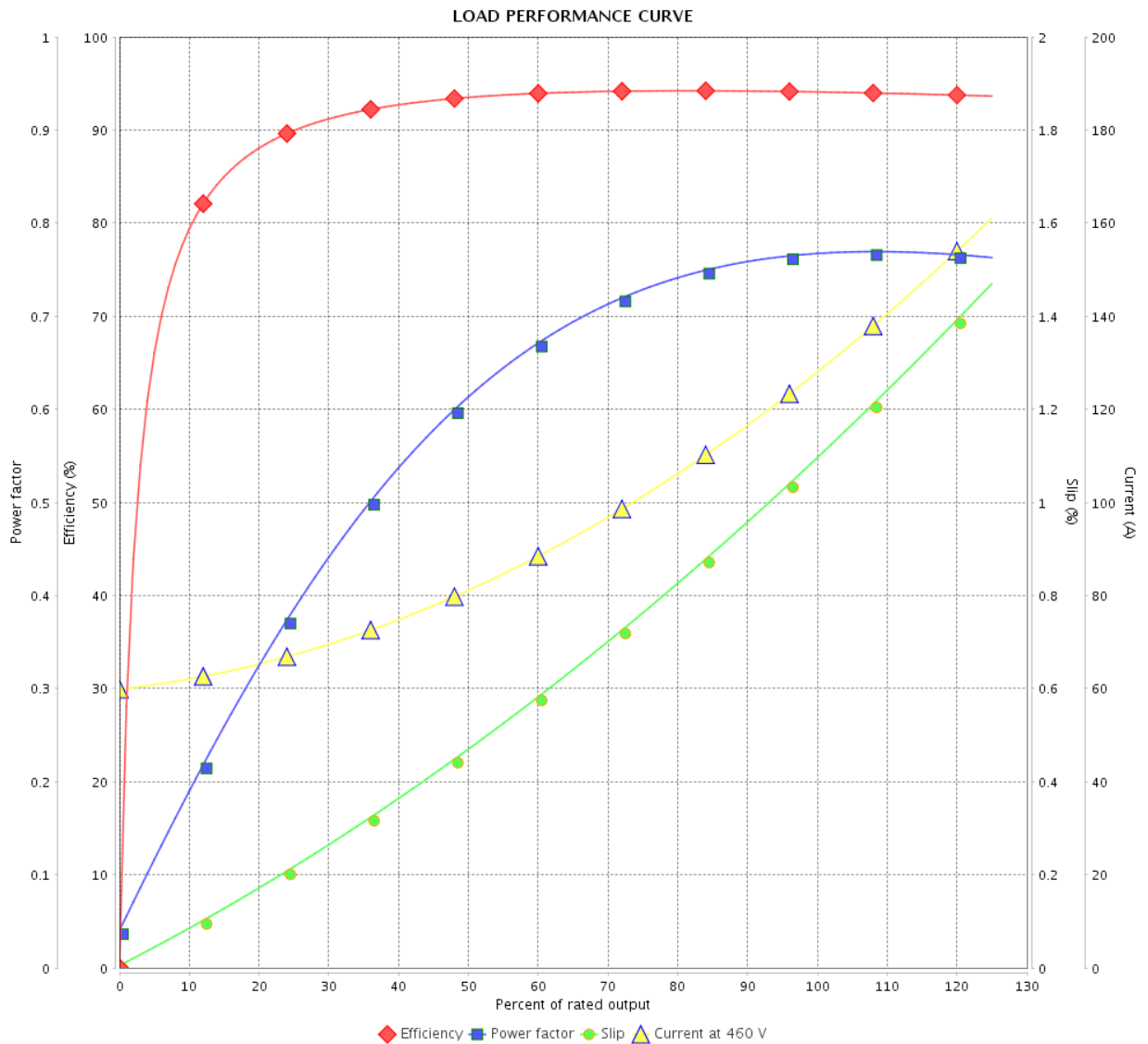

Performance : 460 V 60 Hz 8P

Rated current : 130 A
 LRC : 6.1
 Rated torque : 590 ft.lb
 Locked rotor torque : 210 %
 Breakdown torque : 220 %
 Rated speed : 890 rpm

Moment of inertia (J) : 87.3 sq.ft.lb
 Duty cycle : Cont.(S1)
 Insulation class : F
 Service factor : 1.25
 Temperature rise : 80 K
 Design : A

Rev.	Changes Summary	Performed	Checked	Date
Performed by		Page		Revision
Checked by		3 / 6		
Date		12/04/2022		

THERMAL LIMIT CURVE

Three Phase Induction Motor - Squirrel Cage



Customer :

Product line : NEMA Premium Efficiency Three-Phase
Product code : 13500517
Catalog # : 10009ET3GKD445T-W22

Performance : 460 V 60 Hz 8P

Rated current	: 130 A	Moment of inertia (J)	: 87.3 sq.ft.lb
LRC	: 6.1	Duty cycle	: Cont.(S1)
Rated torque	: 590 ft.lb	Insulation class	: F
Locked rotor torque	: 210 %	Service factor	: 1.25
Breakdown torque	: 220 %	Temperature rise	: 80 K
Rated speed	: 890 rpm	Design	: A

Heating constant

Cooling constant

Rev.	Changes Summary	Performed	Checked	Date
Performed by				
Checked by			Page	Revision
Date	12/04/2022		4 / 6	

THERMAL LIMIT CURVE

Three Phase Induction Motor - Squirrel Cage



Customer : _____

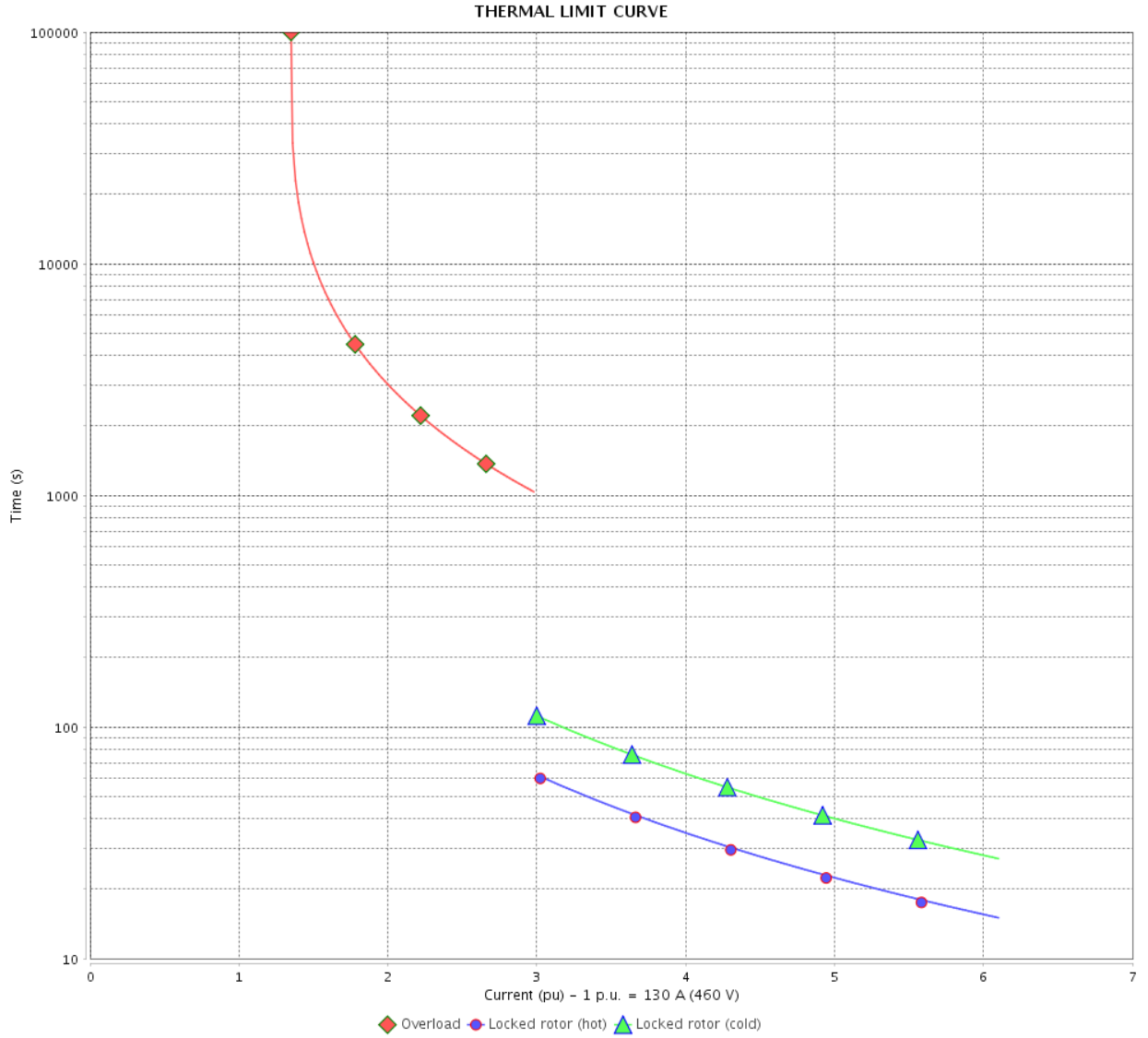

Rev.	Changes Summary	Performed	Checked	Date
Performed by		Page 5 / 6		Revision
Checked by				
Date				

VFD OPERATION CURVE

Three Phase Induction Motor - Squirrel Cage



Customer :

Product line : NEMA Premium Efficiency Three-Phase

Product code : 13500517

Catalog # : 10009ET3GKD445T-W22

VFD OPERATION CURVE

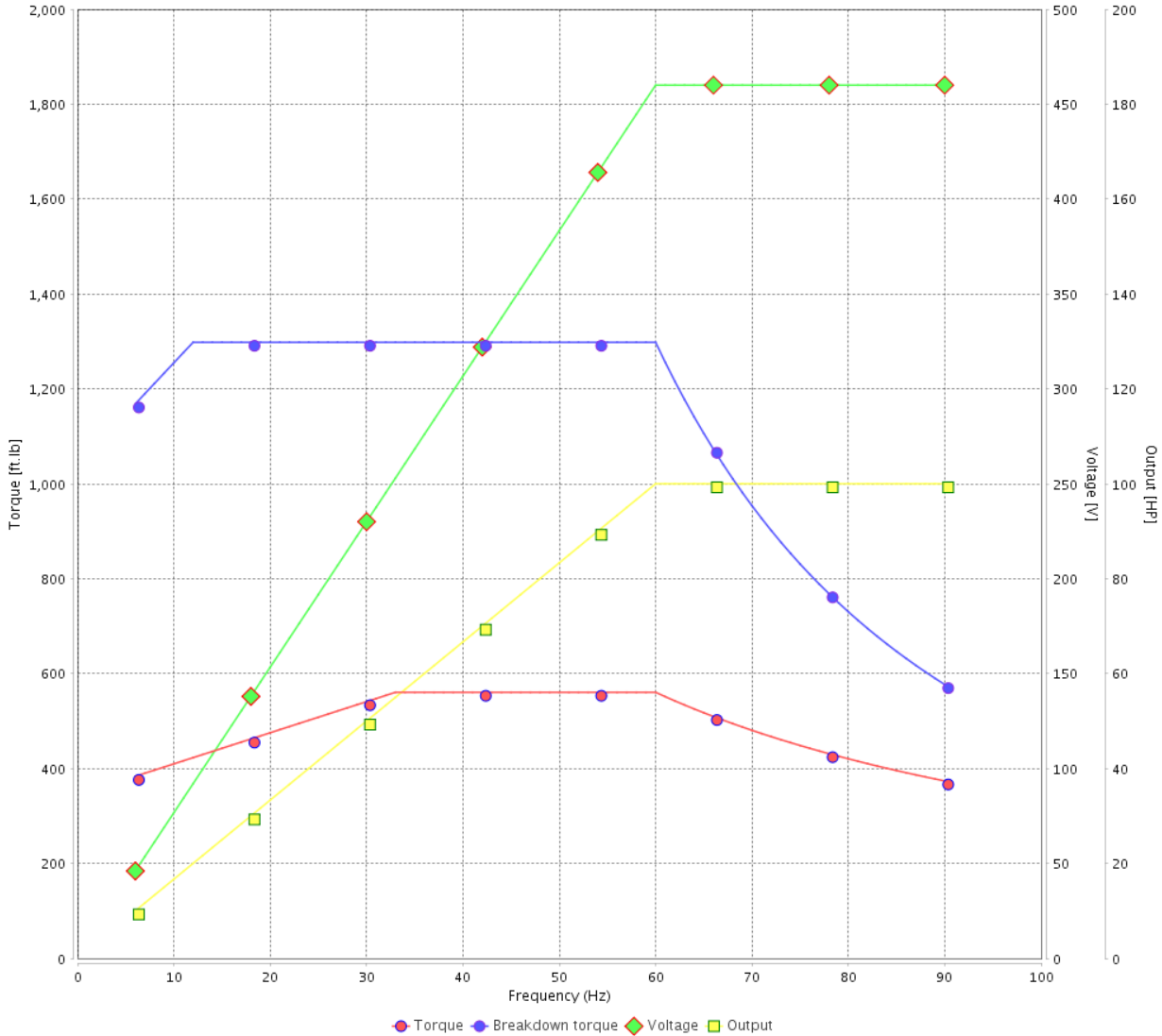

Performance : 460 V 60 Hz 8P

Rated current : 130 A
 LRC : 6.1
 Rated torque : 590 ft.lb
 Locked rotor torque : 210 %
 Breakdown torque : 220 %
 Rated speed : 890 rpm

Moment of inertia (J) : 87.3 sq.ft.lb
 Duty cycle : Cont.(S1)
 Insulation class : F
 Service factor : 1.25
 Temperature rise : 80 K
 Design : A

Rev.	Changes Summary	Performed	Checked	Date
Performed by			Page 6 / 6	Revision
Checked by				
Date	12/04/2022			

1 2 3 4 5 6

A

B

C

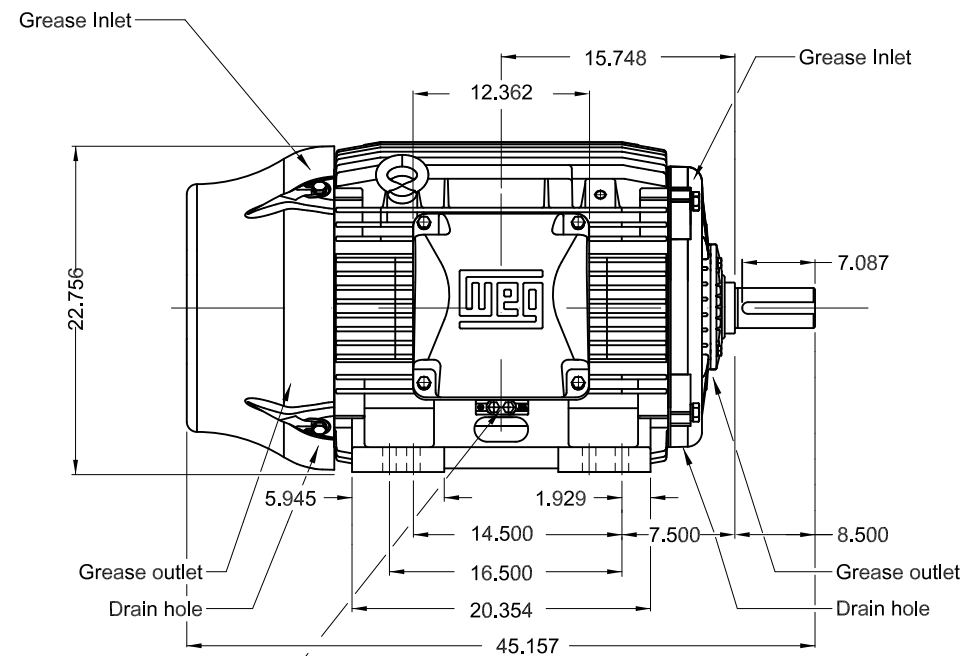
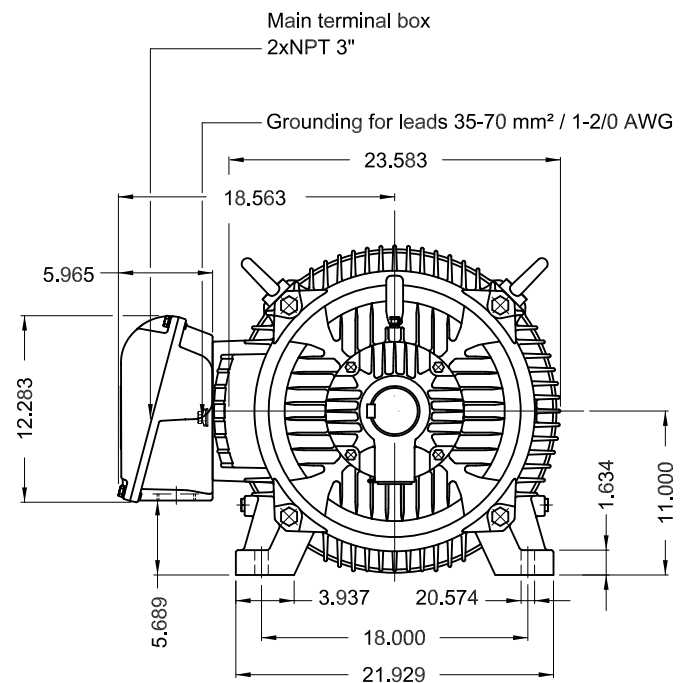

D

E

Design A
DE roller bearing
Shaft locking device
Color RAL 5009
Painting plan 203A
Mounting NEMA F-1
Mounting B3R(D)

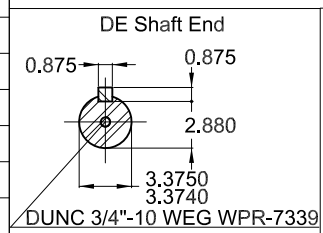

100 HP 08 Poles 60 Hz A

ECM	LOC	SUMMARY OF MODIFICATIONS	EXECUTED	CHECKED	RELEASED	DATE	VER
EXECUTED	PIRWUSER	THREE PH. MOTOR W22 PREM. EFF.					
CHECKED		FRAME 444/5T IP55 TEFC					
RELEASED							
REL DT.	WMO	Jaragua do Sul	Product Engineering	SHEET	1 / 1		

PREVIEW
WDD



MADE IN BRAZIL
13500517



NEMA
Premium
W22



FOR SAFE AREA
Mod.TE1BFOXON
CC029A



Class I, Div 2, Gr A, B, C and D - T3
Class I, Zone 2, IIC - T3
Class II, Div 2, Gr F and G - T3C
For use on PWM: Gr. A, B, C, D and F,
VT 1000:1, CT 20:1, 1.00SF - T3A

MODEL 10009ET3GKD445T-W22

Inverter Duty Motor
Severe Duty

PH3 60Hz Fr. 444/5T 1000m.a.s.l. IP55 TEFC 1768lb

V 460

A 130

HP 100

kW 75

SF 1.25

SFA 163

RPM 890

PF 0.77

AMB 40°C

INS cl. F DT80K

NEMA NOM EFF 94.1%

DUTY CONT.

DES A Code H

PART-WINDING

WYE-DELTA

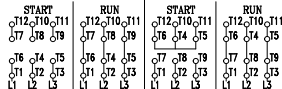

→ NU-319-C3 (45g)

→ 6316-C3 (34g)



MOBIL POLYREX EM (15000h)

