

DATA SHEET

Three Phase Induction Motor - Squirrel Cage



Customer :						
Product line		: W40 NEMA Premium Efficiency Three-Phase	Product code :	14026894		
			Catalog # :	20036OT3G444TS-W40		
Frame		: 444/5TS	Cooling method : IC01 - ODP			
Insulation class		: F	Mounting : F-1			
Duty cycle		: Cont.(S1)	Rotation ¹ : Both (CW and CCW)			
Ambient temperature		: -20°C to +40°C	Starting method : Direct On Line			
Altitude		: 1000 m.a.s.l.	Approx. weight ² : 1267 lb			
Protection degree		: IP23	Moment of inertia (J) : 23.8 sq.ft.lb			
Design		: B				
Output [HP]	200	175	175	175		
Poles	2	2	2	2		
Frequency [Hz]	60	50	50	50		
Rated voltage [V]	460	380	400	415		
Rated current [A]	225	239	230	224		
L. R. Amperes [A]	1463	1530	1633	1658		
LRC [A]	6.5x(Code G)	6.4x(Code G)	7.1x(Code H)	7.4x(Code H)		
No load current [A]	67.0	66.4	74.0	80.5		
Rated speed [RPM]	3570	2965	2970	2970		
Slip [%]	0.83	1.17	1.00	1.00		
Rated torque [ft.lb]	294	310	309	309		
Locked rotor torque [%]	140	140	150	160		
Breakdown torque [%]	229	210	229	240		
Service factor	1.15	1.00	1.00	1.00		
Temperature rise	80 K	80 K	80 K	80 K		
Locked rotor time	37s (cold) 21s (hot)	25s (cold) 14s (hot)	23s (cold) 13s (hot)	23s (cold) 13s (hot)		
Noise level ²	85.0 dB(A)					
Efficiency (%)	25%	92.4	91.3	91.4	91.5	
	50%	93.0	92.8	92.8	92.9	
	75%	94.5	93.9	93.9	94.0	
	100%	95.0	95.4	95.4	95.4	
Power Factor	25%	0.54	0.57	0.52	0.48	
	50%	0.79	0.81	0.77	0.74	
	75%	0.86	0.86	0.85	0.83	
	100%	0.88	0.88	0.87	0.86	
Bearing type		Drive end : 6314 C3	Non drive end : 6212 Z C3	Foundation loads		
Sealing		: Without	: Without	Max. traction	: 1346 lb	
		Bearing Seal	Bearing Seal	Max. compression	: 2613 lb	
Lubrication interval		: 14418 h	20000 h			
Lubricant amount		: 27 g	13 g			
Lubricant type		: Mobil Polyrex EM				
Notes						
This revision replaces and cancel the previous one, which must be eliminated. (1) Looking the motor from the shaft end. (2) Measured at 1m and with tolerance of +3dB(A). (3) Approximate weight subject to changes after manufacturing process. (4) At 100% of full load.			These are average values based on tests with sinusoidal power supply, subject to the tolerances stipulated in NEMA MG-1.			
Rev.	Changes Summary			Performed	Checked	Date
Performed by						
Checked by					Page	Revision
Date	14/04/2022				1 / 21	

TORQUE AND CURRENT VS SPEED CURVE

Three Phase Induction Motor - Squirrel Cage



Customer :

Product line : W40 NEMA Premium Efficiency
Three-Phase

Product code : 14026894

Catalog # : 200360T3G444TS-W40

TORQUE AND CURRENT VS SPEED CURVE

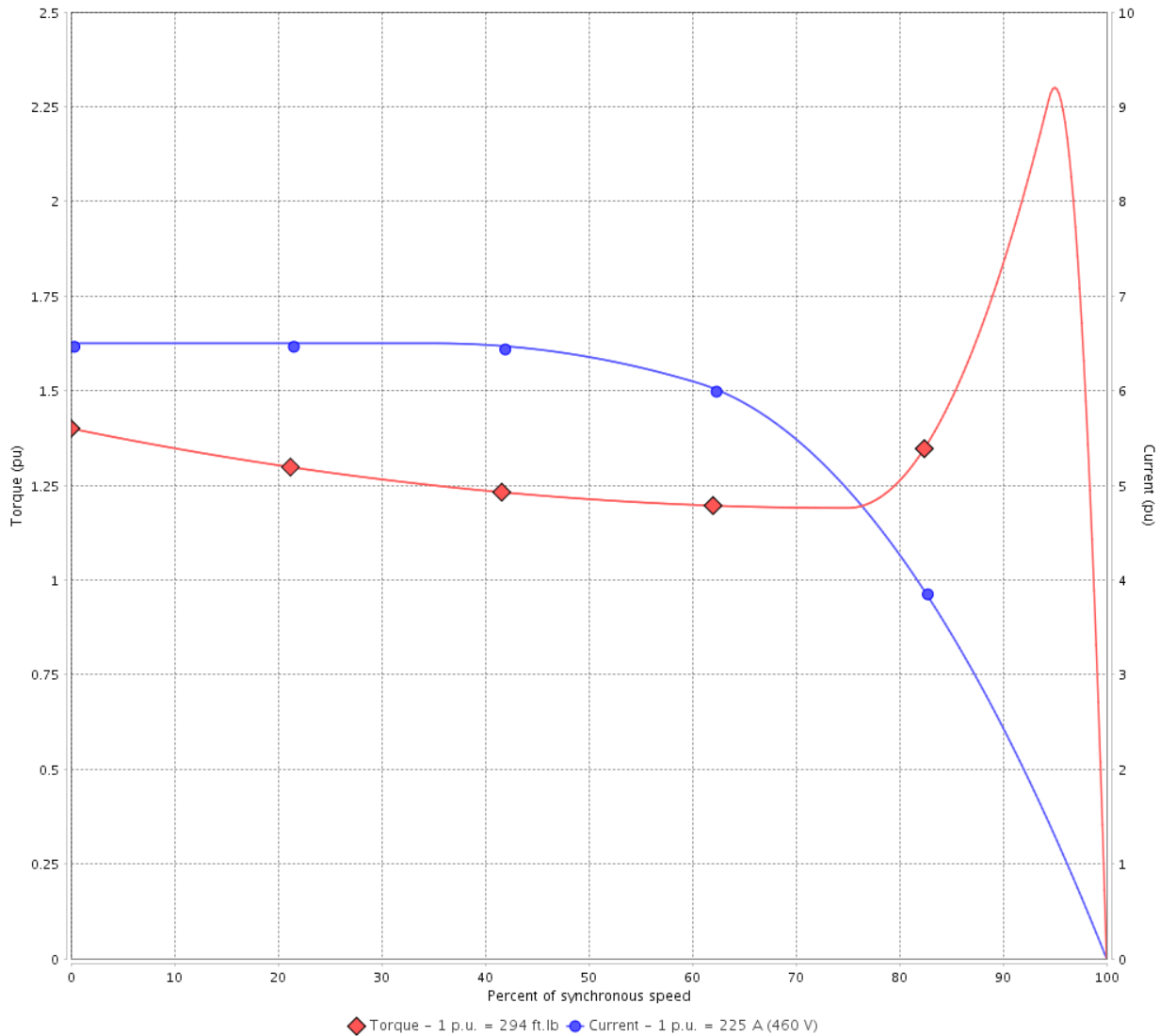

Performance : 460 V 60 Hz 2P

Rated current	: 225 A	Moment of inertia (J)	: 23.8 sq.ft.lb
LRC	: 6.5	Duty cycle	: Cont.(S1)
Rated torque	: 294 ft.lb	Insulation class	: F
Locked rotor torque	: 140 %	Service factor	: 1.15
Breakdown torque	: 229 %	Temperature rise	: 80 K
Rated speed	: 3570 rpm	Design	: B

Locked rotor time : 37s (cold) 21s (hot)

Rev.	Changes Summary	Performed	Checked	Date
Performed by			Page 2 / 21	Revision
Checked by				
Date	14/04/2022			

TORQUE AND CURRENT VS SPEED CURVE



Three Phase Induction Motor - Squirrel Cage

Customer :

Product line : W40 NEMA Premium Efficiency
Three-Phase

Product code : 14026894

Catalog # : 20036OT3G444TS-W40

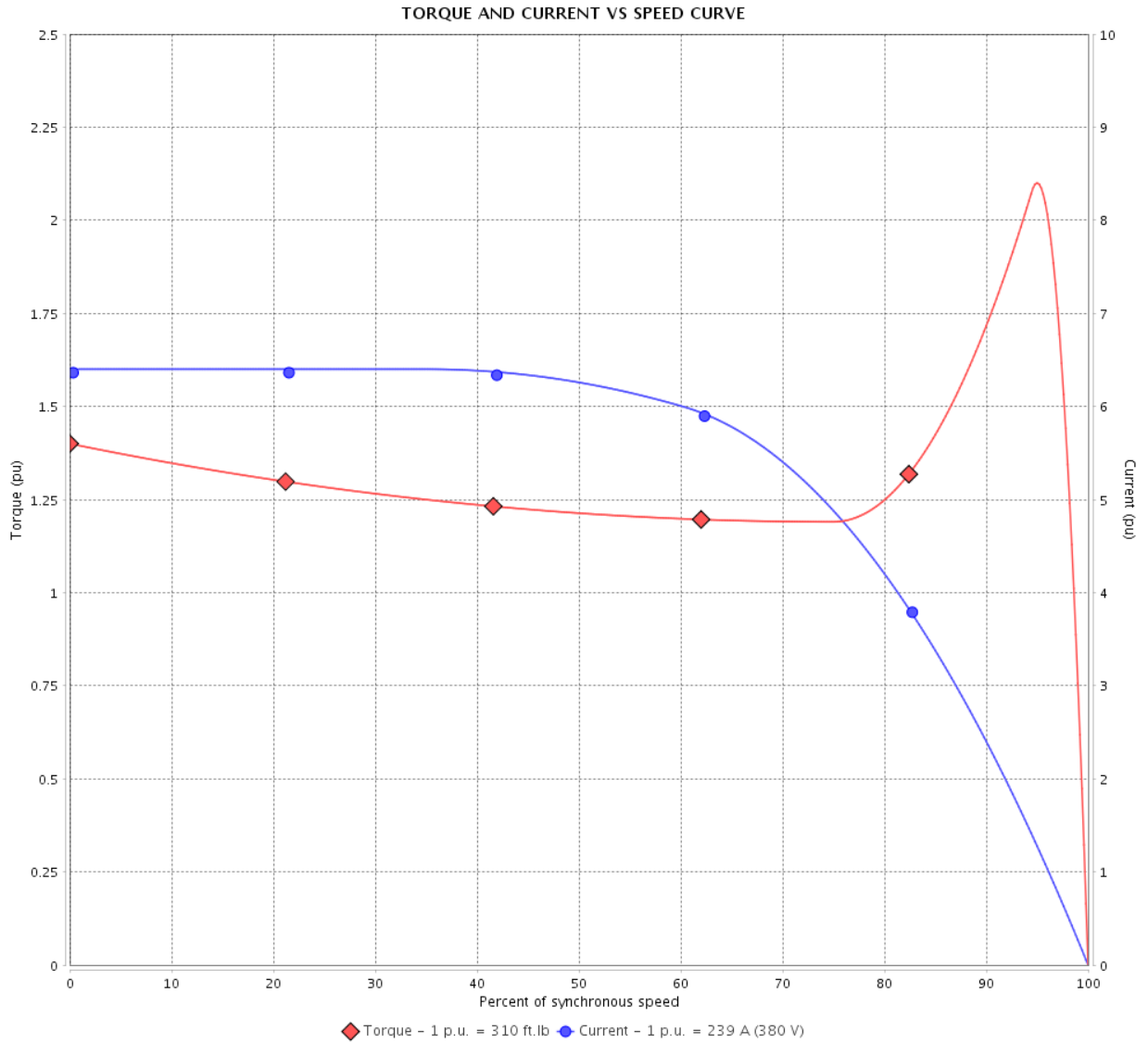

Performance : 380 V 50 Hz 2P IE3

Rated current	: 239 A	Moment of inertia (J)	: 23.8 sq.ft.lb
LRC	: 6.4	Duty cycle	: Cont.(S1)
Rated torque	: 310 ft.lb	Insulation class	: F
Locked rotor torque	: 140 %	Service factor	: 1.00
Breakdown torque	: 210 %	Temperature rise	: 80 K
Rated speed	: 2965 rpm	Design	: B

Locked rotor time : 25s (cold) 14s (hot)

Rev.	Changes Summary	Performed	Checked	Date
Performed by			Page 3 / 21	Revision
Checked by				
Date	14/04/2022			

TORQUE AND CURRENT VS SPEED CURVE

Three Phase Induction Motor - Squirrel Cage



Customer :

Product line : W40 NEMA Premium Efficiency
Three-Phase

Product code : 14026894

Catalog # : 200360T3G444TS-W40

TORQUE AND CURRENT VS SPEED CURVE

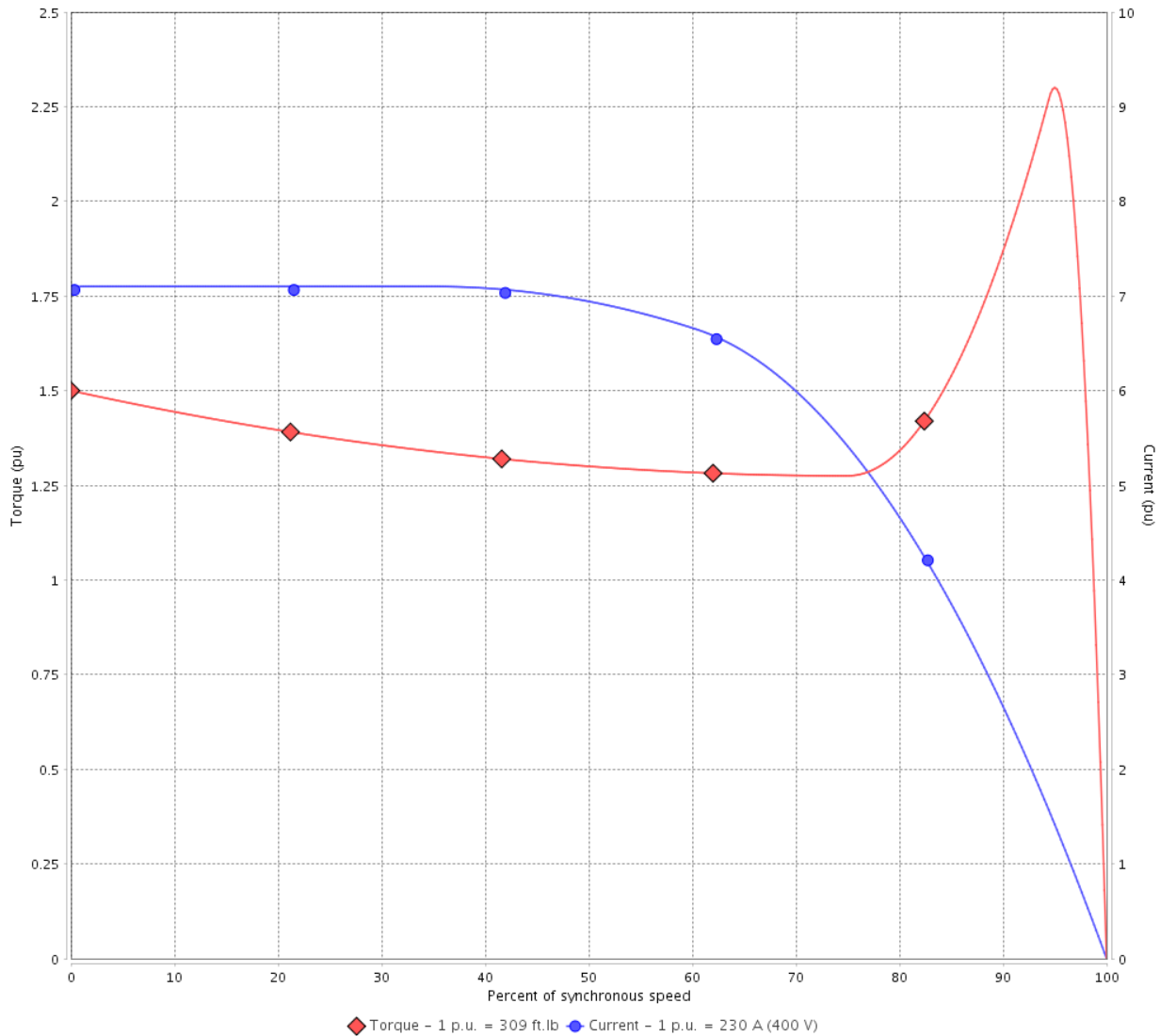

Performance : 400 V 50 Hz 2P IE3

Rated current	: 230 A	Moment of inertia (J)	: 23.8 sq.ft.lb
LRC	: 7.1	Duty cycle	: Cont.(S1)
Rated torque	: 309 ft.lb	Insulation class	: F
Locked rotor torque	: 150 %	Service factor	: 1.00
Breakdown torque	: 229 %	Temperature rise	: 80 K
Rated speed	: 2970 rpm	Design	: B

Locked rotor time : 23s (cold) 13s (hot)

Rev.	Changes Summary	Performed	Checked	Date
Performed by			Page	Revision
Checked by				
Date	14/04/2022			
			4 / 21	

TORQUE AND CURRENT VS SPEED CURVE



Three Phase Induction Motor - Squirrel Cage

Customer :

Product line : W40 NEMA Premium Efficiency Three-Phase

Product code : 14026894

Catalog # : 20036OT3G444TS-W40

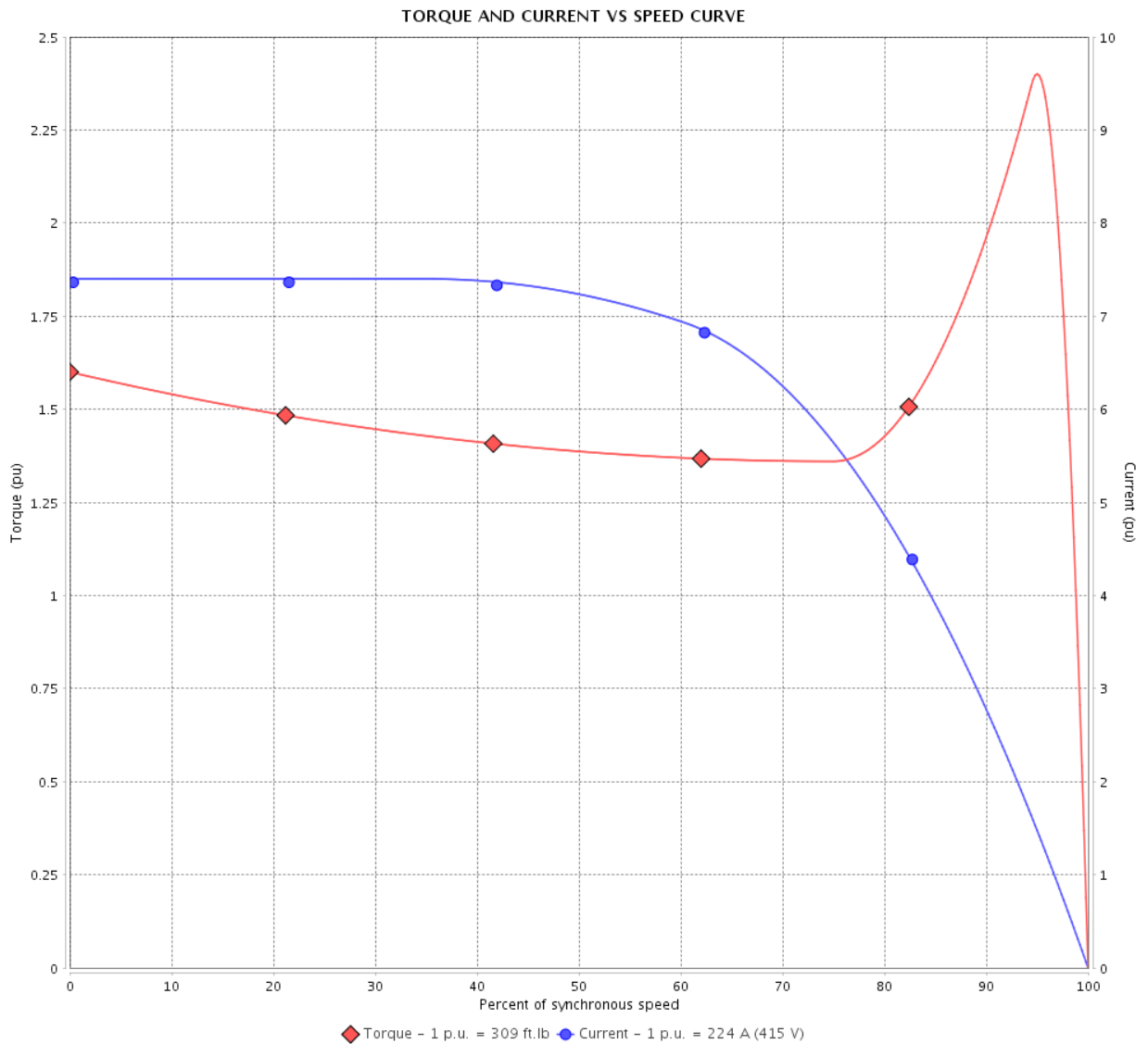

Performance : 415 V 50 Hz 2P IE3

Rated current	: 224 A	Moment of inertia (J)	: 23.8 sq.ft.lb
LRC	: 7.4	Duty cycle	: Cont.(S1)
Rated torque	: 309 ft.lb	Insulation class	: F
Locked rotor torque	: 160 %	Service factor	: 1.00
Breakdown torque	: 240 %	Temperature rise	: 80 K
Rated speed	: 2970 rpm	Design	: B

Locked rotor time : 23s (cold) 13s (hot)

Rev.	Changes Summary	Performed	Checked	Date
Performed by			Page 5 / 21	Revision
Checked by				
Date	14/04/2022			

LOAD PERFORMANCE CURVE

Three Phase Induction Motor - Squirrel Cage



Customer :

Product line : W40 NEMA Premium Efficiency Three-Phase

Product code : 14026894

Catalog # : 20036OT3G444TS-W40

LOAD PERFORMANCE CURVE

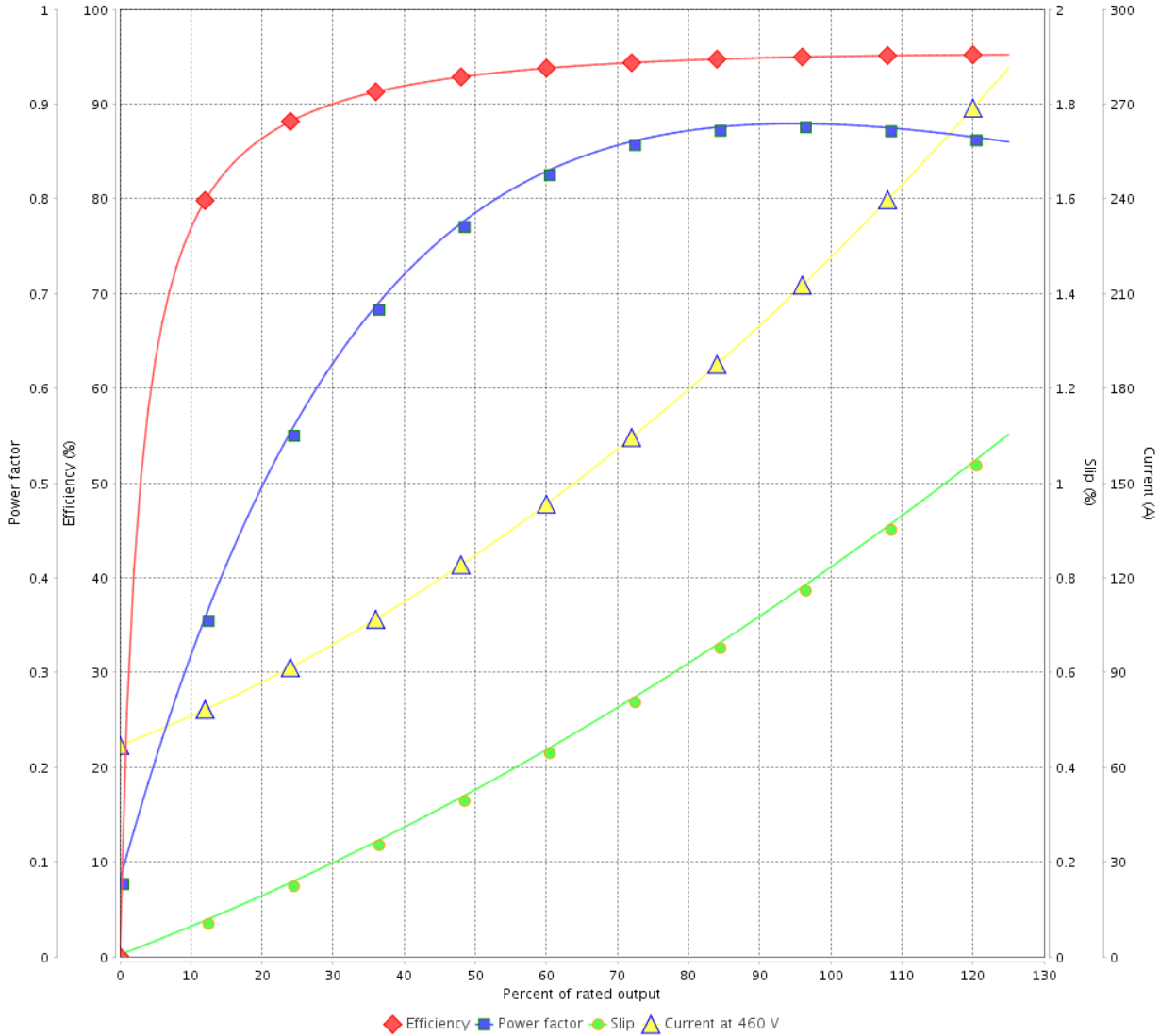

Performance : 460 V 60 Hz 2P

Rated current : 225 A
 LRC : 6.5
 Rated torque : 294 ft.lb
 Locked rotor torque : 140 %
 Breakdown torque : 229 %
 Rated speed : 3570 rpm

Moment of inertia (J) : 23.8 sq.ft.lb
 Duty cycle : Cont.(S1)
 Insulation class : F
 Service factor : 1.15
 Temperature rise : 80 K
 Design : B

Rev.	Changes Summary	Performed	Checked	Date
Performed by			Page	Revision
Checked by			6 / 21	
Date	14/04/2022			

LOAD PERFORMANCE CURVE

Three Phase Induction Motor - Squirrel Cage



Customer : _____

Product line : W40 NEMA Premium Efficiency
Three-Phase

Product code : 14026894

Catalog # : 20036OT3G444TS-W40

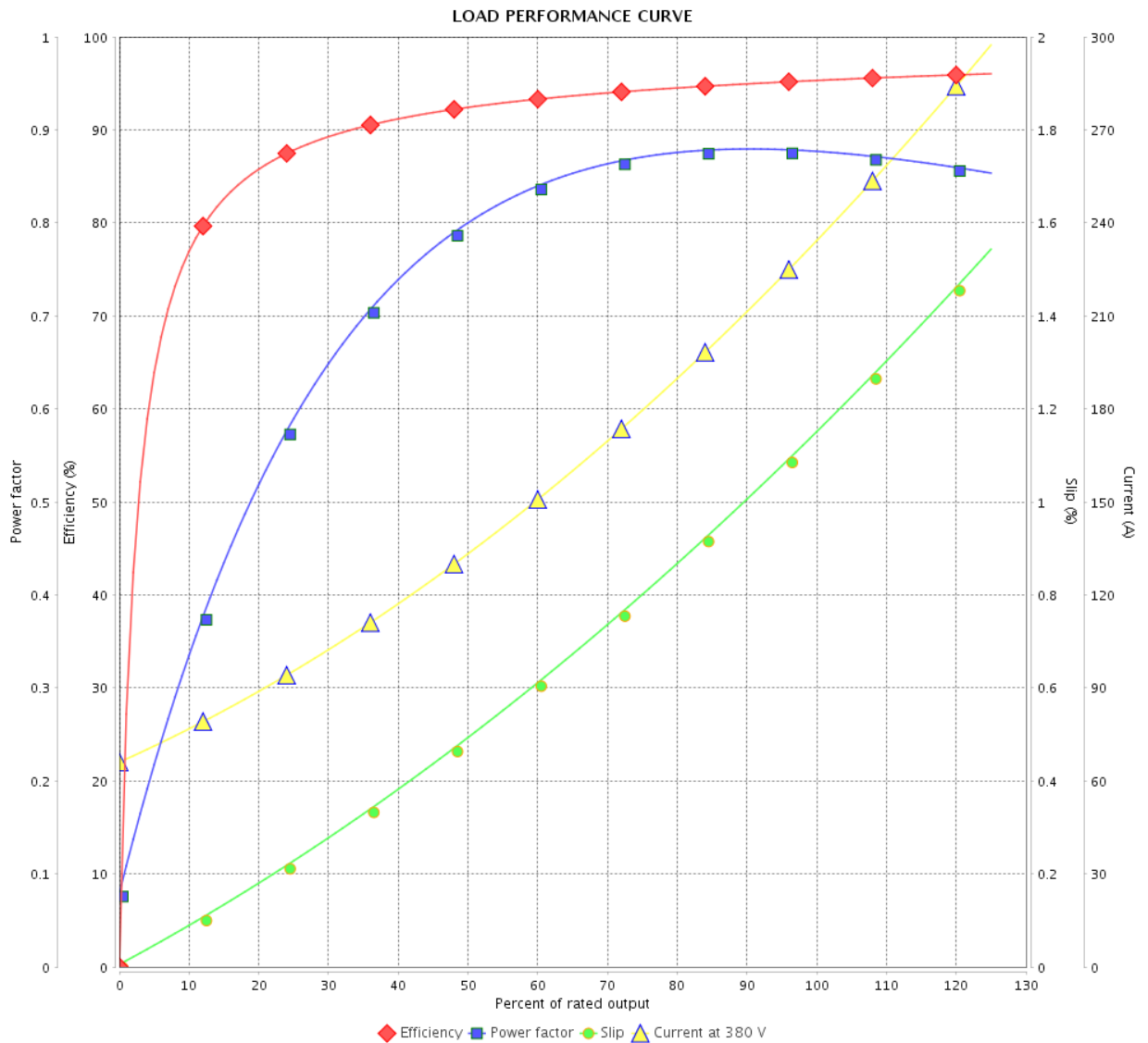

Performance : 380 V 50 Hz 2P IE3

Rated current : 239 A
 LRC : 6.4
 Rated torque : 310 ft.lb
 Locked rotor torque : 140 %
 Breakdown torque : 210 %
 Rated speed : 2965 rpm

Moment of inertia (J) : 23.8 sq.ft.lb
 Duty cycle : Cont.(S1)
 Insulation class : F
 Service factor : 1.00
 Temperature rise : 80 K
 Design : B

Rev.	Changes Summary	Performed	Checked	Date
Performed by				
Checked by				
Date				
		Page	Revision	
		7 / 21		

LOAD PERFORMANCE CURVE

Three Phase Induction Motor - Squirrel Cage



Customer :

Product line : W40 NEMA Premium Efficiency
Three-Phase

Product code : 14026894

Catalog # : 20036OT3G444TS-W40

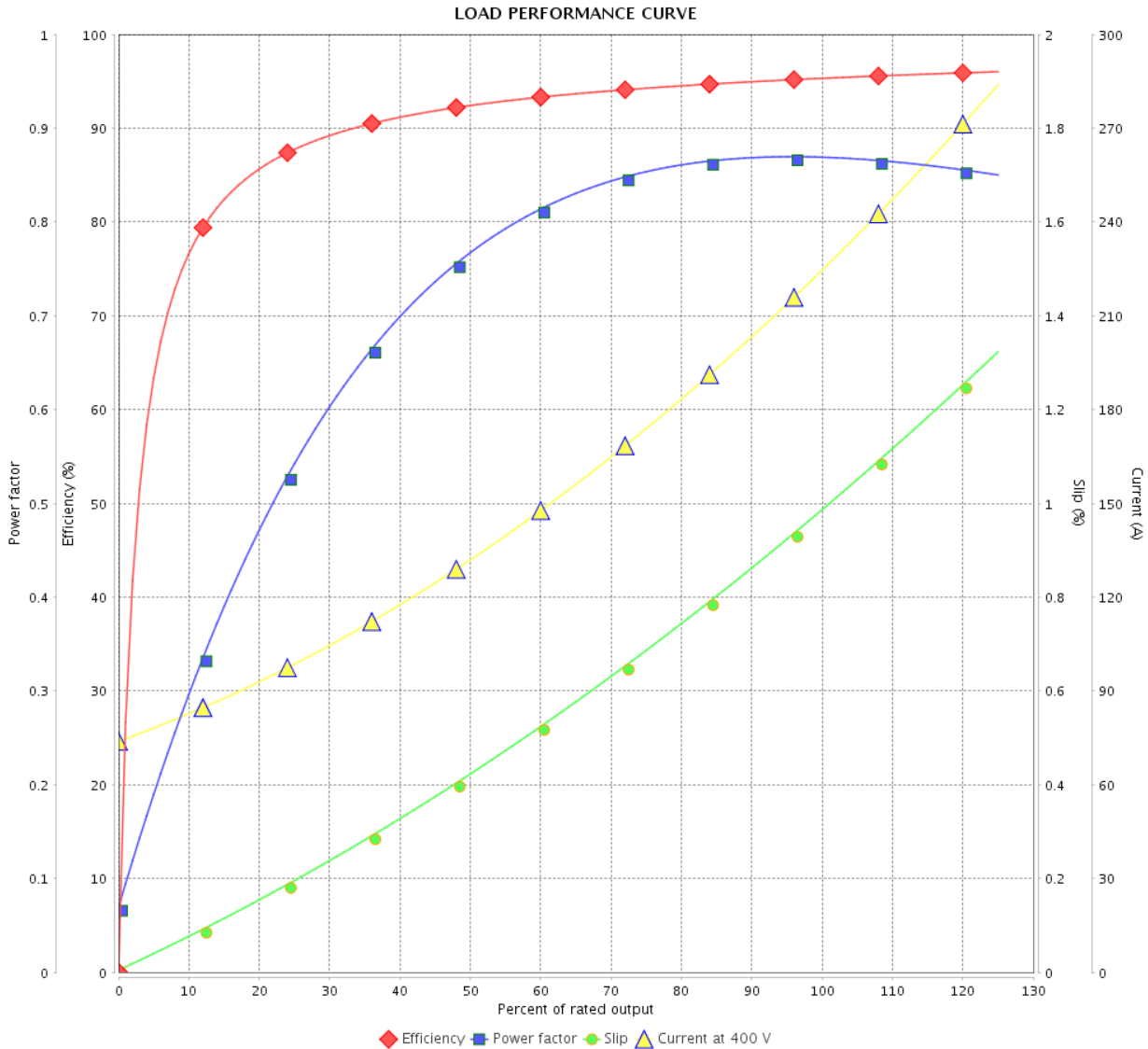

Performance : 400 V 50 Hz 2P IE3

Rated current	: 230 A	Moment of inertia (J)	: 23.8 sq.ft.lb
LRC	: 7.1	Duty cycle	: Cont.(S1)
Rated torque	: 309 ft.lb	Insulation class	: F
Locked rotor torque	: 150 %	Service factor	: 1.00
Breakdown torque	: 229 %	Temperature rise	: 80 K
Rated speed	: 2970 rpm	Design	: B

Rev.	Changes Summary	Performed	Checked	Date
Performed by			Page	Revision
Checked by			8 / 21	
Date	14/04/2022			

LOAD PERFORMANCE CURVE

Three Phase Induction Motor - Squirrel Cage



Customer : _____

Product line : W40 NEMA Premium Efficiency
Three-Phase

Product code : 14026894

Catalog # : 20036OT3G444TS-W40

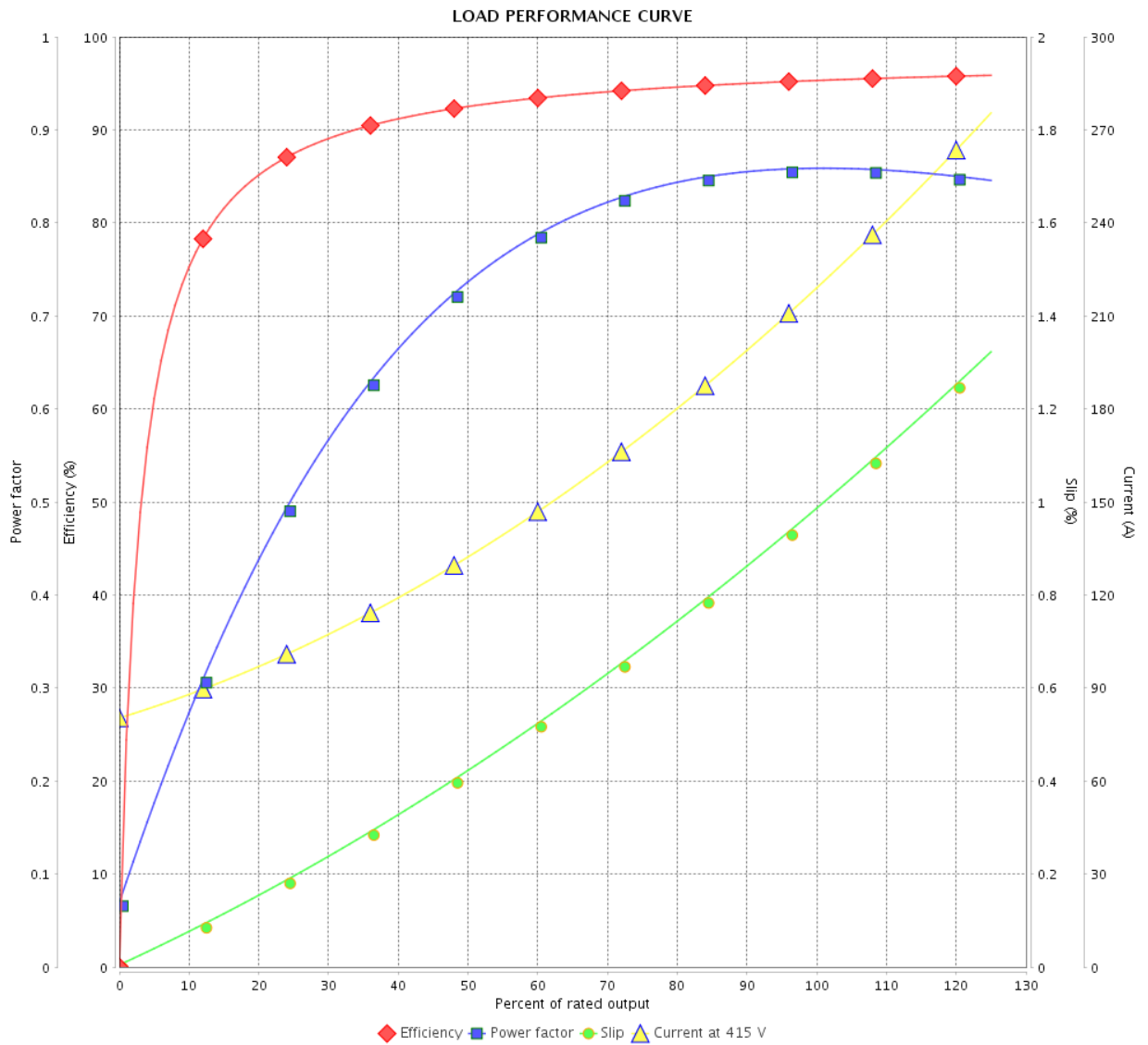

Performance : 415 V 50 Hz 2P IE3

Rated current : 224 A
 LRC : 7.4
 Rated torque : 309 ft.lb
 Locked rotor torque : 160 %
 Breakdown torque : 240 %
 Rated speed : 2970 rpm

Moment of inertia (J) : 23.8 sq.ft.lb
 Duty cycle : Cont.(S1)
 Insulation class : F
 Service factor : 1.00
 Temperature rise : 80 K
 Design : B

Rev.	Changes Summary	Performed	Checked	Date
Performed by		Page		Revision
Checked by		9 / 21		
Date		14/04/2022		

THERMAL LIMIT CURVE

Three Phase Induction Motor - Squirrel Cage



Customer :

Product line : W40 NEMA Premium Efficiency
Three-Phase

Product code : 14026894

Catalog # : 20036OT3G444TS-W40

Performance : 460 V 60 Hz 2P

Rated current	: 225 A	Moment of inertia (J)	: 23.8 sq.ft.lb
LRC	: 6.5	Duty cycle	: Cont.(S1)
Rated torque	: 294 ft.lb	Insulation class	: F
Locked rotor torque	: 140 %	Service factor	: 1.15
Breakdown torque	: 229 %	Temperature rise	: 80 K
Rated speed	: 3570 rpm	Design	: B

Heating constant

Cooling constant

Rev.	Changes Summary	Performed	Checked	Date
Performed by				
Checked by			Page	Revision
Date	14/04/2022		10 / 21	

THERMAL LIMIT CURVE

Three Phase Induction Motor - Squirrel Cage



Customer : _____

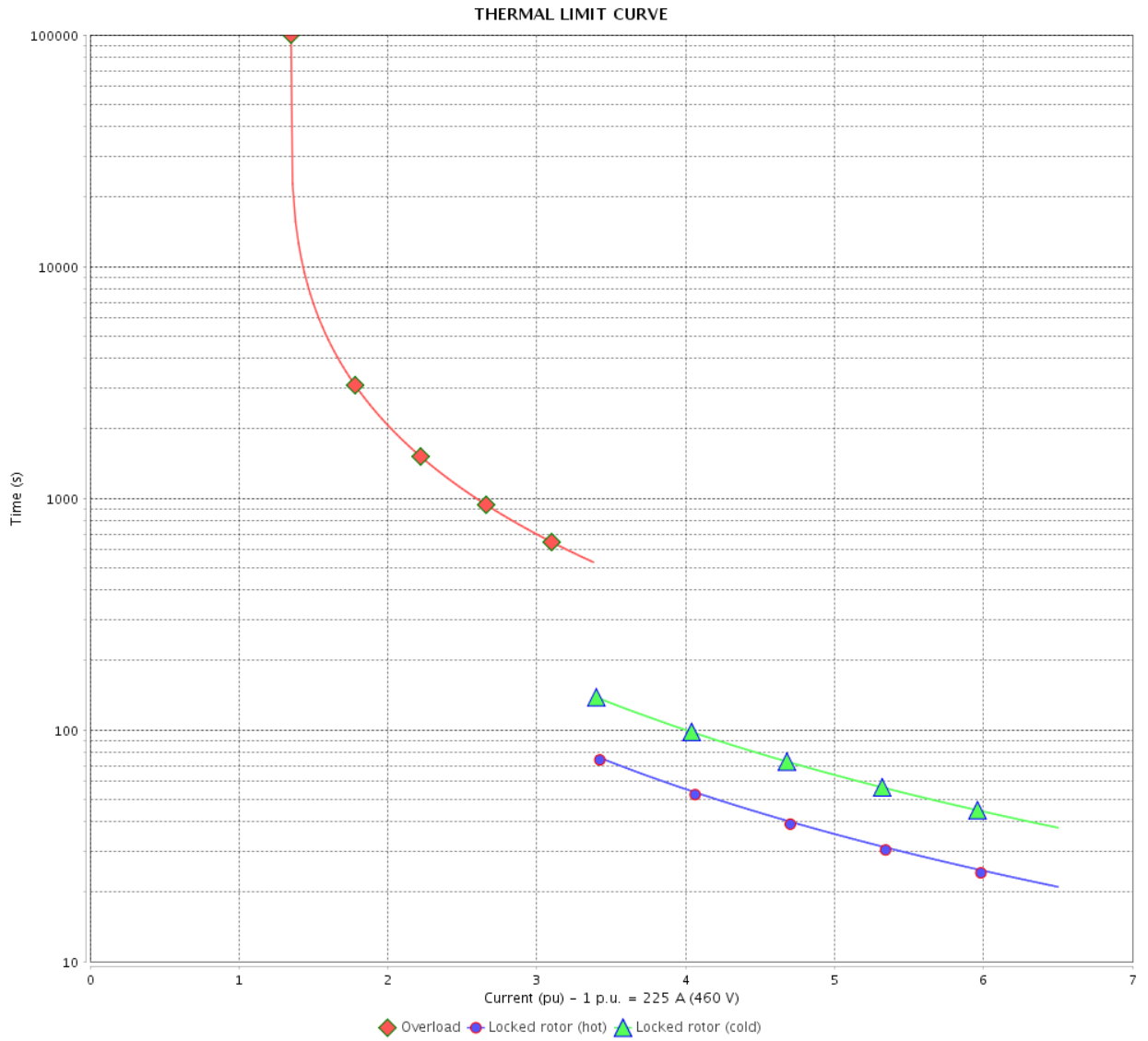

Rev.	Changes Summary	Performed	Checked	Date
Performed by		Page 11 / 21		Revision
Checked by				
Date				

THERMAL LIMIT CURVE

Three Phase Induction Motor - Squirrel Cage



Customer :

Product line : W40 NEMA Premium Efficiency
Three-Phase

Product code : 14026894

Catalog # : 20036OT3G444TS-W40

Performance : 380 V 50 Hz 2P IE3

Rated current	: 239 A	Moment of inertia (J)	: 23.8 sq.ft.lb
LRC	: 6.4	Duty cycle	: Cont.(S1)
Rated torque	: 310 ft.lb	Insulation class	: F
Locked rotor torque	: 140 %	Service factor	: 1.00
Breakdown torque	: 210 %	Temperature rise	: 80 K
Rated speed	: 2965 rpm	Design	: B

Heating constant

Cooling constant

Rev.	Changes Summary	Performed	Checked	Date
Performed by				
Checked by			Page	Revision
Date	14/04/2022		12 / 21	

THERMAL LIMIT CURVE

Three Phase Induction Motor - Squirrel Cage



Customer : _____

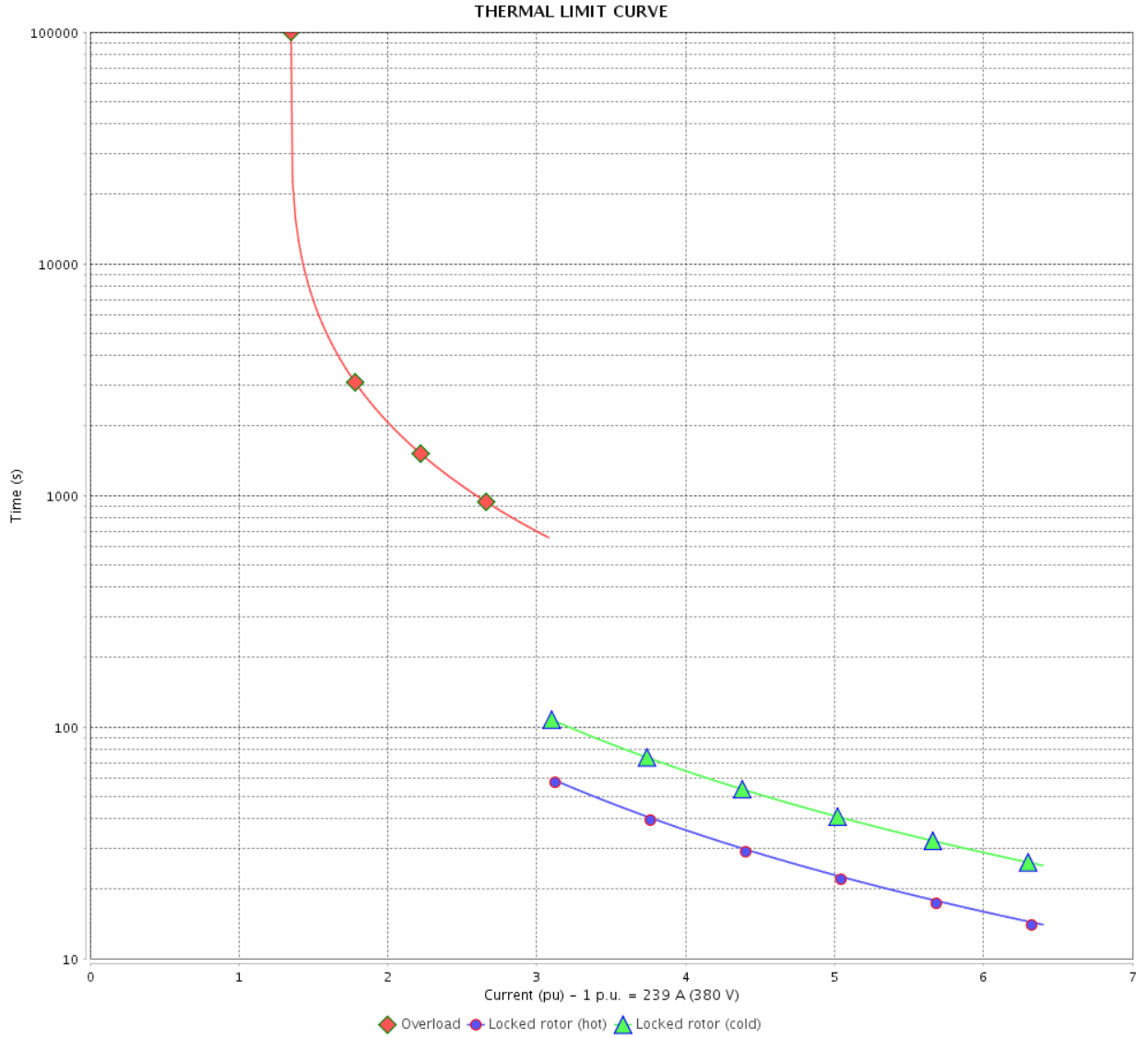

Rev.	Changes Summary	Performed	Checked	Date
Performed by		Page		Revision
Checked by		13 / 21		
Date		14/04/2022		

THERMAL LIMIT CURVE



Three Phase Induction Motor - Squirrel Cage

Customer :

Product line : W40 NEMA Premium Efficiency
Three-Phase

Product code : 14026894

Catalog # : 20036OT3G444TS-W40

Performance : 400 V 50 Hz 2P IE3

Rated current	: 230 A	Moment of inertia (J)	: 23.8 sq.ft.lb
LRC	: 7.1	Duty cycle	: Cont.(S1)
Rated torque	: 309 ft.lb	Insulation class	: F
Locked rotor torque	: 150 %	Service factor	: 1.00
Breakdown torque	: 229 %	Temperature rise	: 80 K
Rated speed	: 2970 rpm	Design	: B

Heating constant

Cooling constant

Rev.	Changes Summary	Performed	Checked	Date
Performed by				
Checked by			Page	Revision
Date	14/04/2022		14 / 21	

THERMAL LIMIT CURVE

Three Phase Induction Motor - Squirrel Cage



Customer : _____

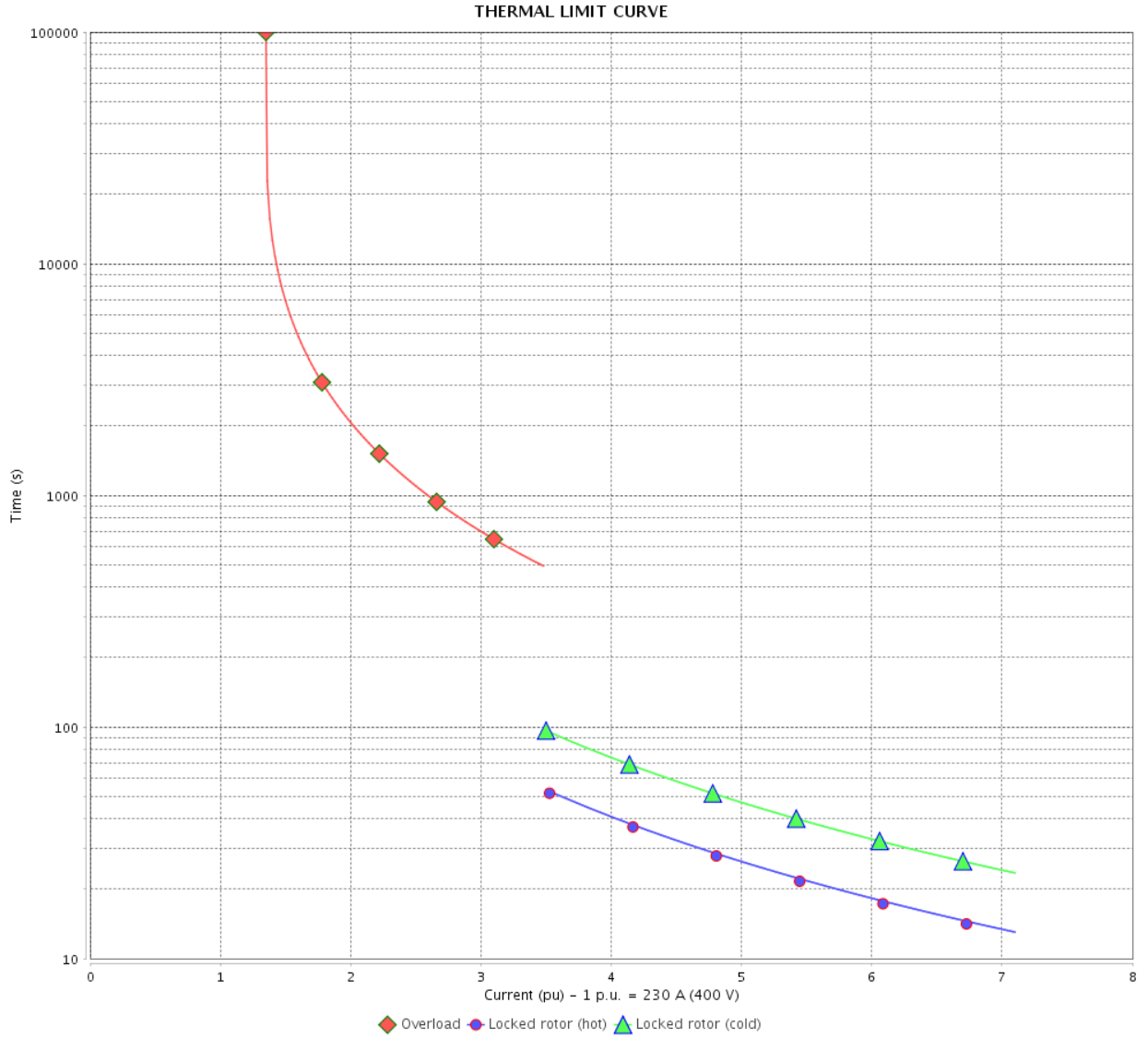

Rev.	Changes Summary	Performed	Checked	Date
Performed by				
Checked by				
Date				
			Page	Revision
			15 / 21	

THERMAL LIMIT CURVE

Three Phase Induction Motor - Squirrel Cage



Customer :

Product line : W40 NEMA Premium Efficiency
Three-Phase

Product code : 14026894

Catalog # : 20036OT3G444TS-W40

Performance : 415 V 50 Hz 2P IE3

Rated current	: 224 A	Moment of inertia (J)	: 23.8 sq.ft.lb
LRC	: 7.4	Duty cycle	: Cont.(S1)
Rated torque	: 309 ft.lb	Insulation class	: F
Locked rotor torque	: 160 %	Service factor	: 1.00
Breakdown torque	: 240 %	Temperature rise	: 80 K
Rated speed	: 2970 rpm	Design	: B

Heating constant

Cooling constant

Rev.	Changes Summary	Performed	Checked	Date
Performed by				
Checked by			Page	Revision
Date	14/04/2022		16 / 21	

THERMAL LIMIT CURVE

Three Phase Induction Motor - Squirrel Cage



Customer : _____

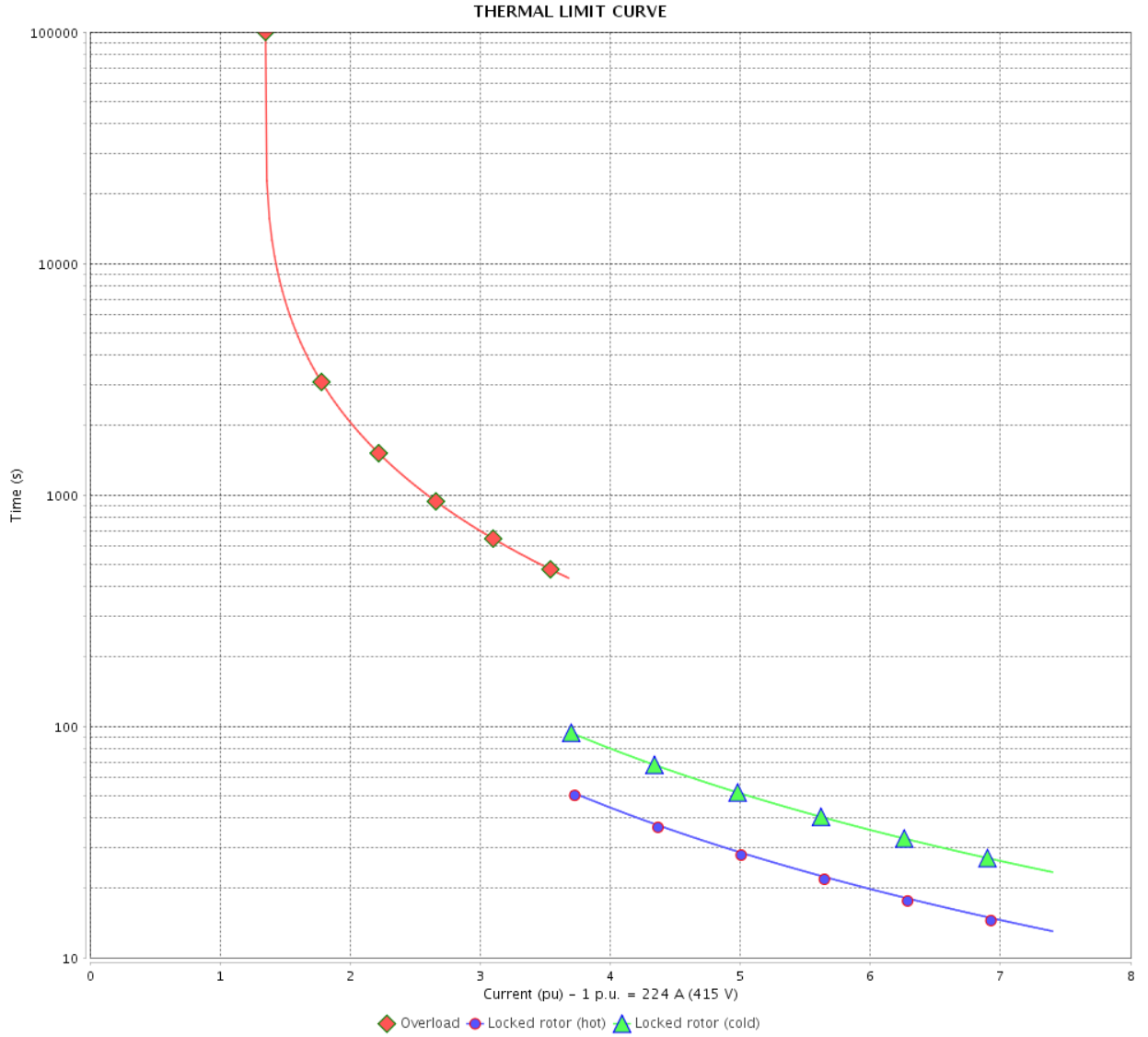

Rev.	Changes Summary	Performed	Checked	Date
Performed by				
Checked by				
Date				
		Page	Revision	
		17 / 21		

VFD OPERATION CURVE

Three Phase Induction Motor - Squirrel Cage



Customer :

Product line : W40 NEMA Premium Efficiency Three-Phase

Product code : 14026894

Catalog # : 20036OT3G444TS-W40

VFD OPERATION CURVE

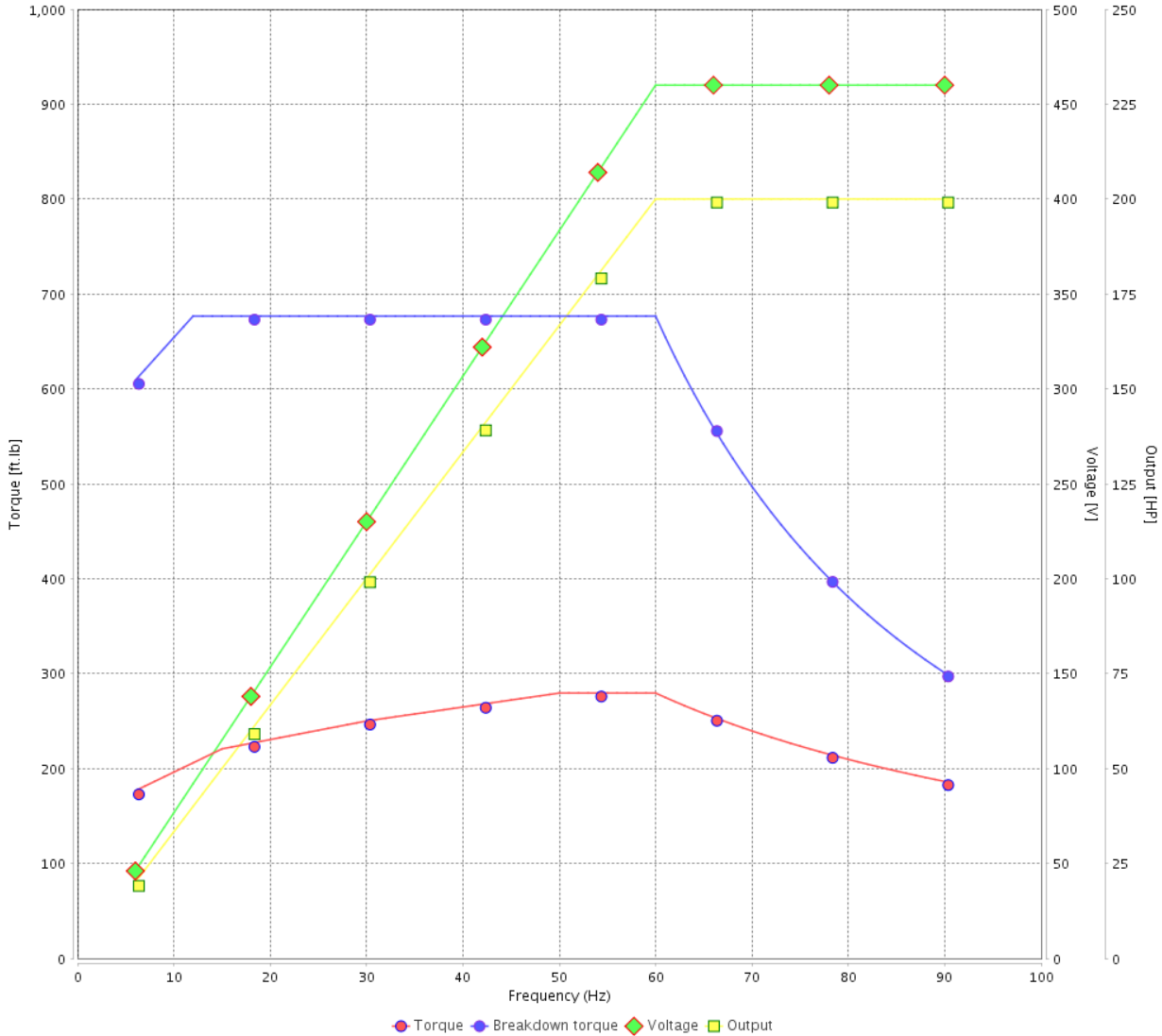

Performance : 460 V 60 Hz 2P

Rated current : 225 A
 LRC : 6.5
 Rated torque : 294 ft.lb
 Locked rotor torque : 140 %
 Breakdown torque : 229 %
 Rated speed : 3570 rpm

Moment of inertia (J) : 23.8 sq.ft.lb
 Duty cycle : Cont.(S1)
 Insulation class : F
 Service factor : 1.15
 Temperature rise : 80 K
 Design : B

Rev.	Changes Summary	Performed	Checked	Date
Performed by			Page 18 / 21	Revision
Checked by				
Date	14/04/2022			

VFD OPERATION CURVE

Three Phase Induction Motor - Squirrel Cage



Customer :

Product line : W40 NEMA Premium Efficiency
Three-Phase

Product code : 14026894

Catalog # : 20036OT3G444TS-W40

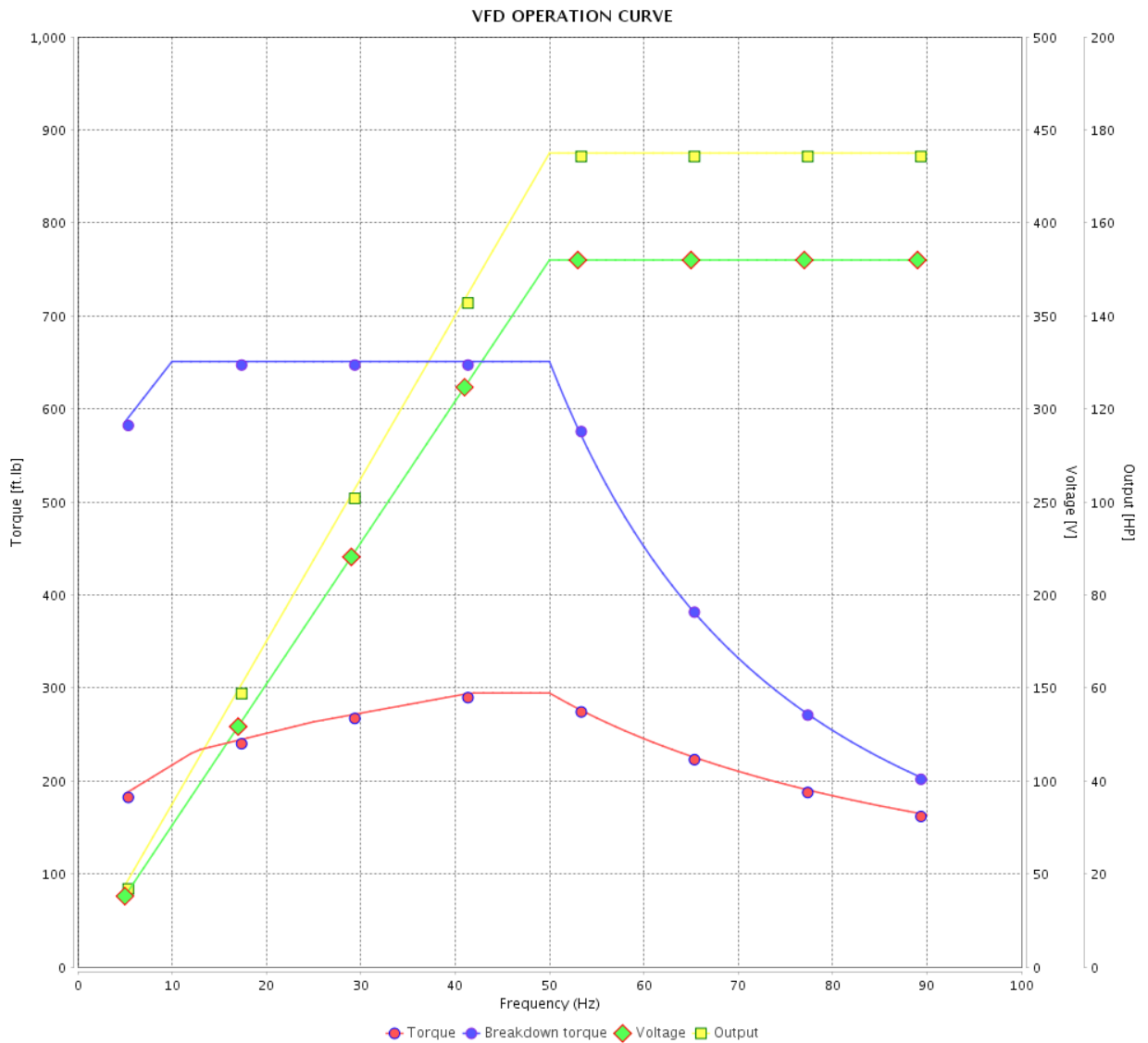

Performance : 380 V 50 Hz 2P IE3

Rated current : 239 A
LRC : 6.4
Rated torque : 310 ft.lb
Locked rotor torque : 140 %
Breakdown torque : 210 %
Rated speed : 2965 rpm

Moment of inertia (J) : 23.8 sq.ft.lb
Duty cycle : Cont.(S1)
Insulation class : F
Service factor : 1.00
Temperature rise : 80 K
Design : B

Rev.	Changes Summary	Performed	Checked	Date
Performed by		Page		Revision
Checked by		19 / 21		
Date		14/04/2022		

VFD OPERATION CURVE

Three Phase Induction Motor - Squirrel Cage



Customer :

Product line : W40 NEMA Premium Efficiency
Three-Phase

Product code : 14026894

Catalog # : 20036OT3G444TS-W40

VFD OPERATION CURVE

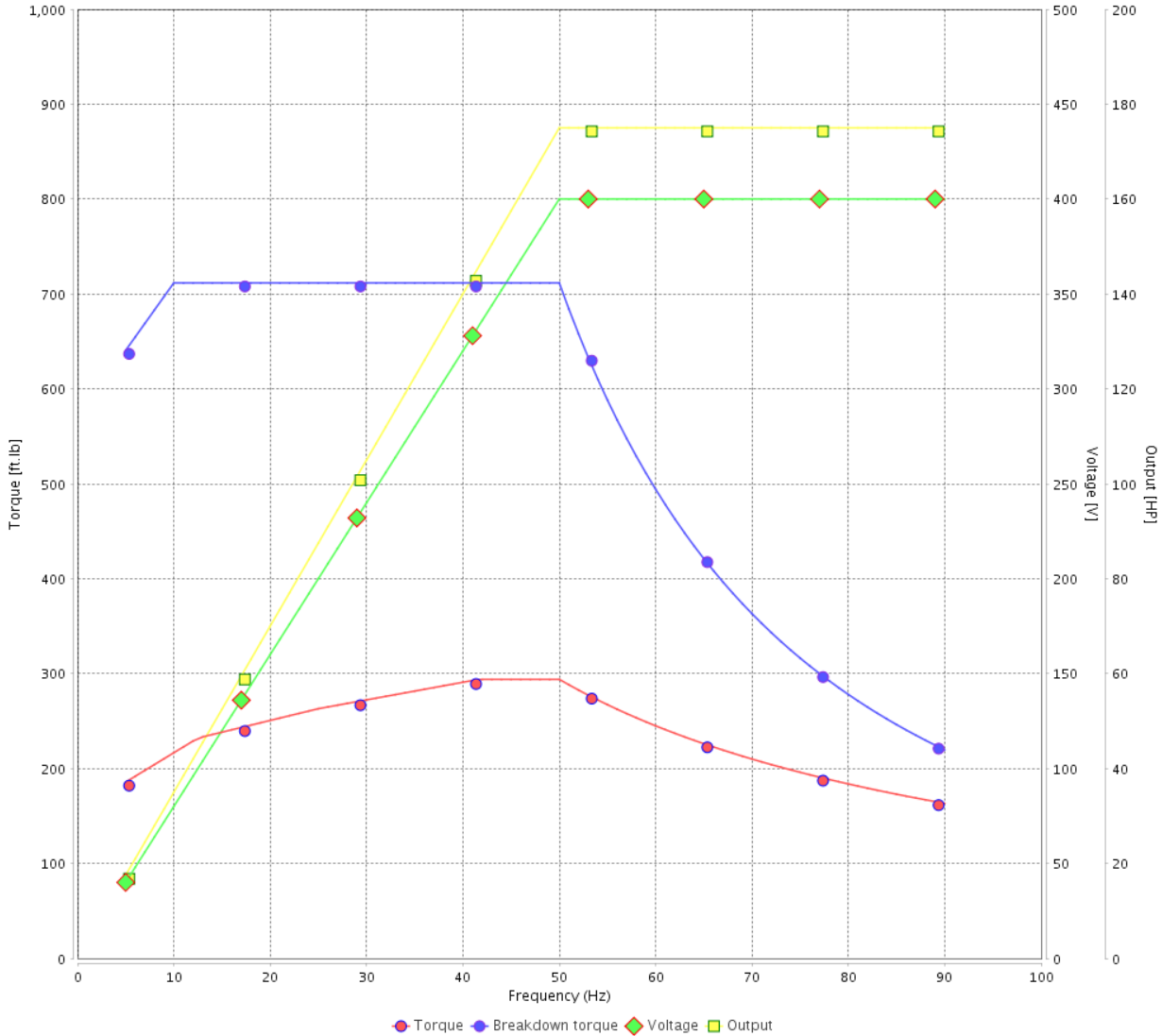

Performance : 400 V 50 Hz 2P IE3

Rated current : 230 A
LRC : 7.1
Rated torque : 309 ft.lb
Locked rotor torque : 150 %
Breakdown torque : 229 %
Rated speed : 2970 rpm

Moment of inertia (J) : 23.8 sq.ft.lb
Duty cycle : Cont.(S1)
Insulation class : F
Service factor : 1.00
Temperature rise : 80 K
Design : B

Rev.	Changes Summary	Performed	Checked	Date
Performed by			Page 20 / 21	Revision
Checked by				
Date	14/04/2022			

VFD OPERATION CURVE

Three Phase Induction Motor - Squirrel Cage



Customer :

Product line : W40 NEMA Premium Efficiency Three-Phase

Product code : 14026894

Catalog # : 20036OT3G444TS-W40

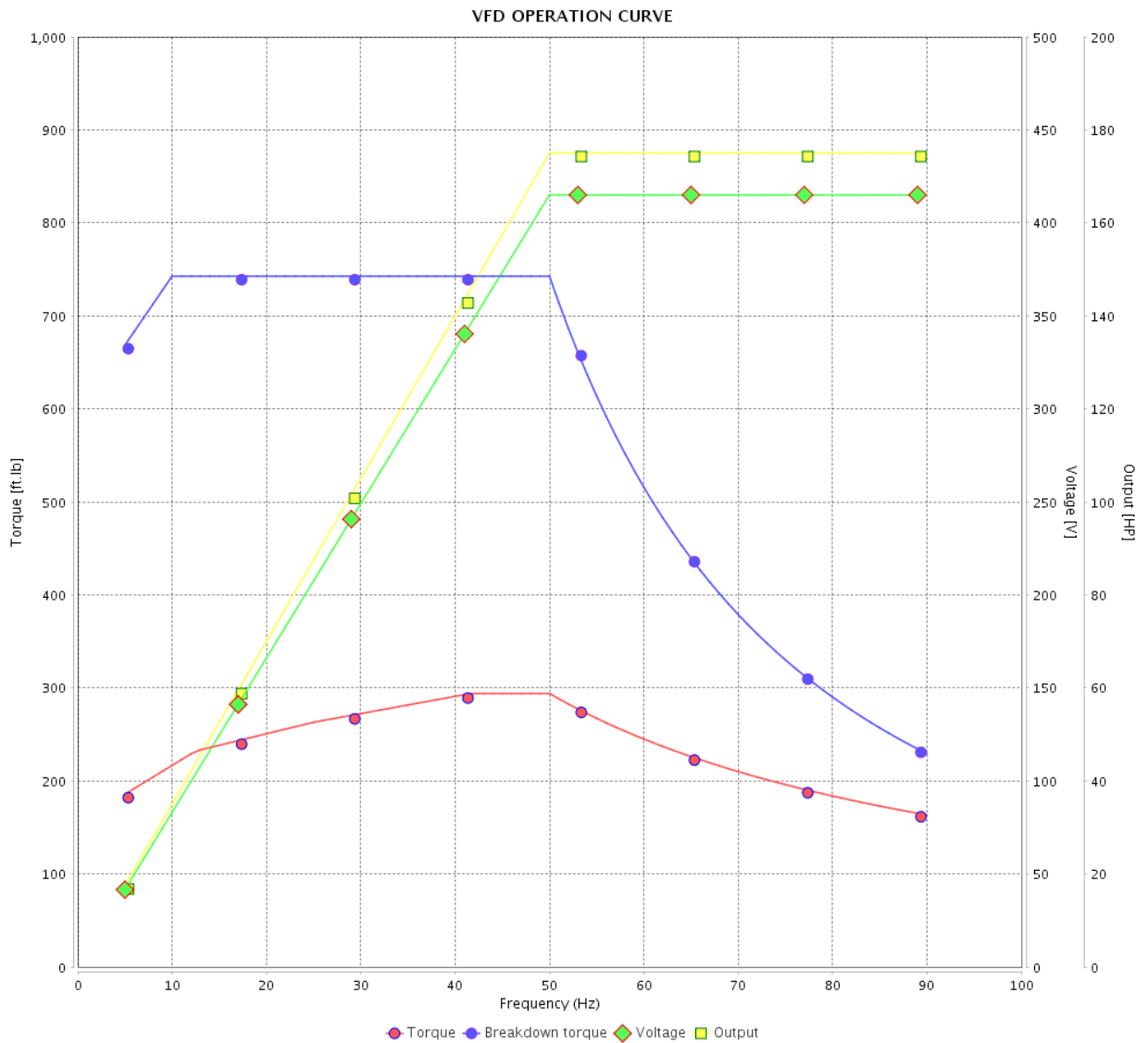

Performance : 415 V 50 Hz 2P IE3

Rated current : 224 A
 LRC : 7.4
 Rated torque : 309 ft.lb
 Locked rotor torque : 160 %
 Breakdown torque : 240 %
 Rated speed : 2970 rpm

Moment of inertia (J) : 23.8 sq.ft.lb
 Duty cycle : Cont.(S1)
 Insulation class : F
 Service factor : 1.00
 Temperature rise : 80 K
 Design : B

Rev.	Changes Summary	Performed	Checked	Date
Performed by			Page	Revision
Checked by				
Date				

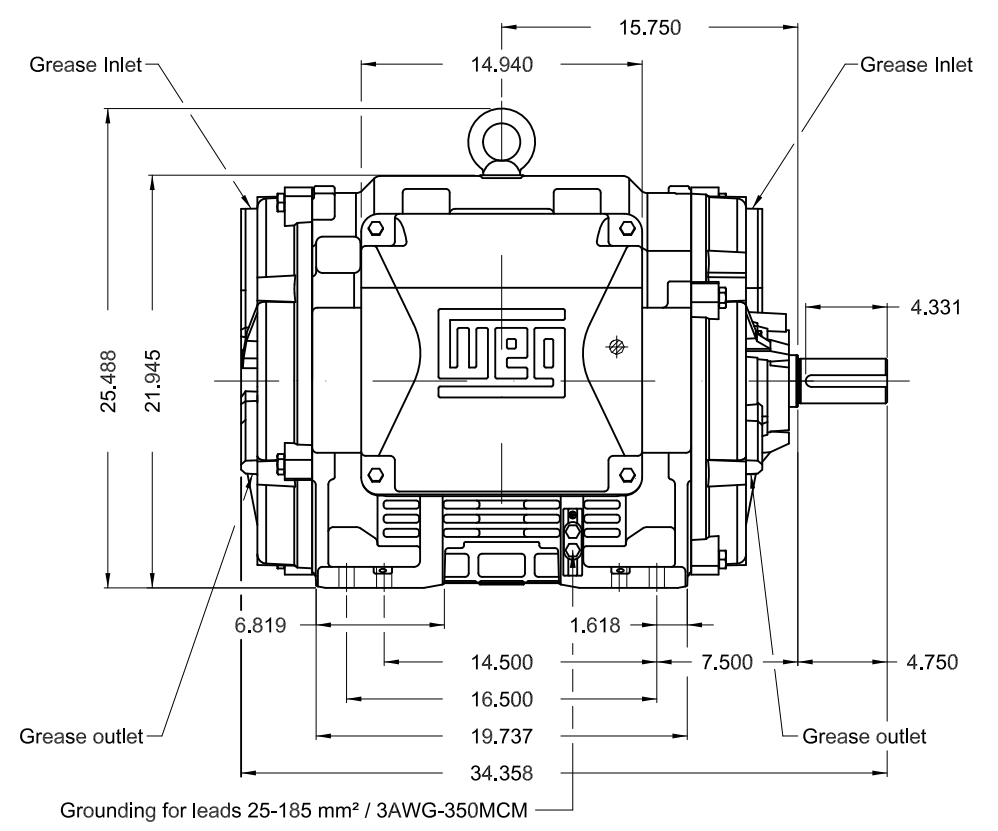
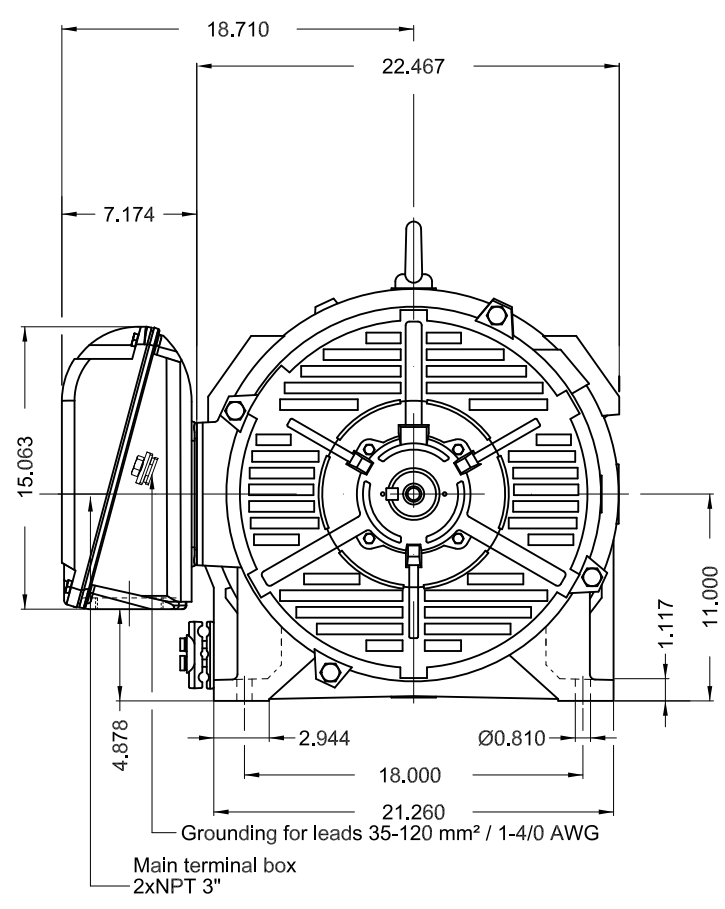

Color RAL 5009
 Painting plan 203A
 Mounting NEMA F-1
 Mounting B3R(D)

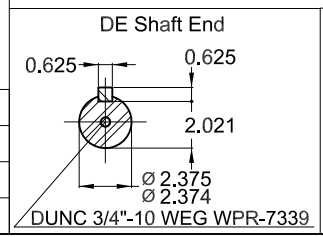

200 HP 02 Poles 60 Hz A

1:10

ECM	LOC	SUMMARY OF MODIFICATIONS	EXECUTED	CHECKED	RELEASED	DATE	VER
EXECUTED	PIRWBUSER	THREE PH. MOTOR W40 PREM. EFF.					
CHECKED		FRAME 444/5TS IP23 ODP					
RELEASED							
REL DT.	WMO	Jaragua do Sul	Product Engineering	SHEET	1 / 1		

PREVIEW
WDD

