

DATA SHEET



Three Phase Induction Motor - Squirrel Cage

Customer :				
Product line	: NEMA Premium Efficiency Three-Phase			
Product code :	13500652			
Catalog # :	35012ET3GKD580Z-W22			
Frame : 586/7TZ Output : 350 HP (260 kW) Poles : 6 Frequency : 60 Hz Rated voltage : 460 V Rated current : 425 A L. R. Amperes : 2593 A LRC : 6.1x(Code G) No load current : 190 A Rated speed : 1193 rpm Slip : 0.58 % Rated torque : 1540 ft.lb Locked rotor torque : 220 % Breakdown torque : 250 % Insulation class : F Service factor : 1.15 Design : A	Locked rotor time : 52s (cold) 29s (hot) Temperature rise : 80 K Duty cycle : Cont.(S1) Ambient temperature : -20°C to +40°C Altitude : 1000 m.a.s.l. Protection degree : IP55 Cooling method : IC411 - TEFC Mounting : F-1 Rotation ¹ : Both (CW and CCW) Noise level ² : 77.0 dB(A) Starting method : Direct On Line Approx. weight ³ : 3784 lb			
Output	25% 50% 75% 100%			
Efficiency (%)	0.000 95.4 95.8 95.8			
Power Factor	0.00 0.66 0.75 0.80			
Foundation loads				
Max. traction	: 6144 lb			
Max. compression	: 9928 lb			
Bearing type	: <u>Drive end</u> NU-324 C3 <u>Non drive end</u> 6319 C3			
Sealing	: Taconite Labyrinth Taconite Labyrinth			
Lubrication interval	: 6000 h 13000 h			
Lubricant amount	: 72 g 45 g			
Lubricant type	: Mobil Polyrex EM			
Notes				
This revision replaces and cancel the previous one, which must be eliminated. (1) Looking the motor from the shaft end. (2) Measured at 1m and with tolerance of +3dB(A). (3) Approximate weight subject to changes after manufacturing process. (4) At 100% of full load.				
These are average values based on tests with sinusoidal power supply, subject to the tolerances stipulated in NEMA MG-1.				
Rev.	Changes Summary	Performed	Checked	Date
Performed by				
Checked by			Page	Revision
Date	13/04/2022		1 / 7	

DATA SHEET

Three Phase Induction Motor - Squirrel Cage



Customer : _____

Thermal protection

ID	Application	Type	Quantity	Sensing Temperature
1	Winding	Thermostat - 2 wires	1 x Phase	155 °C

Space heater information

Voltage: 200 - 240 V

Rev.	Changes Summary	Performed	Checked	Date
Performed by				
Checked by			Page	Revision
Date	13/04/2022		2 / 7	

TORQUE AND CURRENT VS SPEED CURVE



Three Phase Induction Motor - Squirrel Cage

Customer :

Product line : NEMA Premium Efficiency Three-Phase

Product code : 13500652

Catalog # : 35012ET3GKD580Z-W22

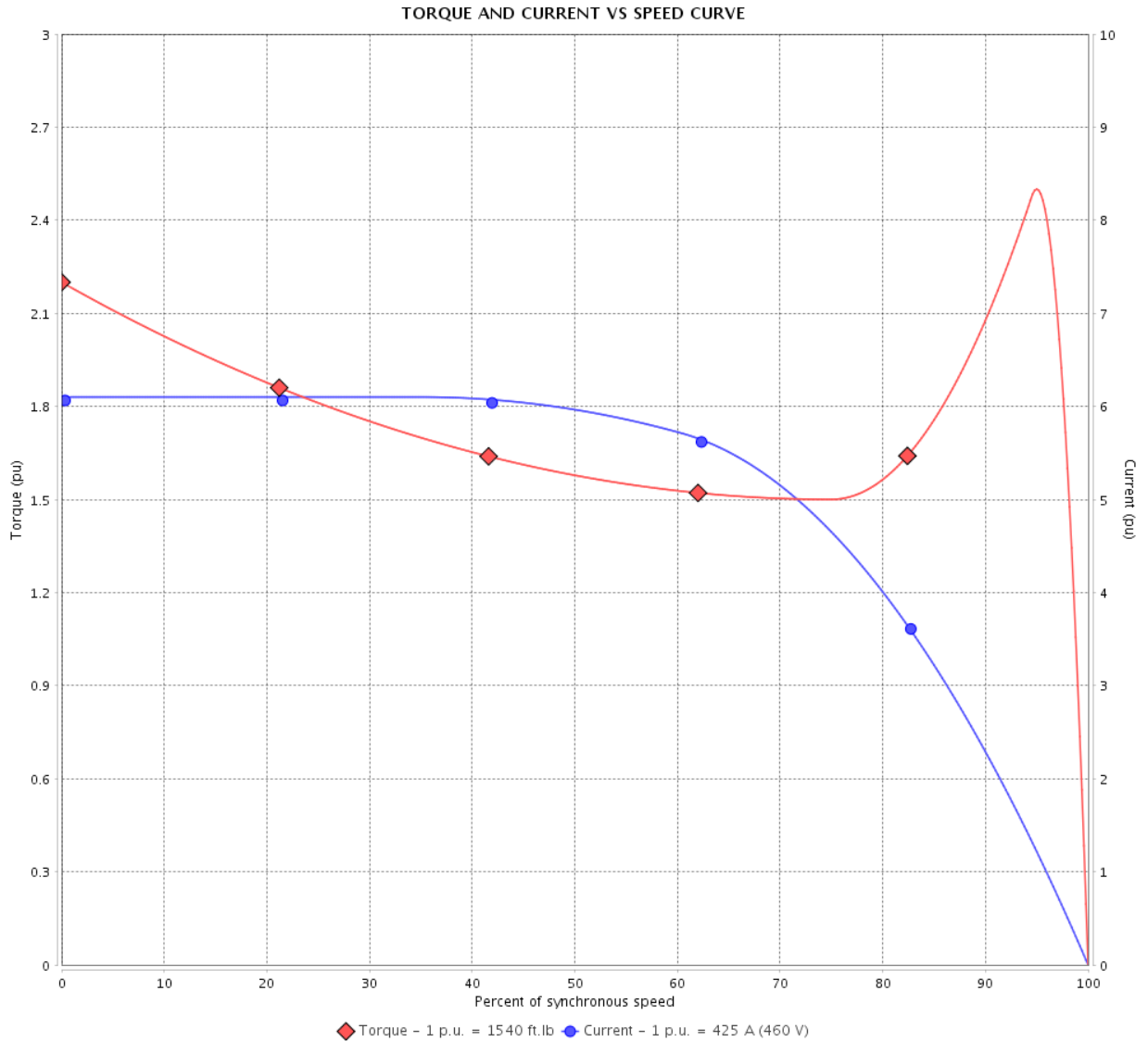

Performance : 460 V 60 Hz 6P

Rated current : 425 A
 LRC : 6.1
 Rated torque : 1540 ft.lb
 Locked rotor torque : 220 %
 Breakdown torque : 250 %
 Rated speed : 1193 rpm

Moment of inertia (J)
 Duty cycle : Cont.(S1)
 Insulation class : F
 Service factor : 1.15
 Temperature rise : 80 K
 Design : A

Locked rotor time : 52s (cold) 29s (hot)

Rev.	Changes Summary	Performed	Checked	Date
Performed by			Page 3 / 7	Revision
Checked by				
Date	13/04/2022			

LOAD PERFORMANCE CURVE

Three Phase Induction Motor - Squirrel Cage



Customer : _____

Product line : NEMA Premium Efficiency Three-Phase

Product code : 13500652

Catalog # : 35012ET3GKD580Z-W22

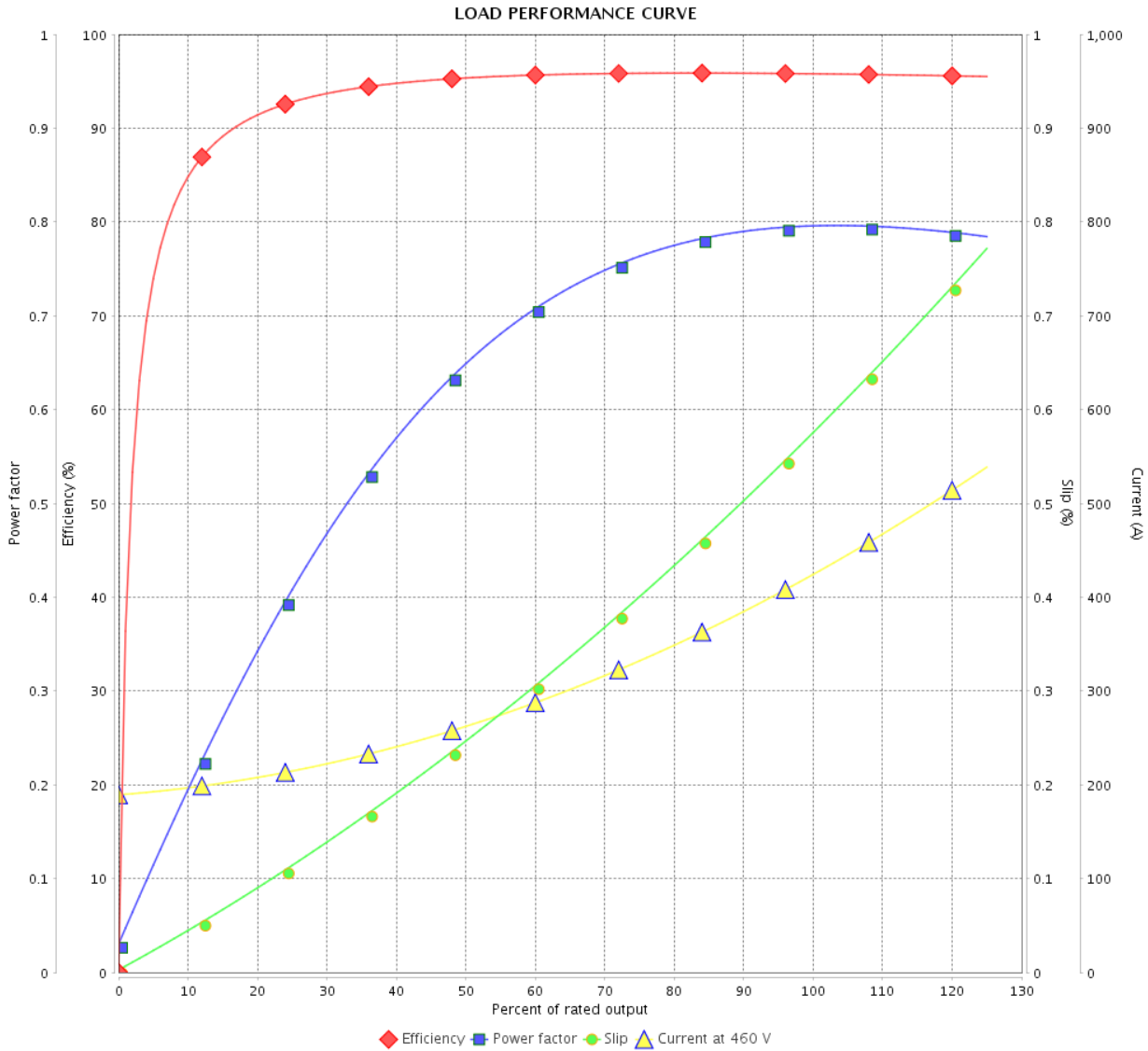

Performance : 460 V 60 Hz 6P

Rated current : 425 A
 LRC : 6.1
 Rated torque : 1540 ft.lb
 Locked rotor torque : 220 %
 Breakdown torque : 250 %
 Rated speed : 1193 rpm

Moment of inertia (J)
 Duty cycle : Cont.(S1)
 Insulation class : F
 Service factor : 1.15
 Temperature rise : 80 K
 Design : A

Rev.	Changes Summary	Performed	Checked	Date
Performed by			Page 4 / 7	Revision
Checked by				
Date	13/04/2022			

THERMAL LIMIT CURVE



Three Phase Induction Motor - Squirrel Cage

Customer :

Product line : NEMA Premium Efficiency Three-Phase
 Product code : 13500652
 Catalog # : 35012ET3GKD580Z-W22

Performance : 460 V 60 Hz 6P

Rated current : 425 A	Moment of inertia (J)
LRC : 6.1	Duty cycle : Cont.(S1)
Rated torque : 1540 ft.lb	Insulation class : F
Locked rotor torque : 220 %	Service factor : 1.15
Breakdown torque : 250 %	Temperature rise : 80 K
Rated speed : 1193 rpm	Design : A

Heating constant

Cooling constant

Rev.	Changes Summary	Performed	Checked	Date
Performed by		Page		Revision
Checked by		5 / 7		
Date	13/04/2022			

THERMAL LIMIT CURVE

Three Phase Induction Motor - Squirrel Cage



Customer : _____

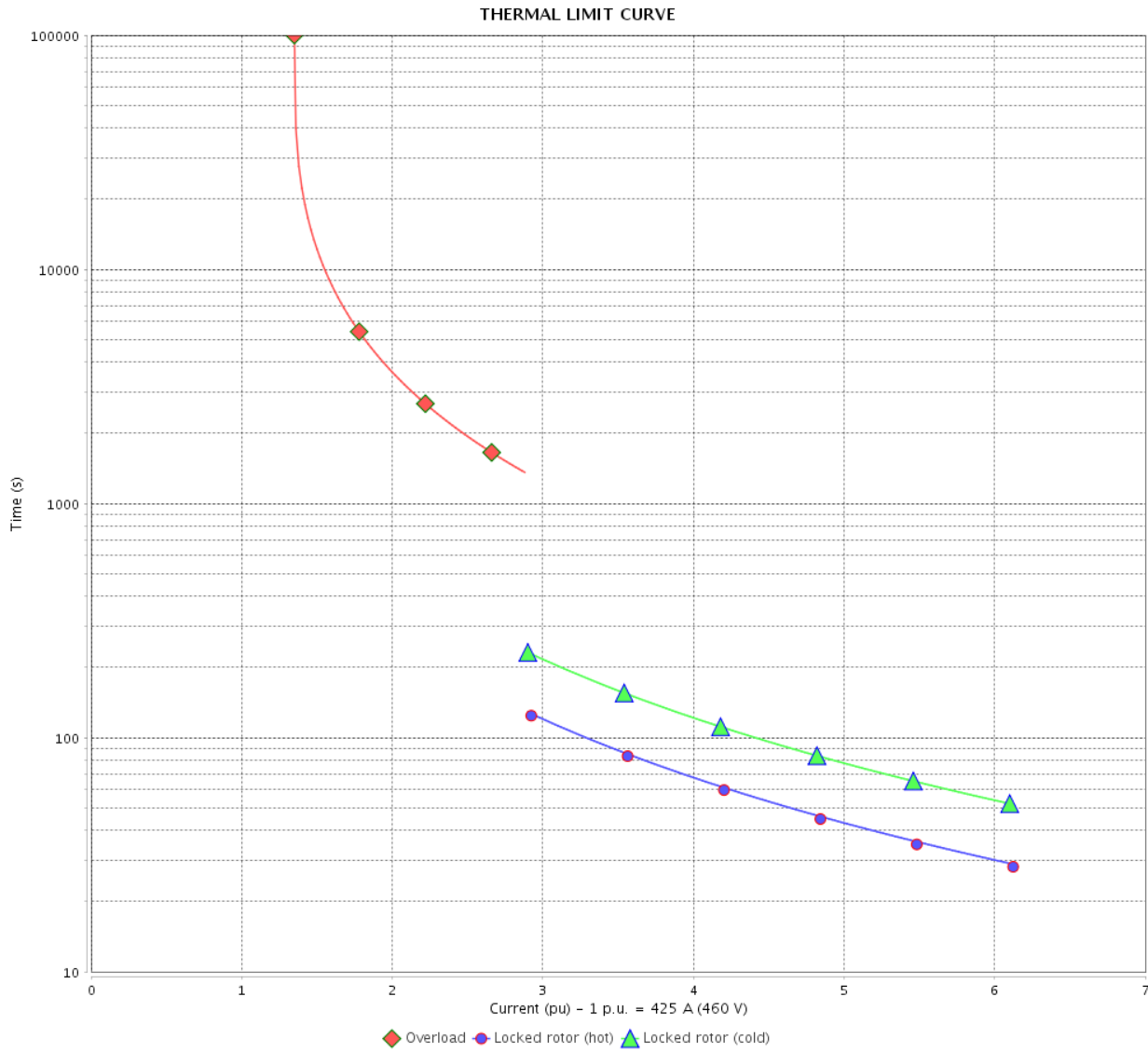

Rev.	Changes Summary	Performed	Checked	Date
Performed by		Page 6 / 7		Revision
Checked by				
Date				

VFD OPERATION CURVE

Three Phase Induction Motor - Squirrel Cage



Customer :

Product line : NEMA Premium Efficiency Three-Phase

Product code : 13500652

Catalog # : 35012ET3GKD580Z-W22

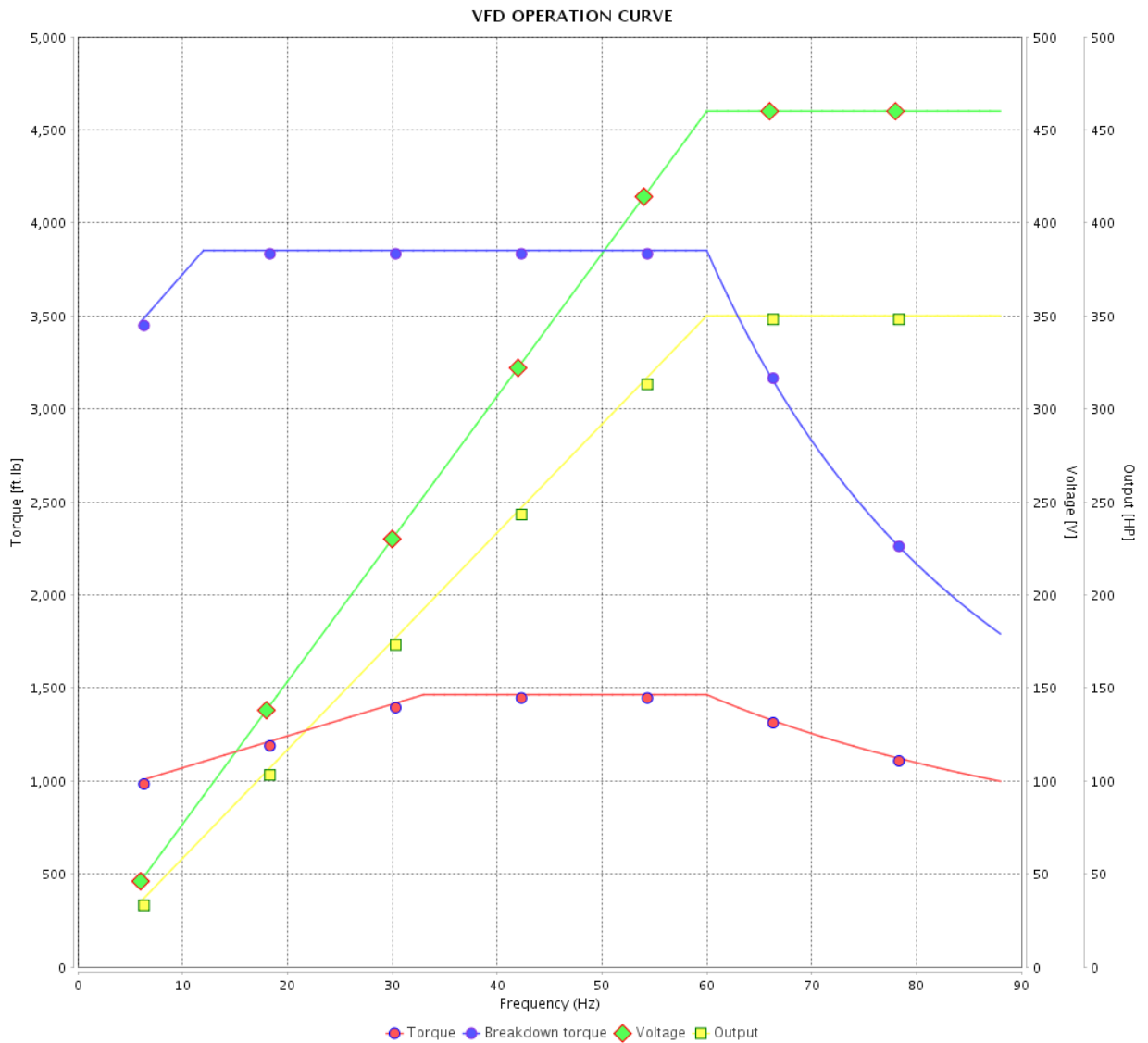

Performance : 460 V 60 Hz 6P

Rated current : 425 A
 LRC : 6.1
 Rated torque : 1540 ft.lb
 Locked rotor torque : 220 %
 Breakdown torque : 250 %
 Rated speed : 1193 rpm

Moment of inertia (J)
 Duty cycle : Cont.(S1)
 Insulation class : F
 Service factor : 1.15
 Temperature rise : 80 K
 Design : A

Rev.	Changes Summary	Performed	Checked	Date
Performed by			Page 7 / 7	Revision
Checked by				
Date	13/04/2022			

EIXO/SHAFT	
PADRÃO/STANDARD	
OPCIONAL/OPTIONAL	
ESPECIAL/SPECIAL	X

Dimensões em polegada
Dimensions in inches

CERTIFIED WEG MOTORES
Certified document.
Not subject to changes.

THIS IS AN UPDATED REVISION, THE PREVIOUS ONE MUST BE DISREGARDED.

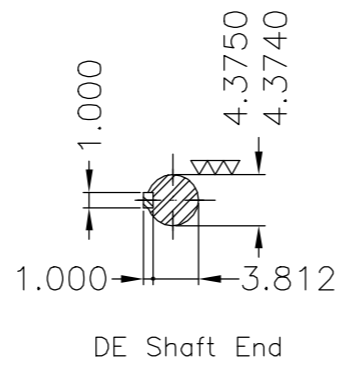
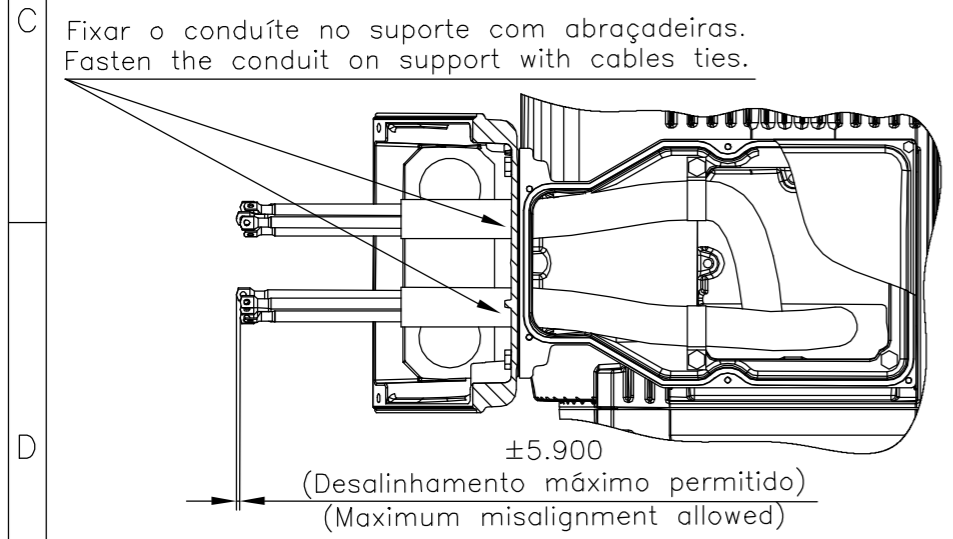
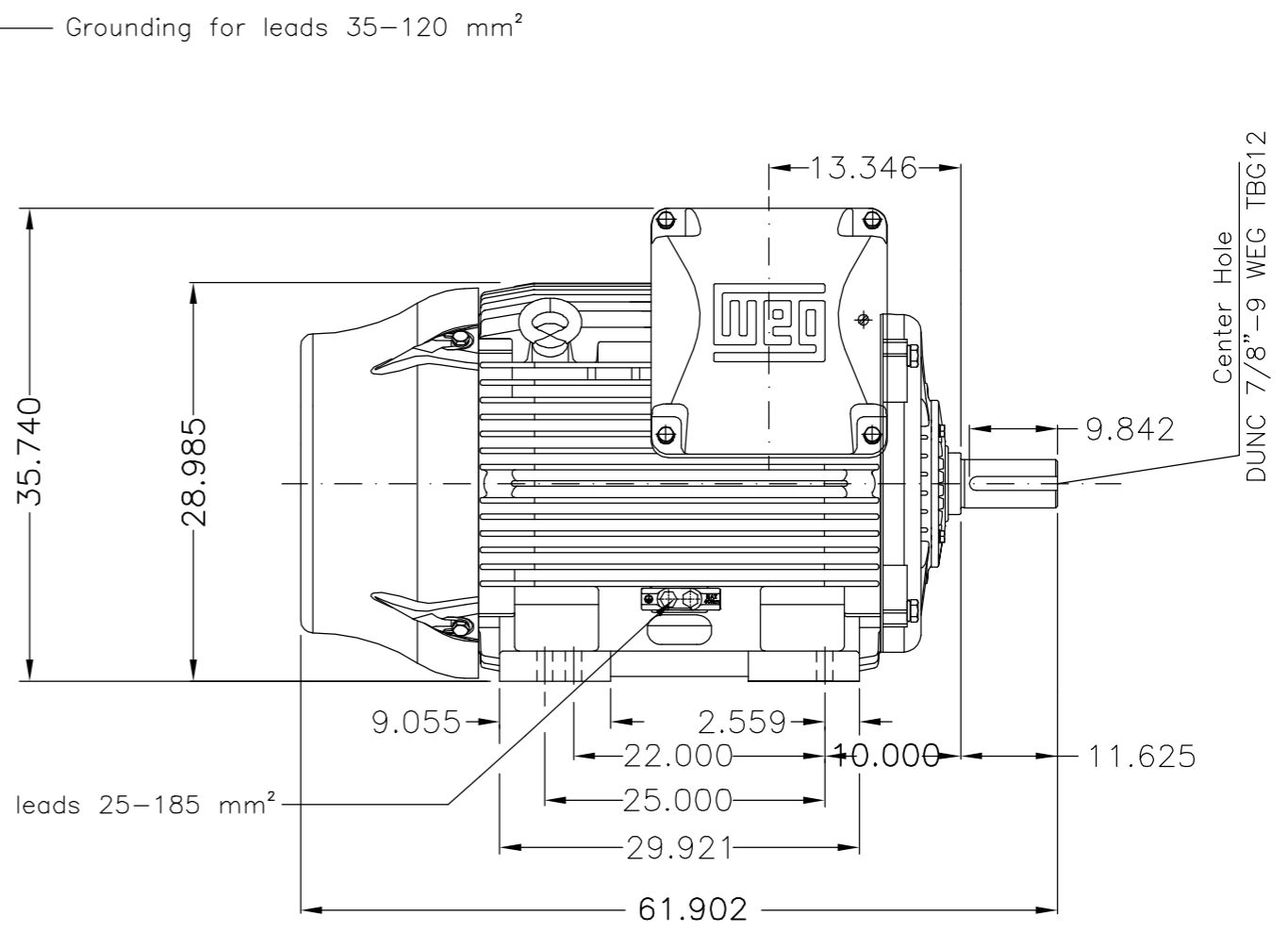
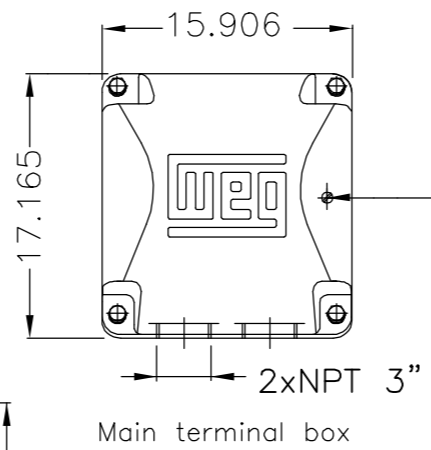
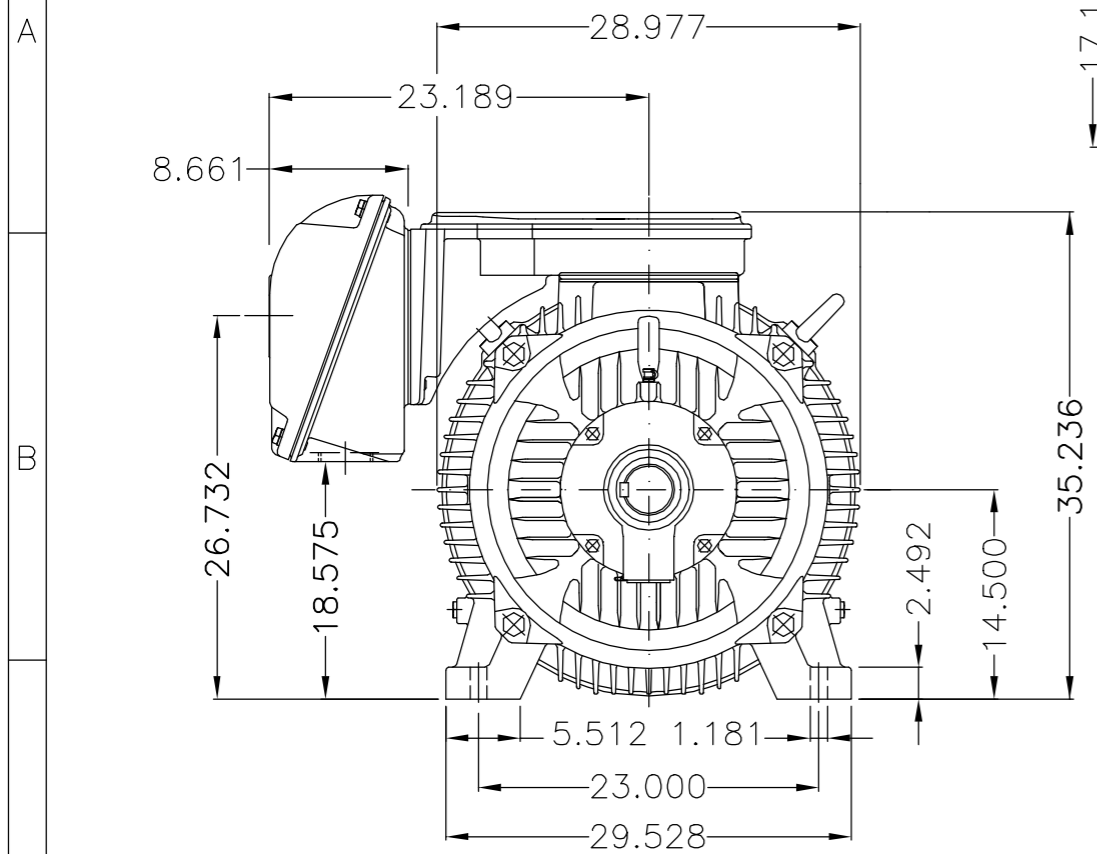

Categoria A / Design A	
Proteção térmica desligamento - termostato 155°C / Thermostats 155°C to trip	
Tampa dianteira especial / Special DE endshield	
Conduite para cabos no interior do suporte da caixa de ligação Cables conduit inside terminal box support	
Linha do motor: Crusher Duty / Motor purpose: Crusher Duty	
Rolamento dianteiro de rolos / DE roller bearing	
Rolamento dianteiro de rolos NU-324 / NU-324 DE roller bearing	
Dispositivo de travamento de eixo / Shaft locking device	
Tampa traseira com mancal eletricamente isolado NDE endshield with electrically insulated bearing hub	
Cor RAL 5009 / Color RAL 5009	
Plano de pintura 203A / Painting plan 203A	
Forma construtiva NEMA F-1 / Mounting NEMA F-1	
Forma construtiva B3D / Mounting B3R(D)	

WEG ELECTRIC CORPORATION - WEC

500 HP	04 Poles	60Hz	J
500 HP	06 Poles	60Hz	I
450 HP	04 Poles	60Hz	H
450 HP	06 Poles	60Hz	G
400 HP	04 Poles	60Hz	F
400 HP	06 Poles	60Hz	E
350 HP	04 Poles	60Hz	D
350 HP	06 Poles	60Hz	C
300 HP	04 Poles	60Hz	B
300 HP	06 Poles	60Hz	A

500001331189	ADIC.NOTA CONDUITE/ADD NOTE CONDUIT	MENSOR	EANJOS	05.07.2017	05			
500001331411	ADIC. NOTA CONDUITE / ADD NOTE CONDUIT	JOSIELS	JMANENTE	04.07.2017	04			
ECM	LOC	SUMMARY OF MODIFICATIONS		EXECUTED	CHECKED	RELEASED	DATE	VER
EXECUTED	DVEGINI	THREE PHASE W22 MOTOR - NEMA PREMIUM EFF		10004040391				
CHECKED		FRAME 586/7TZ IP55		000 05				
RELEASED	NSCHMIDT							
REL DT	25.01.2016	WMO	Jaraguá do Sul	Product Engineering	SHEET	1 / 1		



UNCONTROLLED COPY

RELEASED

ZME A3

MADE IN BRAZIL
13500652



MODEL 35012ET3GKD580Z-W22



FOR SAFE AREA
Mod.TE1BFOXON
CC029A



Class I, Div 2, Gr A, B, C and D - T3
Class I, Zone 2, IIC - T3
Class II, Div 2, Gr F and G - T3C
For use on PWM: Gr. A, B, C and D,
VT 1000:1, CT 6:1, 1.00SF - T2B

Inverter Duty Motor
Severe Duty

PH3 60Hz Fr. 586/7TZ 1000m.a.s.l. IP55 TEFC 4101lb

V 460

A 425

HP 350

kW 260

SF 1.15

SFA 489

RPM 1193

PF 0.80

AMB 40°C

INS cl. F DT80K

NEMA NOM EFF 95.8%

DUTY CONT.

DES A Code G

PART-WINDING

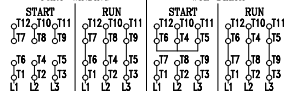

→ NU-324-C3 (72g)

→ 6319-C3 (45g)



MOBIL POLYREX EM (6000h)

