

DATA SHEET

Three Phase Induction Motor - Squirrel Cage



Customer : _____

Space heater information

Voltage: 200 - 240 V

Rev.	Changes Summary	Performed	Checked	Date
Performed by				
Checked by			Page	Revision
Date	13/04/2022		2 / 7	

TORQUE AND CURRENT VS SPEED CURVE



Three Phase Induction Motor - Squirrel Cage

Customer :

Product line : NEMA Premium Efficiency Three-Phase

Product code : 14334997

Catalog # : 40009ET3G588/9-W22

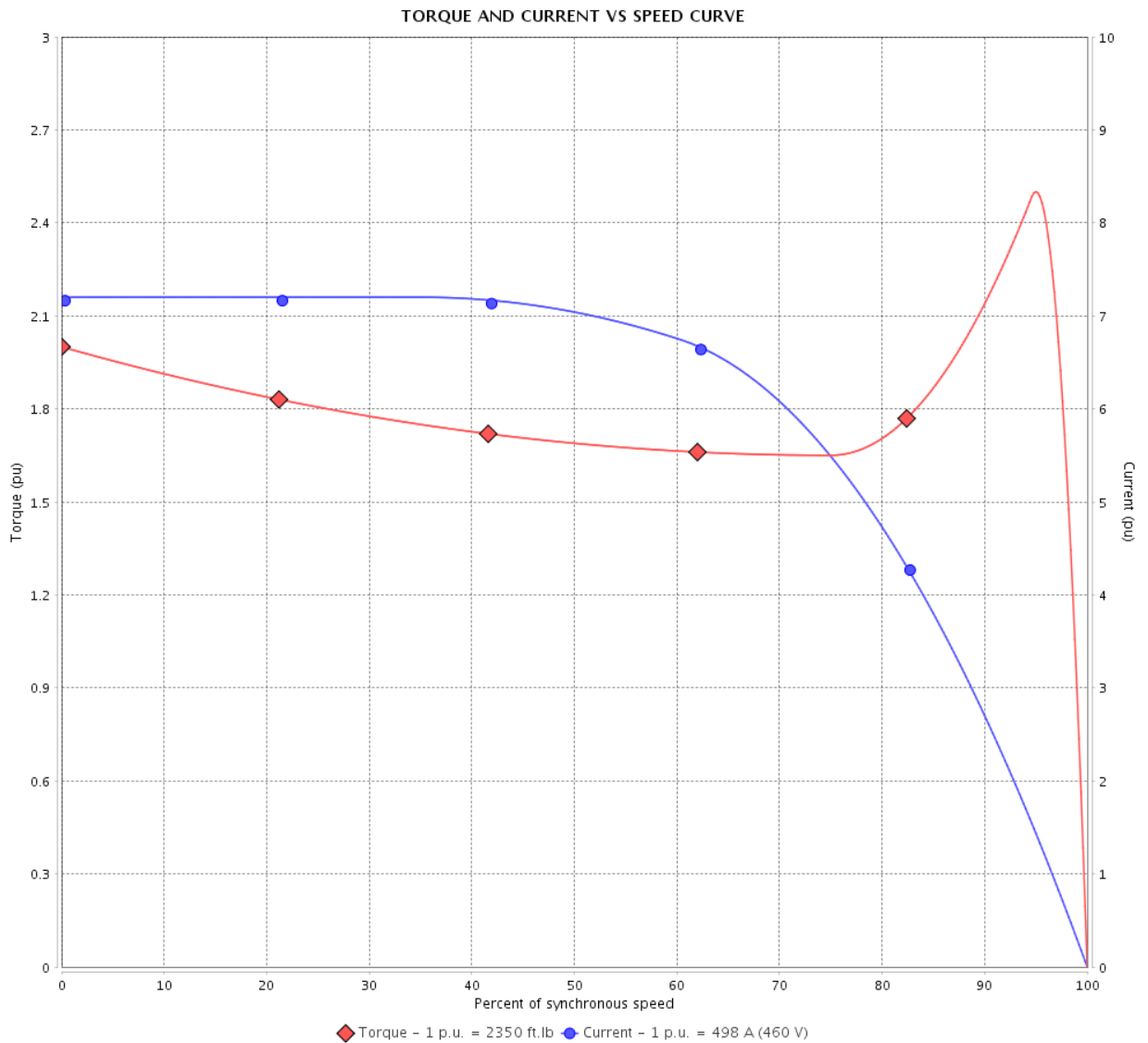

Performance : 460 V 60 Hz 8P

Rated current	: 498 A	Moment of inertia (J)	: 537 sq.ft.lb
LRC	: 7.2	Duty cycle	: Cont.(S1)
Rated torque	: 2350 ft.lb	Insulation class	: F
Locked rotor torque	: 200 %	Service factor	: 1.00
Breakdown torque	: 250 %	Temperature rise	: 80 K
Rated speed	: 894 rpm		

Locked rotor time : 45s (cold) 25s (hot)

Rev.	Changes Summary	Performed	Checked	Date
Performed by			Page 3 / 7	Revision
Checked by				
Date	13/04/2022			

LOAD PERFORMANCE CURVE

Three Phase Induction Motor - Squirrel Cage



Customer :

Product line : NEMA Premium Efficiency Three-Phase

Product code : 14334997

Catalog # : 40009ET3G588/9-W22

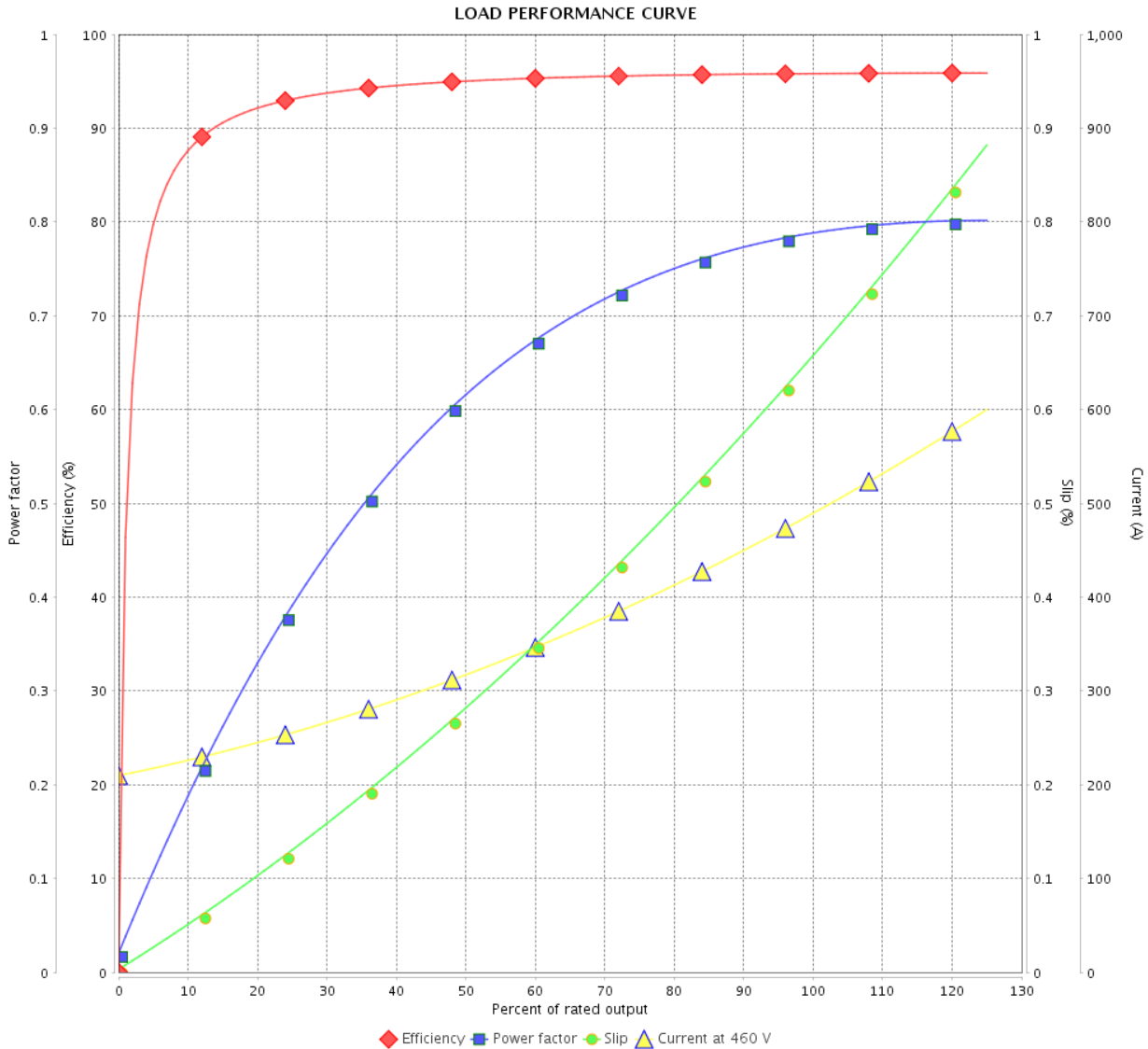

Performance : 460 V 60 Hz 8P

Rated current : 498 A
 LRC : 7.2
 Rated torque : 2350 ft.lb
 Locked rotor torque : 200 %
 Breakdown torque : 250 %
 Rated speed : 894 rpm

Moment of inertia (J) : 537 sq.ft.lb
 Duty cycle : Cont.(S1)
 Insulation class : F
 Service factor : 1.00
 Temperature rise : 80 K

Rev.	Changes Summary	Performed	Checked	Date
Performed by		Page		Revision
Checked by		4 / 7		
Date	13/04/2022			

THERMAL LIMIT CURVE



Three Phase Induction Motor - Squirrel Cage

Customer :

Product line : NEMA Premium Efficiency Three-Phase
 Product code : 14334997
 Catalog # : 40009ET3G588/9-W22

Performance : 460 V 60 Hz 8P

Rated current : 498 A	Moment of inertia (J) : 537 sq.ft.lb
LRC : 7.2	Duty cycle : Cont.(S1)
Rated torque : 2350 ft.lb	Insulation class : F
Locked rotor torque : 200 %	Service factor : 1.00
Breakdown torque : 250 %	Temperature rise : 80 K
Rated speed : 894 rpm	

Heating constant

Cooling constant

Rev.	Changes Summary	Performed	Checked	Date
Performed by			Page 5 / 7	Revision
Checked by				
Date	13/04/2022			

THERMAL LIMIT CURVE

Three Phase Induction Motor - Squirrel Cage



Customer : _____

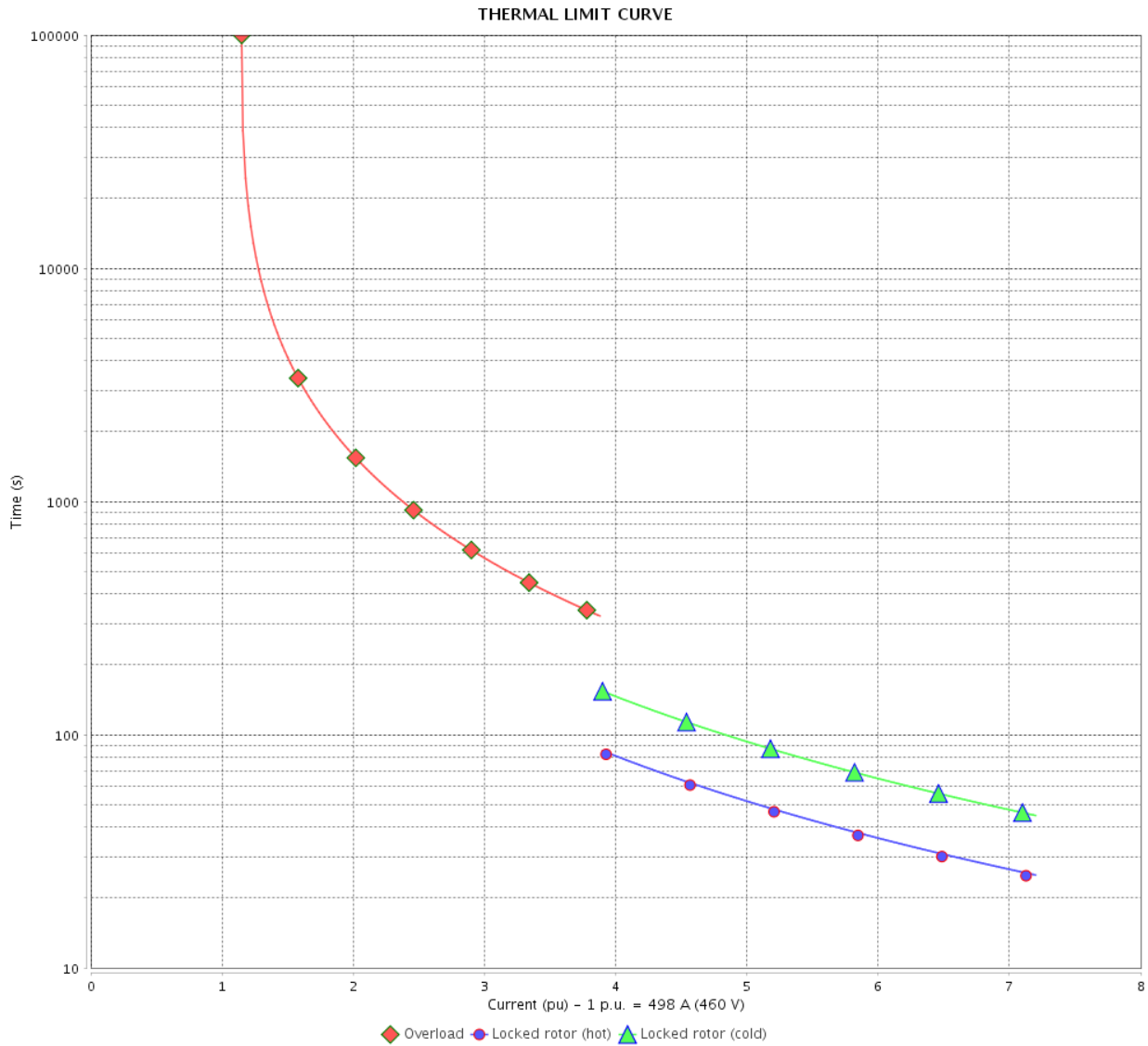

Rev.	Changes Summary	Performed	Checked	Date
Performed by		Page 6 / 7		Revision
Checked by				
Date				

VFD OPERATION CURVE

Three Phase Induction Motor - Squirrel Cage



Customer :

Product line : NEMA Premium Efficiency Three-Phase

Product code : 14334997

Catalog # : 40009ET3G588/9-W22

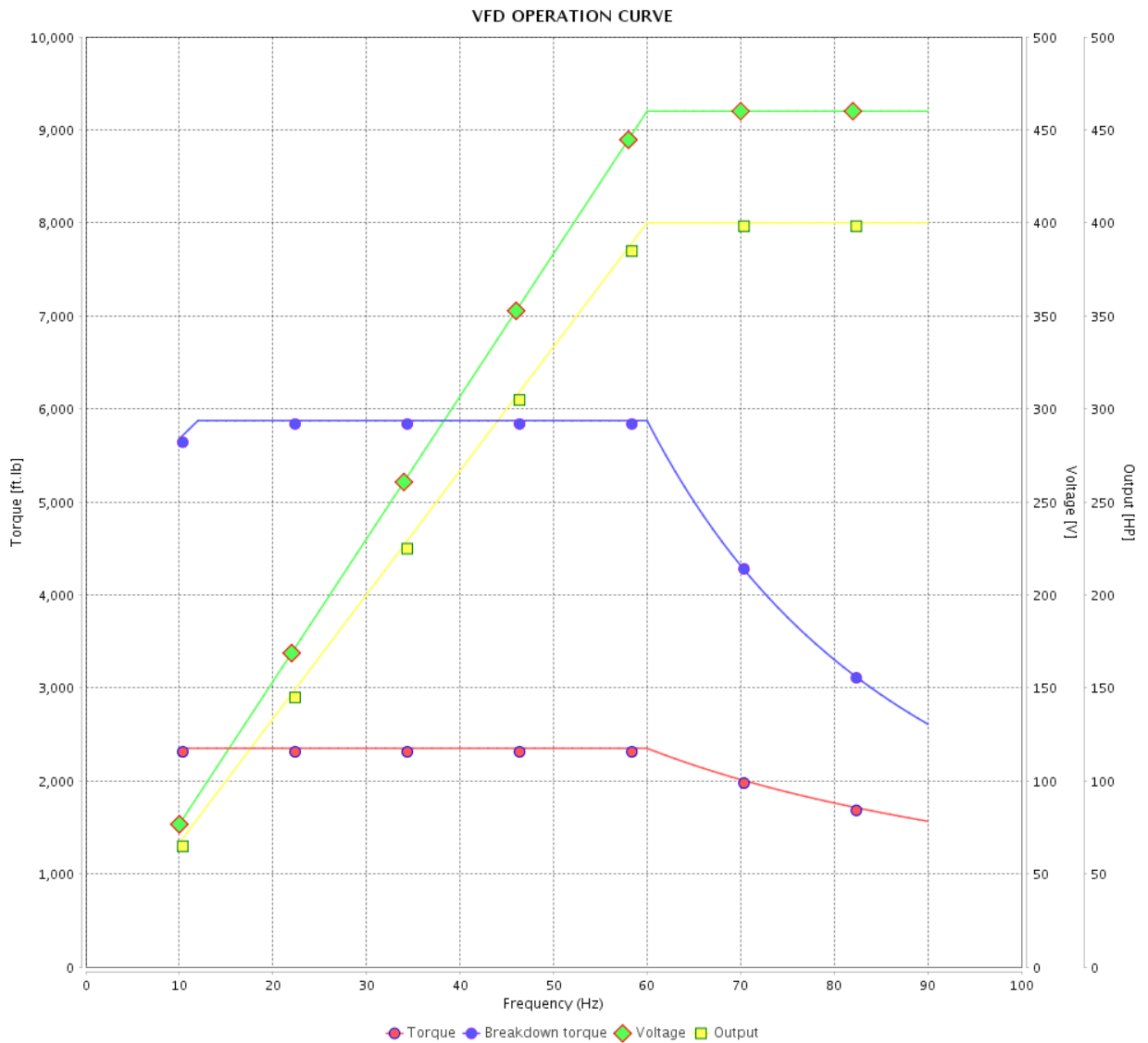

Performance : 460 V 60 Hz 8P

Rated current : 498 A
 LRC : 7.2
 Rated torque : 2350 ft.lb
 Locked rotor torque : 200 %
 Breakdown torque : 250 %
 Rated speed : 894 rpm

Moment of inertia (J) : 537 sq.ft.lb
 Duty cycle : Cont.(S1)
 Insulation class : F
 Service factor : 1.00
 Temperature rise : 80 K

Rev.	Changes Summary	Performed	Checked	Date
Performed by				Page 7 / 7
Checked by				
Date	13/04/2022			

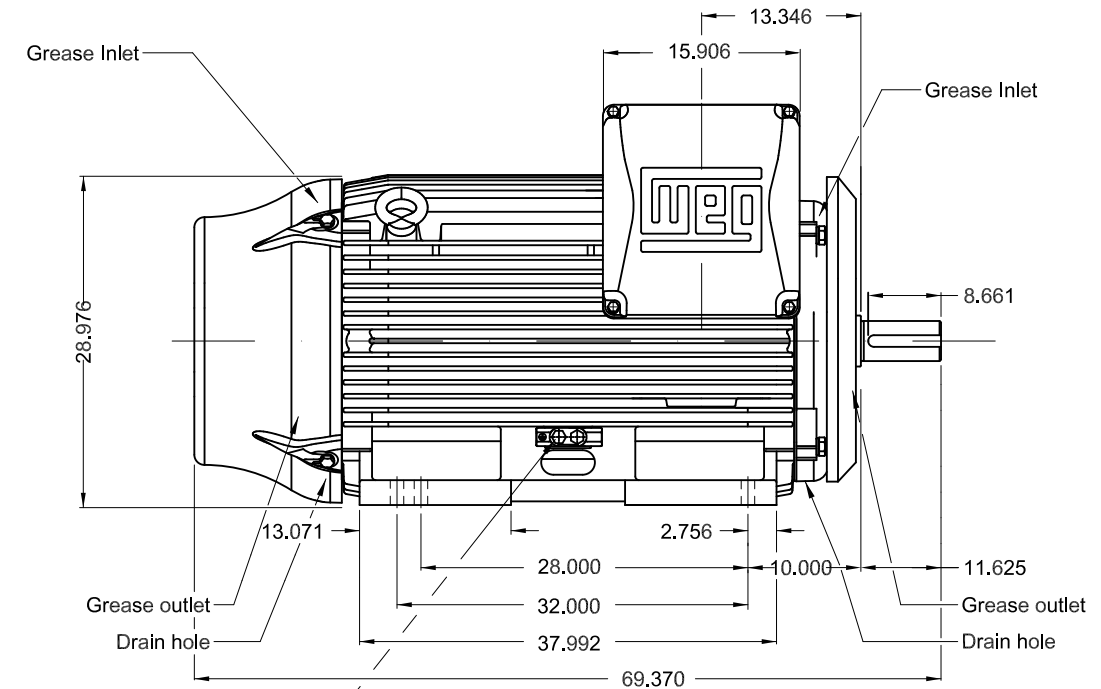
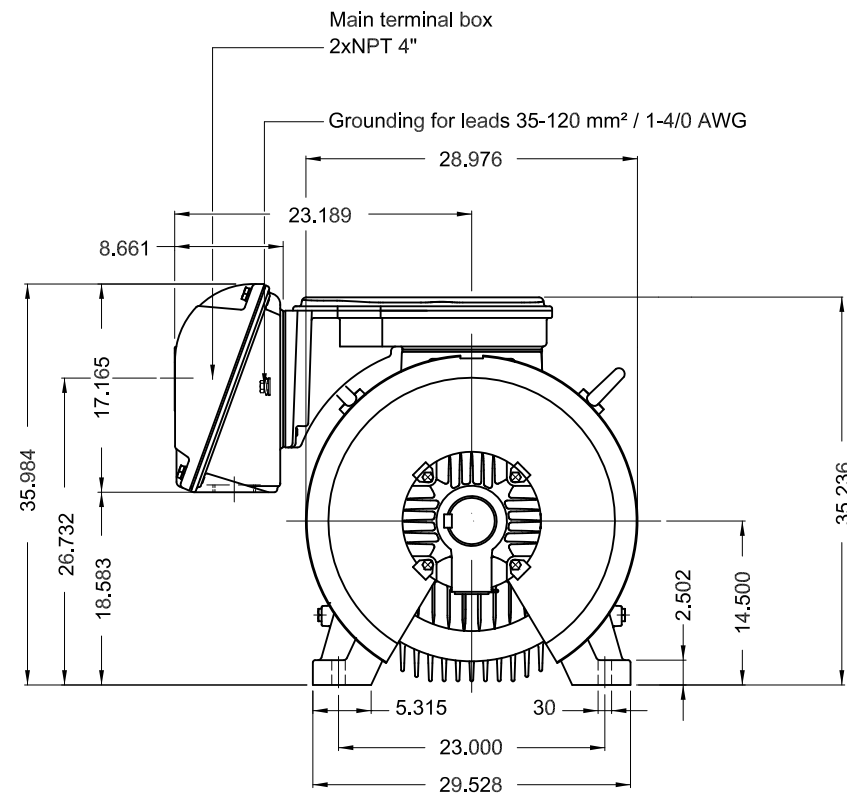

Grounding for leads 25-185 mm² / 3AWG-350MCM

400 HP 08 Poles 60 Hz

Dimensions in inches

- E NDE endshield with electrically insulated bearing hub
- Drive-End Air Deflector
- Color RAL 5009
- Painting plan 203A
- Mounting NEMA F-1
- Mounting B3R(D)

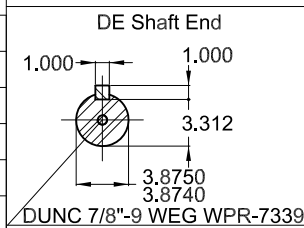

ECM	LOC	SUMMARY OF MODIFICATIONS	EXECUTED	CHECKED	RELEASED	DATE	VER
EXECUTED	PIRWBUSER	THREE PH. MOTOR W22 PREM. EFF.					
CHECKED		FRAME 588/9T IP55 TEFC					
RELEASED							
REL DT.	WMO	Jaragua do Sul	Product Engineering	SHEET	1 / 1		

PREVIEW
WDD





NEMA
Premium
W22



FOR SAFE AREA
Mod.TE1BFOXON



Class I, Div 2, Gr A, B, C and D - T3
Class I, Zone 2, IIC - T3
Class II, Div 2, Gr F and G - T4
For use on PWM: Gr. A, B, C and D,
VT 1000:1, CT 6:1, 1.00SF - T2B

MODEL 40009ET3G588/9-W22

Inverter Duty Motor
Severe Duty

PH3 60Hz Fr. 588/9T 1000m.a.s.l. IP55 TEFC 5243lb

V 460

A 498

HP 400

kW 300

SF 1.00

SFA -

RPM 894

PF 0.79

AMB 40°C

INS cl. F DT80K

NEMA NOM EFF 95.8%

DUTY CONT.

DES - Code J

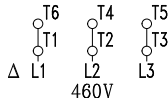

→ 6322-C3 (60g)

→ 6319-C3 (45g)



MOBIL POLYREX EM (11801h)

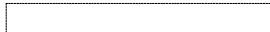

MADE IN BRAZIL
14334997