

TYPE	OUTPUT		POLE	TIME RATING	VOLTAGE V	Hz	SYN SPEED R.P.M
	HP.	KW.					
AEHXXU	100	75	6	CONT.	230/460	60	1200

TOTALLY ENCLOSED FAN-COOLED TYPE, SQUIRREL-CAGE ROTOR

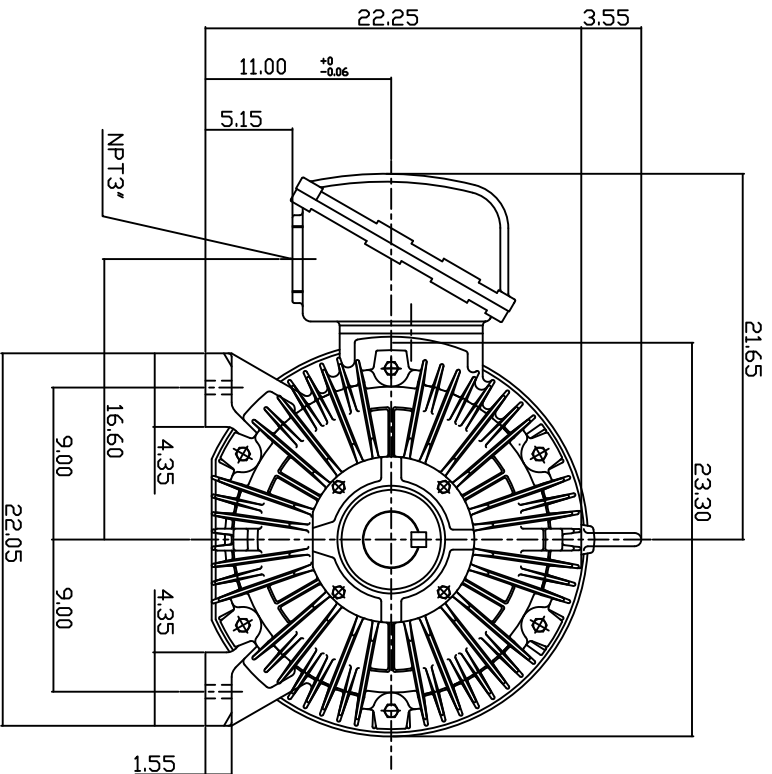
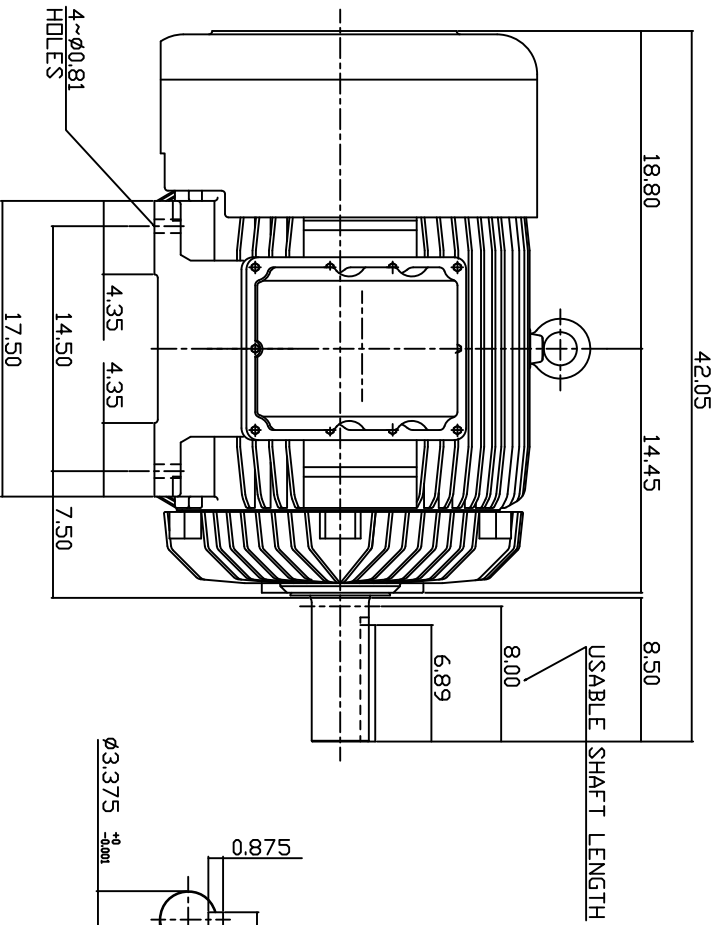

NOTE:

1. DIMENSIONS IN INCH.
2. FRAME NO. 444T
3. F CLASS INSULATION, S.F.1.15
4. UL EXPLOSION PROOF
5. SUITABLE FOR DIVISION I, CLASS I, GROUP D, CLASS II, GROUP E, F, G.
6. BEARING SIZE: DRIVE END: NU318
NON-DRIVE END: 6318
7. MOTOR APPRX. WEIGHT: 1600 LBS

TX-56

DWN.	W.LLIN	APR-07-2003
CHKD.	W.LLIN	APR-07-2003
APPD.	C.WANG	APR-07-2003

DATE
MAY 2, 2004
CATALOG NO.
XP1006R

OUTLINE DIMENSIONS
3-PHASE INDUCTION MOTOR



DWG. NO. 3A040T3270-1
REV: 00

TECO Westinghouse

ISSUED April 6, 2011	PERFORMANCE DATA	ENCLOSURE EXPLOSION PROOF
TYPE AEHHXU	3-PHASE INDUCTION MOTOR	CATALOG# XP1006R

NAMEPLATE INFORMATION

OUTPUT		POLE	FRAME SIZE	VOLTAGE	HZ	RATED AMBIENT	INS. CLASS	NEMA DESIGN	TIME RATING	SERVICE FACTOR
HP	KW									
100	74.6	6	444T	230/460	60	40°C	F	B	CONT.	1.15

TYPICAL PERFORMANCE

FULL LOAD RPM	EFFICIENCY				POWER FACTOR			MAXIMUM POWER FACTOR CORRECTION
	FULL LOAD		3/4 LOAD %	1/2 LOAD %	F. L. %	3/4 LOAD %	1/2 LOAD %	
	MIN. %	NOM. %						
1180	94.1	95	94.5	93.6	83	81	74	38.2 KVAR

CURRENTS

NO LOAD			FULL LOAD			LOCKED ROTOR			NEMA KVA CODE LETTER
AT	AT	AT	AT	AT	AT	AT	AT	AT	
208 VOLT	230 VOLT	460 VOLT	208 VOLT	230 VOLT	460 VOLT	208 VOLT	230 VOLT	460 VOLT	
106.15	96.00	48.00	260.96	236.00	118.00	1603.37	1450.00	725.00	G

TORQUE

INERTIA

ACCEL TIME

FULL LOAD lb-ft	LOCKED ROTOR %FLT	PULL UP %FLT	BREAK DOWN %FLT	ROTOR WR ² lb-ft ²	NEMA LOAD WK ² lb-ft ²	MAX ALLOWABLE WK ² lb-ft ²	NEMA LOAD WK ² Sec	MAX ALLOWABLE WK ² Sec
445	130	104	210	50	1181	2812.00	6.42	14.93

SAFE STALL TIME IN SECONDS

ALLOWABLE STARTS PER HOUR

SOUND PRESSURE LEVEL @ 3 FT dB(A)

COLD	HOT	COLD	HOT	80
37	15	2	1	

APPROVED:	M. PRATER	DRAWING NO.	3A057XP1006R	REVISION 0
-----------	------------------	-------------	---------------------	-------------------

DATE:
May 14, 2011

CONNECTION DIAGRAM

CATALOG NO.:
XP1006R



SCHEMATIC - Δ / Y CONNECTION

ACROSS THE LINE CONNECTION



LINE
230 VOLT CONNECTION



LINE
460 VOLT CONNECTION

***CONTACT TWMC IF YOU HAVE ANY QUESTIONS
REGARDING THE MOTOR CONNECTION.**

PH: 1-800-873-8326