

TYPE	OUTPUT		POLE	TIME RATING	VOLTAGE V	Hz	SYN.SPEED R.P.M
	HP.	kW.					
AEHHXU	125	93	4	CONT.	230/460	60	1800

TOTALLY ENCLOSED FAN-COOLED TYPE, SQUIRREL-CAGE ROTOR

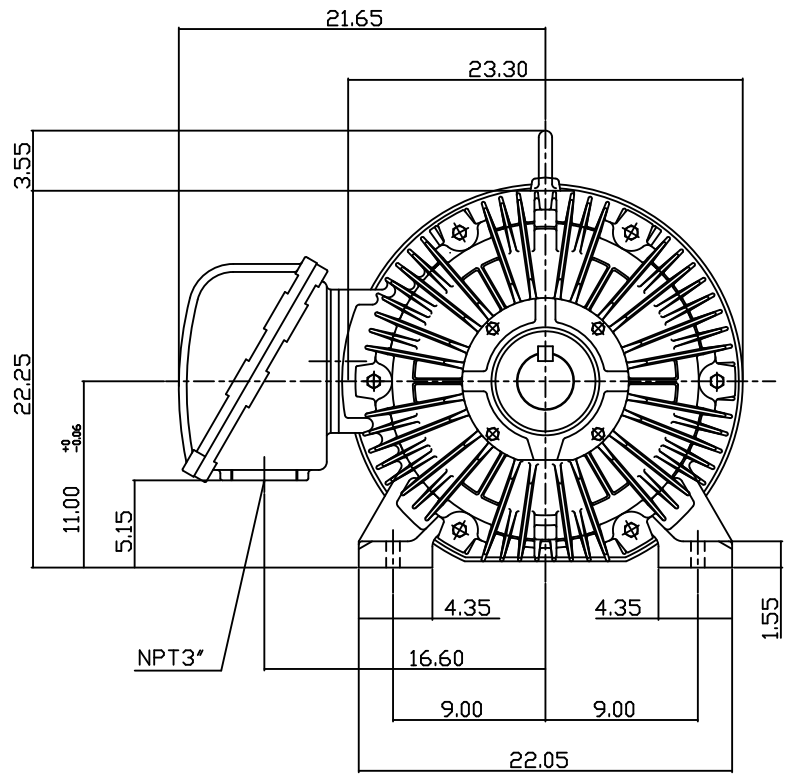
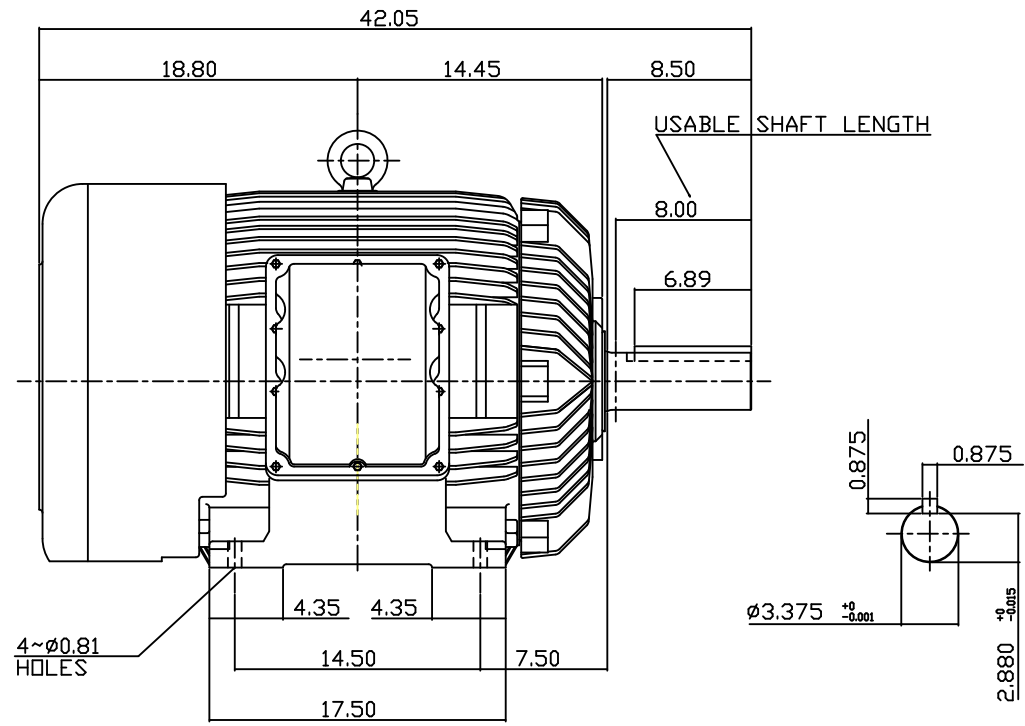

- NOTE:
1. DIMENSIONS IN INCH.
  2. FRAME NO. 444T
  3. F CLASS INSULATION, S.F.1.15
  4. UL EXPLOSION PROOF
  5. SUITABLE FOR DIVISION I, CLASS I, GROUP D, CLASS II, GROUP E,F,G.
  6. BEARING SIZE: DRIVE END: 6318  
NON-DRIVE END: 6318
  7. MOTOR APPROX. WEIGHT: 1600 LBS

TX-56

DWN.	W.L.LIN	APR-07-2003
CHKD.	W.L.LIN	APR-07-2003
APPD.	C.WANG	APR-07-2003

DATE  
AUG. 30, 2011  
CATALOG NO.  
XP1254

OUTLINE DIMENSIONS  
3-PHASE INDUCTION MOTOR

TECO Westinghouse

DWG NO. REV: 00  
3A040T3271-1

# TECO Westinghouse

ISSUED <b>April 6, 2011</b>	<b>PERFORMANCE DATA</b> <b>3-PHASE INDUCTION MOTOR</b>	ENCLOSURE <b>EXPLOSION PROOF</b>
TYPE <b>AEHHXU</b>		CATALOG# <b>XP1254</b>

### NAMEPLATE INFORMATION

OUTPUT		POLE	FRAME SIZE	VOLTAGE	HZ	RATED AMBIENT	INS. CLASS	NEMA DESIGN	TIME RATING	SERVICE FACTOR
HP	KW									
<b>125</b>	<b>93.3</b>	<b>4</b>	<b>444T</b>	<b>230/460</b>	<b>60</b>	<b>40°C</b>	<b>F</b>	<b>B</b>	<b>CONT.</b>	<b>1.15</b>

### TYPICAL PERFORMANCE

FULL LOAD RPM	EFFICIENCY				POWER FACTOR			MAXIMUM POWER FACTOR CORRECTION
	FULL LOAD		3/4 LOAD	1/2 LOAD	F. L.	3/4 LOAD	1/2 LOAD	
	MIN. %	NOM. %						
<b>1780</b>	<b>94.5</b>	<b>95.4</b>	<b>95</b>	<b>94.1</b>	<b>88.5</b>	<b>83</b>	<b>76</b>	<b>30.2 KVAR</b>

### CURRENTS

NO LOAD			FULL LOAD			LOCKED ROTOR			NEMA KVA CODE LETTER
AT	AT	AT	AT	AT	AT	AT	AT	AT	
208 VOLT	230 VOLT	460 VOLT	208 VOLT	230 VOLT	460 VOLT	208 VOLT	230 VOLT	460 VOLT	
<b>83.82</b>	<b>75.80</b>	<b>37.90</b>	<b>305.19</b>	<b>276.00</b>	<b>138.00</b>	<b>2005.87</b>	<b>1815.00</b>	<b>907.00</b>	<b>G</b>

### TORQUE

### INERTIA

### ACCEL TIME

FULL LOAD lb-ft	LOCKED ROTOR %FLT	PULL UP %FLT	BREAK DOWN %FLT	ROTOR WR <sup>2</sup> lb-ft <sup>2</sup>	NEMA LOAD WK <sup>2</sup> lb-ft <sup>2</sup>	MAX ALLOWABLE WK <sup>2</sup> lb-ft <sup>2</sup>	NEMA LOAD WK <sup>2</sup> Sec	MAX ALLOWABLE WK <sup>2</sup> Sec
<b>368</b>	<b>120</b>	<b>96</b>	<b>210</b>	<b>45</b>	<b>542</b>	<b>1015.00</b>	<b>5.70</b>	<b>10.30</b>

SAFE STALL TIME IN SECONDS

ALLOWABLE STARTS PER HOUR

SOUND PRESSURE LEVEL @ 3 FT dB(A)

COLD	HOT	COLD	HOT	
<b>34</b>	<b>12</b>	<b>2</b>	<b>1</b>	

APPROVED:	<b>M. PRATER</b>	DRAWING NO.	<b>3A057XP1254</b>	REVISION <b>0</b>
-----------	------------------	-------------	--------------------	-------------------

DATE:  
May 14, 2011

# CONNECTION DIAGRAM

CATALOG NO.:  
XP1254



**SCHEMATIC -  $\Delta$  / Y CONNECTION**

## ACROSS THE LINE CONNECTION



**LINE  
230 VOLT CONNECTION**



**LINE  
460 VOLT CONNECTION**

**\*CONTACT TWMC IF YOU HAVE ANY QUESTIONS  
REGARDING THE MOTOR CONNECTION.**

**PH: 1-800-873-8326**