

BALDOR® • RELIANCE 

Product Information Packet

XT3022T

2HP,3450RPM,3PH,60HZ,145T,0532M,TEFC,F1

Part Detail							
Revision:	-	Status:	PRD/A	Change #:		Proprietary:	No
Type:	AC	Elec. Spec:	05WGW115	CD Diagram:	CD0005	Mfg Plant:	
Mech. Spec:		Layout:	05LY-000-377	Poles:	02	Created Date:	11-20-2020
Base:		Eff. Date:	12-15-2020	Leads:	9#18		

Specs			
Catalog Number:	XT3022T	Electrically Isolated Bearing:	Not Electrically Isolated
Enclosure:	TEFC	Feedback Device:	NO FEEDBACK
Frame:	145T	Heater Indicator:	No Heater
Frame Material:	Iron	Insulation Class:	F
Output @ Frequency:	2.000 HP @ 60 HZ	Inverter Code:	Inverter Duty
Synchronous Speed @ Frequency:	3600 RPM @ 60 HZ	IP Rating:	NONE
Voltage @ Frequency:	460.0 V @ 60 HZ	KVA Code:	N
	230.0 V @ 60 HZ	Lifting Lugs:	No Lifting Lugs
	208.0 V @ 60 HZ	Locked Bearing Indicator:	No Locked Bearing
XP Class and Group:	CLI GP A,B,C,D	Motor Lead Termination:	Flying Leads
XP Division:	Division II	Motor Type:	0532M
Agency Approvals:	CCSA US	Mounting Arrangement:	F1
	CSA EEV	Power Factor:	85
	NEMA PREMIUM	Product Family:	General Purpose
	UR	Pulley Face Code:	Standard
Auxillary Box:	No Auxillary Box	Rodent Screen:	None
Auxillary Box Lead Termination:	None	Shaft Ground Indicator:	No Shaft Grounding
Base Indicator:	Rigid	Shaft Rotation:	Reversible

Bearing Grease Type:	Polyrex EM (-20F +300F)	Speed Code:	Single Speed
Blower:	None	Motor Standards:	NEMA
Constant Torque Speed Range:	6	Starting Method:	Direct on line
Current @ Voltage:	5.400 A @ 208.0 V	Thermal Device - Bearing:	None
	5.000 A @ 230.0 V	Thermal Device - Winding:	None
	2.500 A @ 460.0 V	Vibration Sensor Indicator:	No Vibration Sensor
Design Code:	B	Winding Thermal 1:	None
Drip Cover:	No Drip Cover	Winding Thermal 2:	None
Duty Rating:	CONT	XP Temp Code:	T4

Nameplate NP4163L											
CAT.NO.	XT3022T						I.P.	54			
SPEC.	05-0000-0901						ENCL	TEFC			
FRAME	145T				H.P.	2					
VOLTS	208-230/460				P.F.	85					
F.L. AMPS	5.4-5/2.5				RATING	40C AMB-CONT					
R.P.M.	3450				USABLE AT 208V						
HZ.	60				PH.	3		CLASS	F		
SER.F.	1.15				DES.	B		SL HZ	1.7		
NEMA NOM. EFF.	86.5				Wk2	0.09		ODE	6203		
DE	6205				TO	90		T. CODE	T4		
MAG. CUR.	2.2/1.1				CT	6		TO	60		
INV TYPE	PWM		CHP 60		VT	6		TO	60		
CC	010A		SN								
	USABLE AT 50 HZ 1.5HP 190/380V										
	4.8/2.4A										

Parts List		
Part Number	Description	Quantity
SA388538	SA 05-0000-0901	1.000 EA
RA378903	RA 05-0000-0901	1.000 EA
LB1115N	LABEL,LIFTING DEVICE (ON ROLLS)	1.000 EA
LC0005E01	CONN.DIA./WARNING LABEL (LC0005/LB1119N)	1.000 EA
LB1449	DIV-2/NEC WARNING LABEL	1.000 EA
NP4163L	SS CP INV DIV-2 UL CSA-C US EEV PREM, DI	1.000 EA
85XU0407S04	4X1/4 U DRIVE PIN STAINLESS	2.000 EA
MN416A01	TAG-INSTAL-MAINT no wire (2100/bx) 4/22	1.000 EA
HW3201A05	3/8-16 EYEBOLT	1.000 EA
35FH4005A32SP	IEC FH NO GRSR W/3 HOLES - PRIMED	1.000 EA
51XW1032A06	10-32 X .38, TAPTITE II, HEX WSHR SLTD S	3.000 EA
34FN3002B01	EXTERNAL FAN, PLASTIC, .637/.639 HUB W/	1.000 EA
51XB0818A12	8-18X3/4 HXWSSLD SERTYB	1.000 EA
MJ1000A02	GREASE, MOBIL POLYREX EM - 124047	0.050 LB
HA3100A37	THRUBOLT 10-32 X 8.500	4.000 EA
XY1032A02	10-32 HEX NUT DIRECTIONAL SERRATION	4.000 EA
35EP3122K00	MASTER ODE,203 BRG,.683SH,#26 DRN,FH MTG	1.000 EA
HW4600B39SP	V-RING SLINGER 0.550 X 0.790 X .18 VITON	1.000 EA
HW5100A03	WAVY WASHER (W1543-017)	1.000 EA
HA4067A01	PUSH IN DRAIN FITTING (BLACK)	1.000 EA
35EP3123A00	MASTER DE,205 BRG,.998SH,#26 DRN	1.000 EA
HW4600B32SP	V-RING SLINGER 1.000 X 1.540 X .24 VITON	1.000 EA
HA4067A01	PUSH IN DRAIN FITTING (BLACK)	1.000 EA
06CB3000	BALDOR CONDUIT BOX CAST	1.000 EA

Parts List (continued)		
Part Number	Description	Quantity
06GS1000	GASKET,CONDUIT BOX	1.000 EA
51XW2520A12	SCREW, HEX SER SLT HD, ZN, 1/4-20 X .75	2.000 EA
11XW1032G06	10-32 X .38, TAPTITE II, HEX WSHR SLTD U	1.000 EA
HW3001B02	BRASS CUP WASHER W/GROUND SYMBOL TAB,	1.000 EA
06CB3500	BALDOR CONDUIT BOX LID	1.000 EA
06GS1001	BALDOR CONDUIT BOX GASKET	1.000 EA
51XW2520A12	.25-20 X .75, TAPTITE II, HEX WSHR SLTD	2.000 EA
MG1025L14	WILKOFAS, 776.14, GRUNDFOS BLACK	0.125 GA
36PA1000	PKG GRP, PRINT PK1016A06	1.000 EA
HW2501D13	KEY, 3/16 SQ X 1.375	1.000 EA
HA7000A01	KEY RETAINER 7/8" DIA SHAFT	1.000 EA
FE-0000001	ZRTG FE ASSEMBLY	1.000 EA
PE-0000001	ZRTG PE ASSEMBLY	1.000 EA

AC Induction Motor Performance Data

Record # 84572

Typical performance - not guaranteed values

Winding: 05WGW115-R032		Type: 0532M		Enclosure: TEFC	
Nameplate Data			460 V, 60 Hz: High Voltage Connection		
Rated Output (HP)	2	Full Load Torque	3 LB-FT		
Volts	208-230/460	Start Configuration	direct on line		
Full Load Amps	5.4-5/2.5	Breakdown Torque	16 LB-FT		
R.P.M.	3450	Pull-up Torque	12.5 LB-FT		
Hz	60 Phase	3	Locked-rotor Torque	16 LB-FT	
NEMA Design Code	B KVA Code	N	Starting Current	30 A	
Service Factor (S.F.)		1	No-load Current	1.1 A	
NEMA Nom. Eff.	86.5 Power Factor	85	Line-line Res. @ 25°C	5.4 Ω	
Rating - Duty	40C AMB-CONT		Temp. Rise @ Rated Load	31°C	
			Rotor inertia	0.0885 lb-ft ²	

Load Characteristics 460 V, 60 Hz, 2 HP

% of Rated Load	25	50	75	100
Power Factor	50	70	80	85
Efficiency	75.2	83.8	86.2	86.5
Speed	3571	3548	3525	3501
Line amperes	1.28	1.65	2.09	2.55

Performance Graph at 460V, 60Hz, 2.0HP Typical performance - Not guaranteed values

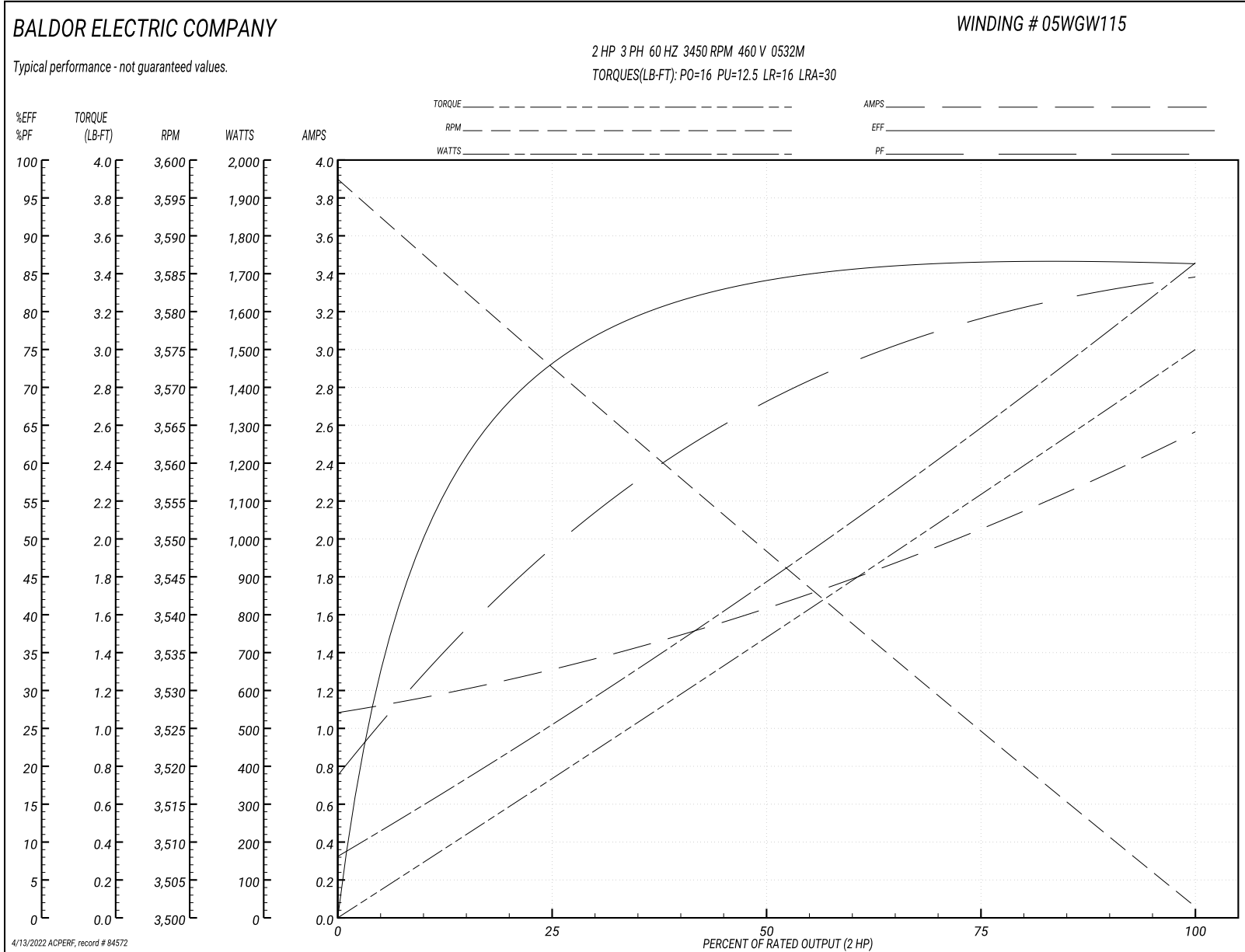

05LY-000-377

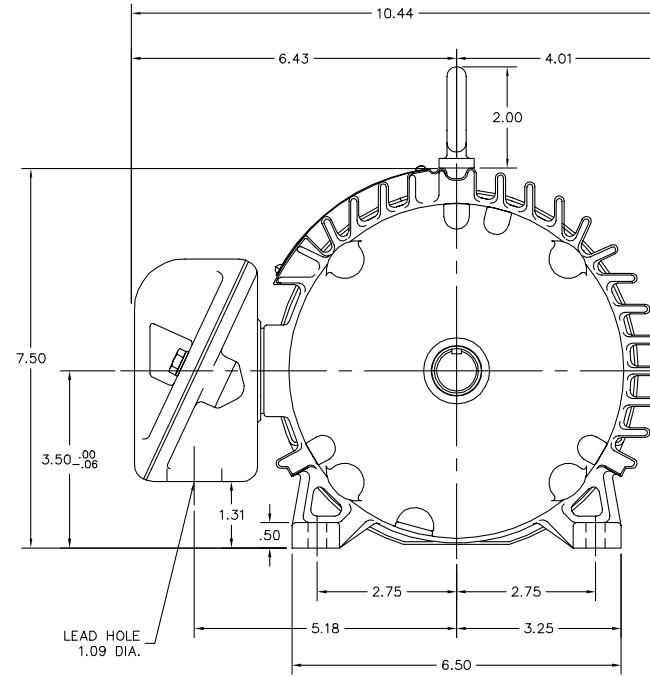
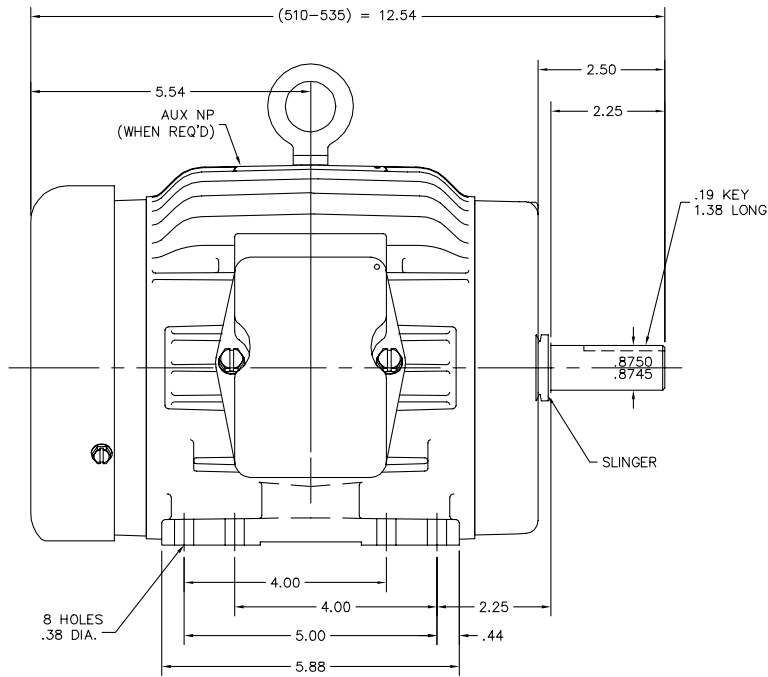

CUSTOMER IS RESPONSIBLE FOR DETERMINING THAT THE PRODUCT WILL PERFORM SUITABLY IN THE INTENDED APPLICATION.

REV. DESC: NEW	VERSION: 00	TDR: 000001146643
REV. LTR: -	REVISED: 01:59:08 09/09/2020	BY: ENROBRO
FILE: \AAA\00255\663		
MTL: -		

BALDOR - RELIANCE[®]
 HORZ TEFC 143-5T 305M W/SEALED BRGS
 SH 1 of 1

05LY-000-377

CD0005



LOW VOLTAGE
(2Y)



LINE

HIGH VOLTAGE
(1Y)

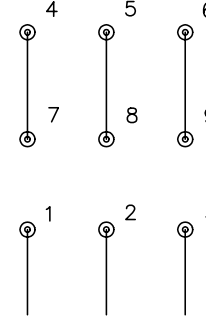

LINE

NOTES:

1. INTERCHANGE ANY TWO LINE LEADS TO REVERSE ROTATION.
2. OPTIONAL THERMOSTATS ARE PROVIDED WHEN SPECIFIED.
3. ACTUAL NUMBER OF INTERNAL PARALLEL CIRCUITS MAY BE A MULTIPLE OF THOSE SHOWN ABOVE.
4. LEAD COLORS ARE OPTIONAL. LEADS MUST ALWAYS BE NUMBERED AS SHOWN.

REV. DESC: REVISE TO SHOW OPTIONAL COLORS			
REV. LTR: E	BY: JLP	REVISED: 01/19/99 10:15	TDR: 0171435
900000		FILE: AAA00005140	MDL: -
		MTL: -	

BALDOR ELECTRIC Co.

3PH, DV, 9 LEADS

CD0005

Marketing maintained PDF of MN416:

<http://www.baldor.com/support/Literature/Load.ashx/MN416?ManNumber=MN416>