

BALDOR® • RELIANCE 

Product Information Packet

XT3072T-180

7.5HP,3450RPM,3PH,60HZ,184T,0642M,TEFC,F

Part Detail							
Revision:	A	Status:	PRD/A	Change #:		Proprietary:	No
Type:	AC	Elec. Spec:	06WGY359	CD Diagram:	CD0005	Mfg Plant:	
Mech. Spec:		Layout:	06LYF436	Poles:	02	Created Date:	12-02-2020
Base:		Eff. Date:	04-07-2021	Leads:	9#16		

Specs			
Catalog Number:	XT3072T-180	Electrically Isolated Bearing:	Not Electrically Isolated
Enclosure:	TEFC	Feedback Device:	NO FEEDBACK
Frame:	184T	Heater Indicator:	No Heater
Frame Material:	Iron	Insulation Class:	F
Output @ Frequency:	7.500 HP @ 60 HZ	Inverter Code:	Inverter Duty
Synchronous Speed @ Frequency:	3600 RPM @ 60 HZ	IP Rating:	NONE
Voltage @ Frequency:	460.0 V @ 60 HZ	KVA Code:	M
	230.0 V @ 60 HZ	Lifting Lugs:	Standard Lifting Lugs
	208.0 V @ 60 HZ	Locked Bearing Indicator:	No Locked Bearing
XP Class and Group:	CLI GP A,B,C,D	Motor Lead Termination:	Flying Leads
XP Division:	Division II	Motor Type:	0642M
Agency Approvals:	CCSA US	Mounting Arrangement:	F1
	CSA EEV	Power Factor:	92
	NEMA PREMIUM	Product Family:	General Purpose
	UR	Pulley Face Code:	Standard
Auxillary Box:	No Auxillary Box	Rodent Screen:	None
Auxillary Box Lead Termination:	None	Shaft Ground Indicator:	No Shaft Grounding
Base Indicator:	Rigid	Shaft Rotation:	Reversible

Bearing Grease Type:	Polyrex EM (-20F +300F)	Speed Code:	Single Speed
Blower:	None	Motor Standards:	NEMA
Constant Torque Speed Range:	6	Starting Method:	Direct on line
Current @ Voltage:	8.400 A @ 460.0 V	Thermal Device - Bearing:	None
	18.600 A @ 208.0 V	Thermal Device - Winding:	None
	16.800 A @ 230.0 V	Vibration Sensor Indicator:	No Vibration Sensor
Design Code:	A	Winding Thermal 1:	None
Drip Cover:	No Drip Cover	Winding Thermal 2:	None
Duty Rating:	CONT	XP Temp Code:	T3C

Nameplate NP4225L			
CAT.NO.	XT3072T-180	I.P.	54
SPEC.	06-0000-0804	ENCL	TEFC
FRAME	184T	H.P.	7.5
VOLTS	208-230/460	P.F.	92
F.L. AMPS	18.6-16.8/8.4	RATING	40C AMB-CONT
R.P.M.	3450	USABLE AT 208V	
HZ.	60	PH.	3
SER.F.	1.15	DES.	A
NEMA NOM. EFF.	89.5	W _{K2}	0.19
DE	6206	ODE	6205
MAG. CUR.	8/4	CHP	60
INV TYPE	PWM	TO	90
CT	6	VT	6
	TO 60	TO	60
CC	010A	SN	
	50 HZ 5HP 190/380V		
	14/7 A		

Parts List		
Part Number	Description	Quantity
SA388543	SA 06-0000-0804	1.000 EA
RA378908	RA 06-0000-0804	1.000 EA
LB1115N	LABEL,LIFTING DEVICE (ON ROLLS)	1.000 EA
LC0005E01	CONN.DIA./WARNING LABEL (LC0005/LB1119N)	1.000 EA
NP4225L	SS SEVERE DUTY XT INV UL CSA	1.000 EA
85XU0407S04	4X1/4 U DRIVE PIN STAINLESS	2.000 EA
MN416A01	TAG-INSTAL-MAINT no wire (2100/bx) 4/22	1.000 EA
HW3201A05	3/8-16 EYEBOLT	1.000 EA
36FH4009A101	IEC FH NO GREASER, W/PRIMER	1.000 EA
51XW1032A06	10-32 X .38, TAPTITE II, HEX WSHR SLTD S	3.000 EA
34FN3002A02	EXTERNAL FAN, PLASTIC, .905/.907 HUB W/	1.000 EA
51XB0818A12	8-18X3/4 HXWSSLD SERTYB	1.000 EA
MJ1000A02	GREASE, MOBIL POLYREX EM - 124047	0.050 LB
HA3101A34	THRUBOLT- 1/4-20 X 10.375	4.000 EA
XY2520A12	1/4-20 HEX NUT, DIRECTIONAL SERRATIONS	4.000 EA
36EP3104B47	FREP MACH W/O GRSS,RAISED FH PADS,SLING	1.000 EA
HW4600B32SP	V-RING SLINGER 1.000 X 1.540 X .24 VITON	1.000 EA
HW5100A05	WVY WSHR F/205 & 304 BRGS	1.000 EA
HA4067A01	PUSH IN DRAIN FITTING (BLACK)	1.000 EA
36EP3100A04	PU ENDPLATE, MACH	1.000 EA
HW4600B36SP	V-RING SLINGER 1.188 X 1.690 X .24 VITON	1.000 EA
HA4067A01	PUSH IN DRAIN FITTING (BLACK)	1.000 EA
06CB3000	BALDOR CONDUIT BOX CAST	1.000 EA
06GS1000	GASKET,CONDUIT BOX	1.000 EA

Parts List (continued)		
Part Number	Description	Quantity
51XW2520A12	SCREW, HEX SER SLT HD, ZN, 1/4-20 X .75	2.000 EA
11XW1032G06	10-32 X .38, TAPTITE II, HEX WSHR SLTD U	1.000 EA
HW3001B02	BRASS CUP WASHER W/GROUND SYMBOL TAB,	1.000 EA
06CB3500	BALDOR CONDUIT BOX LID	1.000 EA
06GS1001	BALDOR CONDUIT BOX GASKET	1.000 EA
51XW2520A12	.25-20 X .75, TAPTITE II, HEX WSHR SLTD	2.000 EA
MG1025L14	WILKOFASST, 776.14, GRUNDFOS BLACK	0.125 GA
36PA1001	PKG GRP, PRINT PK1017A06	1.000 EA
HW2501E16	KEY, 1/4 SQ X 1.750	1.000 EA
HA7000A02	KEY RETAINER RING, 1 1/8 DIA, 1 3/8 DIA	1.000 EA

AC Induction Motor Performance Data

Record # 63183

Typical performance - not guaranteed values

Winding: 06WGY359-REV-		Type: 0643M		Enclosure: TEFC	
Nameplate Data			460 V, 60 Hz: High Voltage Connection		
Rated Output (HP)	7.5	Full Load Torque	11.4 LB-FT		
Volts	208-230/460	Start Configuration	direct on line		
Full Load Amps	18.4-16.8/8.4	Breakdown Torque	59.4 LB-FT		
R.P.M.	3450	Pull-up Torque	35.4 LB-FT		
Hz	60 Phase	3	Locked-rotor Torque	46.5 LB-FT	
NEMA Design Code	A KVA Code	L	Starting Current	97.1 A	
Service Factor (S.F.)		1	No-load Current	2.36 A	
NEMA Nom. Eff.	90.2 Power Factor	91	Line-line Res. @ 25°C	1.4056 Ω	
Rating - Duty	40C AMB-CONT		Temp. Rise @ Rated Load	68°C	

Load Characteristics 460 V, 60 Hz, 7.5 HP

% of Rated Load	25	50	75	100	125	150
Power Factor	66	84	90	92	94	94
Efficiency	87.5	90.9	90.9	90	88.7	86.9
Speed	3571.8	3542.1	3508.5	3473.7	3437.3	3393.8
Line amperes	3.12	4.63	6.51	8.5	10.5	12.9

Performance Graph at 460V, 60Hz, 7.5HP Typical performance - Not guaranteed values

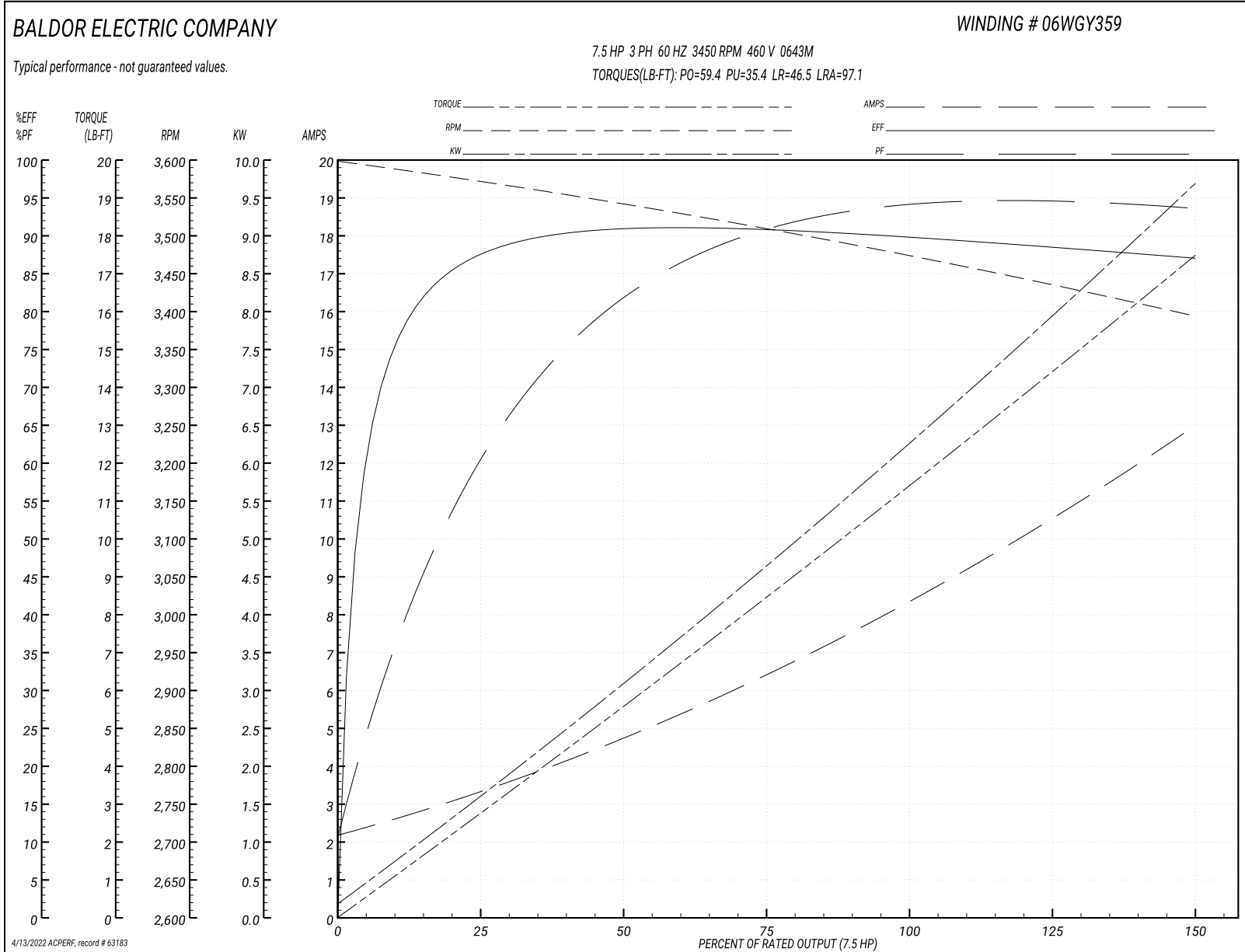

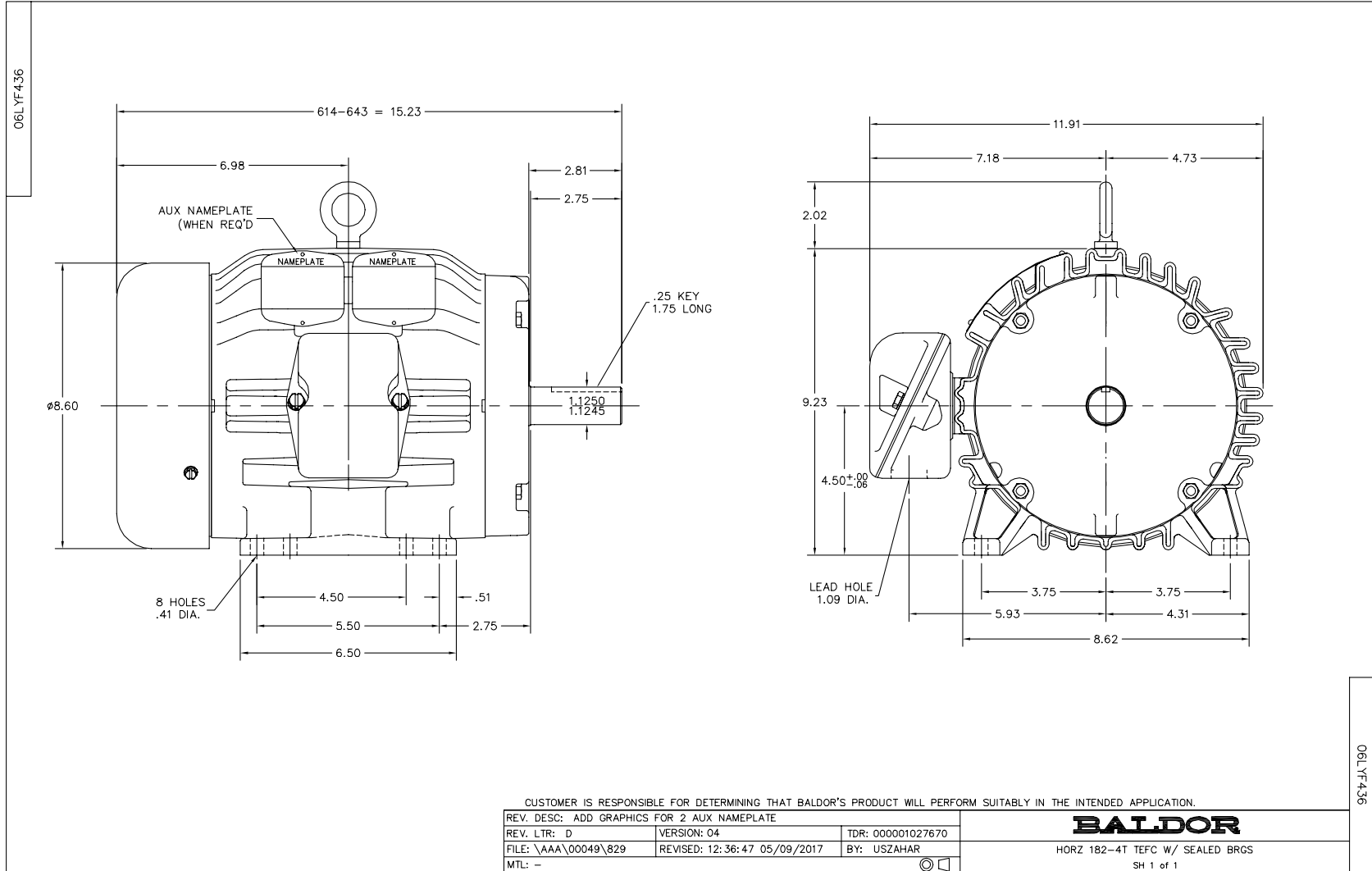

CD0005



LOW VOLTAGE
(2Y)



LINE

HIGH VOLTAGE
(1Y)



LINE

NOTES:

1. INTERCHANGE ANY TWO LINE LEADS TO REVERSE ROTATION.
2. OPTIONAL THERMOSTATS ARE PROVIDED WHEN SPECIFIED.
3. ACTUAL NUMBER OF INTERNAL PARALLEL CIRCUITS MAY BE A MULTIPLE OF THOSE SHOWN ABOVE.
4. LEAD COLORS ARE OPTIONAL. LEADS MUST ALWAYS BE NUMBERED AS SHOWN.

REV. DESC: REVISE TO SHOW OPTIONAL COLORS

REV. LTR: E BY: JLP

REVISED: 01/19/99 10:15

TDR: 0171435

900003

FILE: AAA00005140

MDL: -

MTL: -

BALDOR ELECTRIC Co.

3PH, DV, 9 LEADS

CD0005

Marketing maintained PDF of MN416:

<http://www.baldor.com/support/Literature/Load.ashx/MN416?ManNumber=MN416>