

BALDOR® • RELIANCE 

Product Information Packet

XT3202T-5

20HP,3520RPM,3PH,60HZ,256T,0936M,TEFC,F1

Part Detail							
Revision:	A	Status:	PRD/A	Change #:		Proprietary:	No
Type:	AC	Elec. Spec:	09WGZ699	CD Diagram:	CD0006	Mfg Plant:	
Mech. Spec:		Layout:	09LY-001-224	Poles:	02	Created Date:	07-20-2021
Base:		Eff. Date:	08-25-2021	Leads:	3#12		

Specs			
Catalog Number:	XT3202T-5	Heater Indicator:	No Heater
Enclosure:	TEFC	Insulation Class:	F
Frame:	256T	Inverter Code:	Inverter Duty
Frame Material:	Iron	IP Rating:	NONE
Output @ Frequency:	20.000 HP @ 60 HZ	KVA Code:	H
Synchronous Speed @ Frequency:	3600 RPM @ 60 HZ	Lifting Lugs:	Standard Lifting Lugs
Voltage @ Frequency:	575.0 V @ 60 HZ	Locked Bearing Indicator:	Locked Bearing
XP Class and Group:	CLI GP A,B,C,D	Motor Lead Termination:	Flying Leads
XP Division:	Division II	Motor Type:	0936M
Agency Approvals:	CCSA US	Mounting Arrangement:	F1
	CSA EEV	Power Factor:	88
	NEMA PREMIUM	Product Family:	General Purpose
	UR	Pulley Face Code:	Standard
Auxillary Box:	No Auxillary Box	Rodent Screen:	None
Auxillary Box Lead Termination:	None	Shaft Ground Indicator:	No Shaft Grounding
Base Indicator:	Rigid	Shaft Rotation:	Reversible
Bearing Grease Type:	Polyrex EM (-20F +300F)	Speed Code:	Single Speed
Blower:	None	Motor Standards:	NEMA

Constant Torque Speed Range:	6	Starting Method:	Direct on line
Current @ Voltage:	18.000 A @ 575.0 V	Thermal Device - Bearing:	None
Design Code:	A	Thermal Device - Winding:	None
Drip Cover:	No Drip Cover	Vibration Sensor Indicator:	No Vibration Sensor
Duty Rating:	CONT	Winding Thermal 1:	None
Electrically Isolated Bearing:	Not Electrically Isolated	Winding Thermal 2:	None
Feedback Device:	NO FEEDBACK	XP Temp Code:	T3

Nameplate NP4224L					
CAT.NO.	XT3202T-5		I.P.	54	
SPEC.	09-0000-3295		ENCL	TEFC	
FRAME	256T	H.P.	20	T. CODE	T3
VOLTS	575	P.F.	88		
F.L. AMPS	18	RATING	40C AMB-CONT		
R.P.M.	3520	USABLE AT 208V			
HZ.	60	PH.	3	CLASS	F
SER.F.	1.15	DES.	A	SL HZ	1.3
NEMA NOM. EFF.	91	WV	0.92		
DE	6309	ODE	6208		
MAG. CUR.	5.7				
INV TYPE	PWM	CHP	60	TO	90
CT	6	TO	60	VT	6
CC	010A	SN			
				INV TEMP CODE	T3

Parts List		
Part Number	Description	Quantity
SA395657	SA 09-0000-3295	1.000 EA
RA386412	RA 09-0000-3295	1.000 EA
LB1115N	LABEL,LIFTING DEVICE (ON ROLLS)	1.000 EA
LB1119N	WARNING LABEL	1.000 EA
LC0006	CONNECTION LABEL	1.000 EA
LB1449	DIV-2/NEC WARNING LABEL	1.000 EA
NP4224L	SS CP INV DIV-2 UL CSA-C US EEV PREM, DI	1.000 EA
85XU0407S04	4X1/4 U DRIVE PIN STAINLESS	2.000 EA
MN416A01	TAG-INSTAL-MAINT no wire (2100/bx) 4/22	1.000 EA
HW3201A01	1/2-13 EYEBOLT	1.000 EA
HW1002A63	WASHER, 5/8 HI-COLLAR SPRLCKWASHER	1.000 EA
09FH4000SP	309 FH - BLACK PRIMER	1.000 EA
HW1001A38	LOCKWASHER 3/8, ZINC PLT .688 OD, .382 I	4.000 EA
XY3816A12	3/8-16 FINISHED NUT	4.000 EA
37FN3002C02	EXFN, PLASTIC, 6.00 OD, 1.503 ID	1.000 EA
HW2500A25	WOODRUFF KEY USA #1008 #BLOW CARBON STEE	1.000 EA
MJ1000A02	GREASE, MOBIL POLYREX EM - 124047	0.080 LB
09EP1100A196	ENDPLATE, MACH	1.000 EA
HA3400A33	STUD- 3/8-16 X 4.82 HEX WELKER	4.000 EA
HW1001A38	LOCKWASHER 3/8, ZINC PLT .688 OD, .382 I	4.000 EA
HW5100A08	W3118-035 WVY WSHR (WB)	1.000 EA
HA4066A01	PUSH IN T-DRAIN FITTING (BLACK)	1.000 EA
09EP1101A168	PU ENDPLATE, MACH W/NO GREASER HOLES	1.000 EA
HW1001A38	LOCKWASHER 3/8, ZINC PLT .688 OD, .382 I	4.000 EA

Parts List (continued)		
Part Number	Description	Quantity
10XN3816K28	3/8-16 X 1.75 HEX HD CAP SCREW, GRADE 5	4.000 EA
HW4600B44	V-RING SLINGER 1.500 X 1.810 X .28 VITON	1.000 EA
HW4600B44	V-RING SLINGER 1.500 X 1.810 X .28 VITON	1.000 EA
10XN2520K36	1/4-20 X 2.25" HX HD SCRWGRADE 5, ZINC P	4.000 EA
HW1001A25	LOCKWASHER 1/4, ZINC PLT .493 OD, .255 I	4.000 EA
HA4066A01	PUSH IN T-DRAIN FITTING (BLACK)	1.000 EA
09CB3003	CB W/1.75" DIA LD HL - 37, 39, 307 & 309	1.000 EA
09GS1000SP	GASKET-CONDUIT BOX, 1/16 THICK LEXIDE	1.000 EA
51XW2520A12	.25-20 X .75, TAPTITE II, HEX WSHR SLTD	4.000 EA
WD1000B16	T&B CX70TN OR L70P TERMINAL LUG	1.000 EA
59XW2520G07	.25-20X.44,HEX SER WSHR,TAPTITE 2,GREEN	1.000 EA
09CB3501SP	CONDUIT BOX LID FOR 09CB3001 & 09CB3002	1.000 EA
09GS1013SP	GS FOR 09CB3501, 12CB1500 & 12CB1503 LID	1.000 EA
51XW2520A12	.25-20 X .75, TAPTITE II, HEX WSHR SLTD	2.000 EA
MG1025L14	WILKOFASST, 776.14, GRUNDFOS BLACK	0.070 GA
09PA1000	PACKAGING GROUP COMBINED PRINT	1.000 EA
HW2501G25	KEY, 3/8 SQ X 2.875	1.000 EA

AC Induction Motor Performance Data

Record # 33069

Typical performance - not guaranteed values

Winding: 09WGZ699-R001		Type: 0936M	Enclosure: TEFC
Nameplate Data		575 V, 60 Hz: Single Voltage Motor	
Rated Output (HP)	20	Full Load Torque	29.7 LB-FT
Volts	575	Start Configuration	direct on line
Full Load Amps	18	Breakdown Torque	110 LB-FT
R.P.M.	3520	Pull-up Torque	39 LB-FT
Hz	60 Phase	Locked-rotor Torque	49.5 LB-FT
NEMA Design Code	A KVA Code	Starting Current	129 A
Service Factor (S.F.)	1.15	No-load Current	5.75 A
NEMA Nom. Eff.	91 Power Factor	Line-line Res. @ 25°C	0.732 Ω
Rating - Duty	40C AMB-CONT	Temp. Rise @ Rated Load	78°C
S.F. Amps		Temp. Rise @ S.F. Load	98°C
		Locked-rotor Power Factor	29.5
		Rotor inertia	0.92 lb-ft ²

Load Characteristics 575 V, 60 Hz, 20 HP

% of Rated Load	25	50	75	100	125	150	S.F.
Power Factor	58	78	86	88	90	90	89
Efficiency	88.4	91.9	92.2	91.7	90.3	89	90.9
Speed	3580	3562	3541	3519	3495	3468	3505
Line amperes	7.21	10.4	14.2	18.4	22.9	28	21.1

Performance Graph at 575V, 60Hz, 20.0HP Typical performance - Not guaranteed values

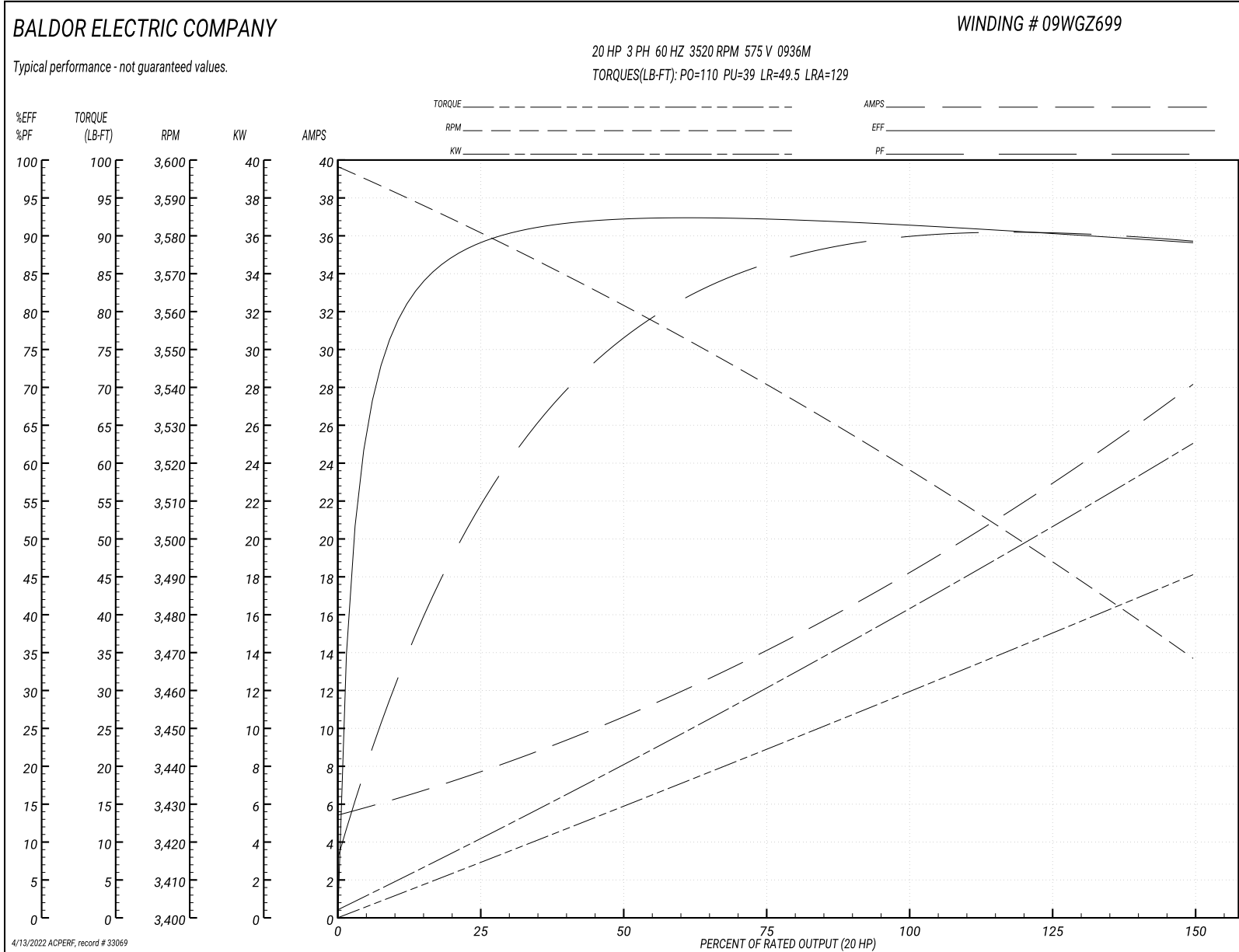

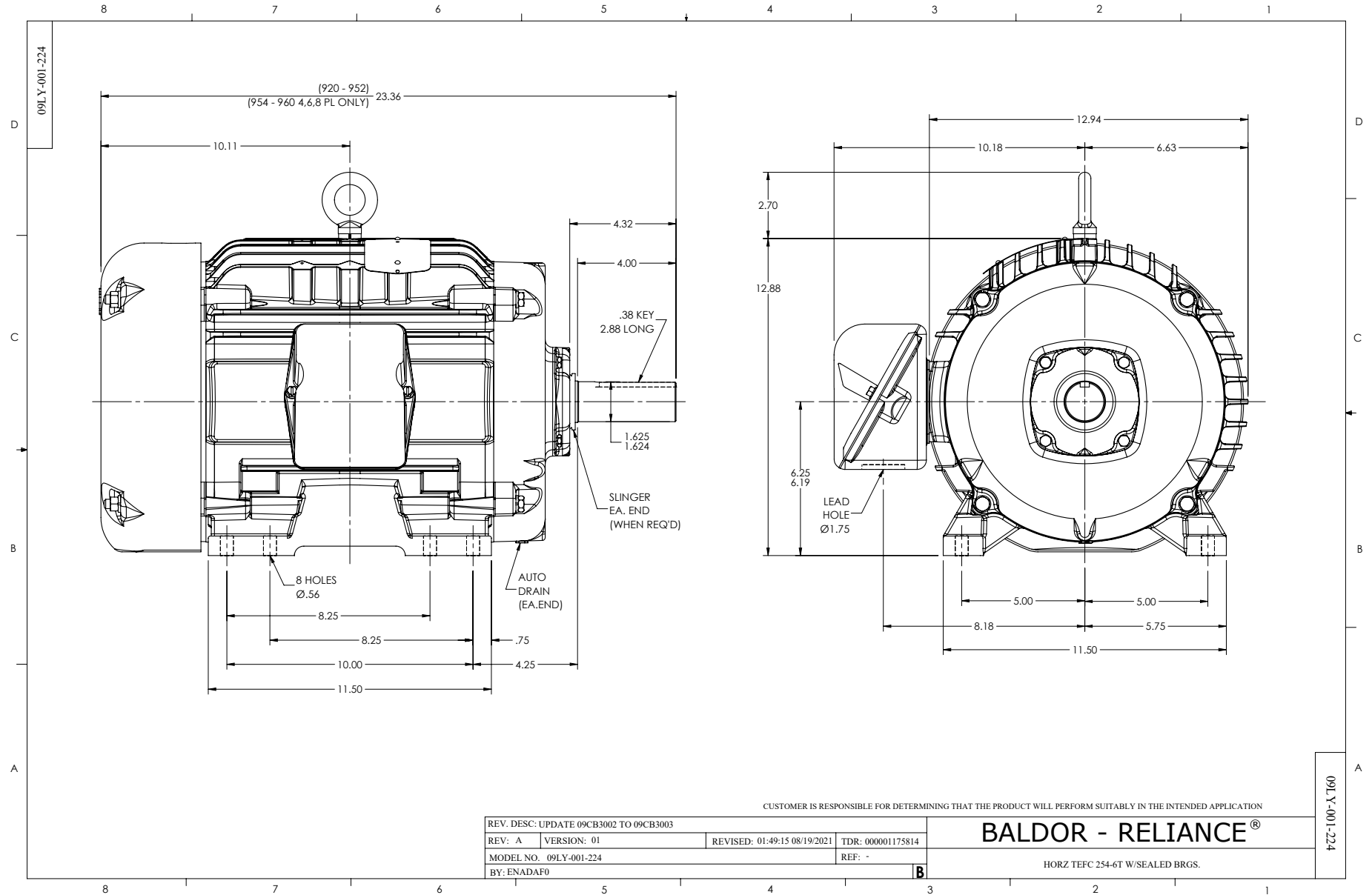

CD0006



NOTES:

1. THREE LEAD MOTOR MAY BE EITHER WYE CONNECTED OR DELTA CONNECTED.
2. INTERCHANGE ANY TWO LINE LEADS TO REVERSE ROTATION.
3. OPTIONAL THERMOSTATS ARE PROVIDED WHEN SPECIFIED.
4. ACTUAL NUMBER OF INTERNAL PARALLEL CIRCUITS MAY VARY.
5. LEAD COLORS ARE OPTIONAL. LEADS MUST BE NUMBERED AS SHOWN.

CD0006

REV. DESC: ADD CLASS CONN00000007		
REV. LTR: E	VERSION: 01	TDR: 000001099922
FILE: \AAA\00005\141	REVISED: 10:24:49 02/19/2019	BY: ENBRIRO
MTL: -	© □	

BALDOR - RELIANCE®

3PH, SV, 3 LEADS, WYE OR DELTA CONNECTED

SH 1 of 1

Marketing maintained PDF of MN416:

<http://www.baldor.com/support/Literature/Load.ashx/MN416?ManNumber=MN416>