

BALDOR® • RELIANCE 

Product Information Packet

XT3254T

25HP,1770RPM,3PH,60HZ,284T,1056M,TEFC,F1

Part Detail							
Revision:	B	Status:	PRD/A	Change #:		Proprietary:	No
Type:	AC	Elec. Spec:	10WUZ624	CD Diagram:	CD0005	Mfg Plant:	
Mech. Spec:		Layout:	10LYC151	Poles:	04	Created Date:	11-18-2020
Base:		Eff. Date:	06-15-2021	Leads:	9#10		

Specs			
Catalog Number:	XT3254T	Electrically Isolated Bearing:	Not Electrically Isolated
Enclosure:	TEFC	Feedback Device:	NO FEEDBACK
Frame:	284T	Heater Indicator:	No Heater
Frame Material:	Iron	Insulation Class:	F
Output @ Frequency:	25.000 HP @ 60 HZ	Inverter Code:	Inverter Duty
Synchronous Speed @ Frequency:	1800 RPM @ 60 HZ	IP Rating:	NONE
Voltage @ Frequency:	230.0 V @ 60 HZ	KVA Code:	F
	460.0 V @ 60 HZ	Lifting Lugs:	Standard Lifting Lugs
XP Class and Group:	CLI GP A,B,C,D	Locked Bearing Indicator:	Locked Bearing
XP Division:	Division II	Motor Lead Termination:	Flying Leads
Agency Approvals:	CCSA US	Motor Type:	1056M
	CSA EEV	Mounting Arrangement:	F1
	NEMA PREMIUM	Power Factor:	85
	UR	Product Family:	General Purpose
Auxillary Box:	No Auxillary Box	Pulley Face Code:	Standard
Auxillary Box Lead Termination:	None	Rodent Screen:	None
Base Indicator:	Rigid	Shaft Ground Indicator:	No Shaft Grounding
Bearing Grease Type:	Polyrex EM (-20F +300F)	Shaft Rotation:	Reversible

Blower:	None	Speed Code:	Single Speed
Constant Torque Speed Range:	3	Motor Standards:	NEMA
Current @ Voltage:	60.000 A @ 230.0 V	Starting Method:	Direct on line
	64.000 A @ 208.0 V	Thermal Device - Bearing:	None
	30.000 A @ 460.0 V	Thermal Device - Winding:	None
Design Code:	B	Vibration Sensor Indicator:	No Vibration Sensor
Drip Cover:	No Drip Cover	Winding Thermal 1:	None
Duty Rating:	CONT	Winding Thermal 2:	None
		XP Temp Code:	T3C

Nameplate NP4163L				
CAT.NO.	XT3254T		I.P.	54
SPEC.	10-0000-1828		ENCL	TEFC
FRAME	284T	H.P.	25	
VOLTS	230/460	P.F.	85	
F.L. AMPS	60/30		RATING	40C AMB-CONT
R.P.M.	1770	PH.	3	USABLE AT 208V 64
HZ.	60	DES.	B	CLASS F
SER.F.	1.15	ODE	6309	
NEMA NOM. EFF.	93.6	WV	4.46	SL HZ 1
DE	6311	TO	90	T. CODE T3A
MAG. CUR.	20.8/10.4		VT	3
INV TYPE	PWM	CHP	60	TO 60
CT	3	SN		
CC	010A			
USABLE AT 50 HZ 20HP 190/380V				
58/29A				

Parts List		
Part Number	Description	Quantity
SA388658	SA 10-0000-1828	1.000 EA
RA379023	RA 10-0000-1828	1.000 EA
LB1115N	LABEL,LIFTING DEVICE (ON ROLLS)	1.000 EA
LC0005E01	SPL CONN.DIA./WARN.LABEL(LC0005/LB1119)	1.000 EA
LB1449	DIV-2/NEC WARNING LABEL	1.000 EA
NP4163L	SS CP INV DIV-2 UL CSA-C US EEV PREM, DI	1.000 EA
85XU0407S04	4X1/4 U DRIVE PIN STAINLESS	2.000 EA
MN416A01	TAG-INSTAL-MAINT no wire (2100/bx) 4/22	1.000 EA
10FH4000	310 FAN HOUSING STAMPED	1.000 EA
51XF2520A08	SCREW, HEX SER SLT HD, ZN 1/4-20 X .50 L	4.000 EA
09FN3001D02	EXTERNAL FAN, PLASTIC (COMES W/SCREW FRO	1.000 EA
HW2500A25	WOODRUFF KEY USA #1008 #BLOW CARBON STEE	1.000 EA
MJ1000A02	GREASE, MOBIL POLYREX EM - 124047	0.130 LB
10EP1106A81	FREP TEFC W/"O" DRAIN W/O RET RING HLS	1.000 EA
10XN3816K32	BOLT, 3/8-16X2 HH YZ(5)	4.000 EA
HW1001A38	LOCKWASHER 3/8, ZINC PLT .688 OD, .382 I	4.000 EA
HW4600B67	V-RING SLINGER 1.770 X 2.170 X .28 VITON	1.000 EA
HW5100A11	W3917-042 WVY WSHR (WB)	1.000 EA
HA4017A11	1/8 X 2.75 GREASE EXT (F/S)	1.000 EA
HA4051A00	PLASTIC CAP FOR GREASE FITTING	1.000 EA
HW4500A21	1618BALEMITE FITTING 825 UNIVERSAL	1.000 EA
HW4500A17	317400 ALEMITE GREASE RELIEF	1.000 EA
HA4066A01	PUSH IN T-DRAIN FITTING (BLACK)	1.000 EA
10EP1105A113	PU ENDPLATE, MACH	1.000 EA

Parts List (continued)		
Part Number	Description	Quantity
HW1001A38	LOCKWASHER 3/8, ZINC PLT .688 OD, .382 I	4.000 EA
10XN3816K28	3/8-16 X 1.75 HEX HD CAP SCREW, GRADE 5	4.000 EA
HW4600B40	V-RING SLINGER 2.000 X 2.680 X .28 VITON	1.000 EA
10XN3118K40	5/16-18 X 2.50" HEX HD, GRADE 5	4.000 EA
HW1001A31	LOCKWASHER 5/16, ZINC PLT.591 OD, .319 I	4.000 EA
HA4051A00	PLASTIC CAP FOR GREASE FITTING	1.000 EA
HW4500A03	GREASE FITTING, .125 NPT 1610(ALEMITE) 8	1.000 EA
HW4500A17	317400 ALEMITE GREASE RELIEF	1.000 EA
HA4066A01	PUSH IN T-DRAIN FITTING (BLACK)	1.000 EA
10CB3000	CONDUIT BOX, MACH W/2.00 LEAD HOLE	1.000 EA
09GS1000SP	GASKET-CONDUIT BOX, 1/16 THICK LEXIDE	1.000 EA
10XN3118K12	5/16-18 X .75 GRADE 5, ZINC PLATED	4.000 EA
HW1001A31	LOCKWASHER 5/16, ZINC PLT.591 OD, .319 I	4.000 EA
WD1000B25	GND LUG, BURNDY L125HP OR T&B L125HP-BB	1.000 EA
19XW3118G08	.31-18X.50,HEX WSHR HD,TAPTITE 2,GREEN	1.000 EA
10CB3500SP	CONDUIT BOX LID, CAST	1.000 EA
10GS1000SP	GASKET, CONDUIT BOX LID	1.000 EA
51XW2520A12	.25-20 X .75, TAPTITE II, HEX WSHR SLTD	4.000 EA
MG1025L14	WILKOFAS, 776.14, GRUNDFOS BLACK	0.125 GA
10PA1000	PACKAGING GROUP COMBINED PRINT PK1023A06	1.000 EA
HW2501H28	KEY, 1/2 SQ X 3.250	1.000 EA

AC Induction Motor Performance Data

Record # 62432

Typical performance - not guaranteed values

Winding: 10WGZ624-R001		Type: 1056M	Enclosure: TEFC
Nameplate Data		460 V, 60 Hz: High Voltage Connection	
Rated Output (HP)	25	Full Load Torque	74.31 LB-FT
Volts	460	Start Configuration	direct on line
Full Load Amps	30	Breakdown Torque	197 LB-FT
R.P.M.	1770	Pull-up Torque	91.4 LB-FT
Hz	60 Phase	Locked-rotor Torque	115 LB-FT
NEMA Design Code	B KVA Code	Starting Current	173 A
Service Factor (S.F.)	1.15	No-load Current	10.4 A
NEMA Nom. Eff.	93.6 Power Factor	Line-line Res. @ 25°C	0.29877 Ω
Rating - Duty	40C AMB-CONT	Temp. Rise @ Rated Load	54°C
S.F. Amps		Temp. Rise @ S.F. Load	67°C
		Locked-rotor Power Factor	30.3

Load Characteristics 460 V, 60 Hz, 25 HP

% of Rated Load	25	50	75	100	125	150	S.F.
Power Factor	51	73	81	85	86	86	86
Efficiency	91	93.8	94.1	93.7	92.9	91.8	93.2
Speed	1792.8	1785.5	1778.9	1770.7	1762.4	1751.5	1766
Line amperes	12.5	17	22.9	29.5	36.5	44.7	33.7

Performance Graph at 460V, 60Hz, 25.0HP Typical performance - Not guaranteed values

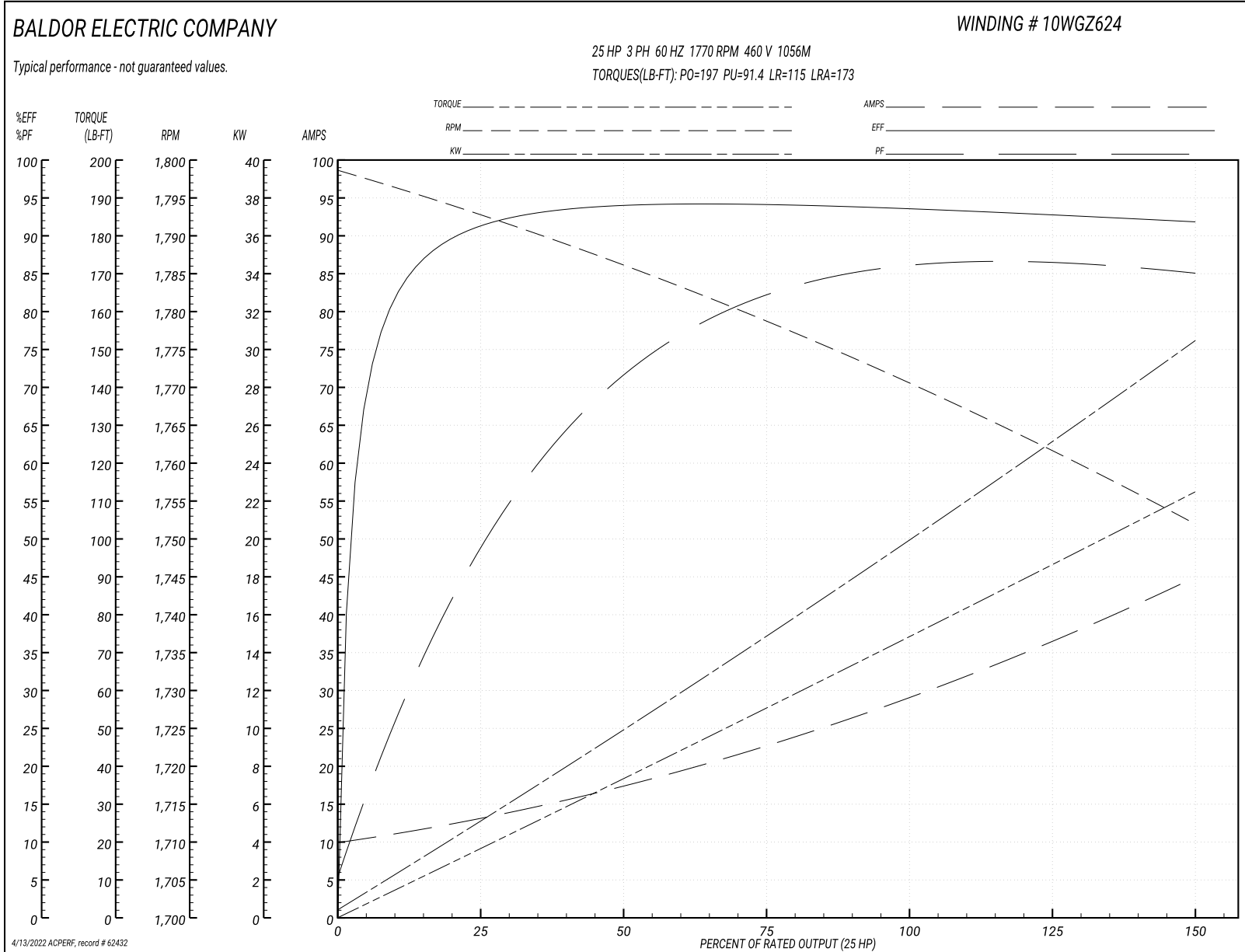

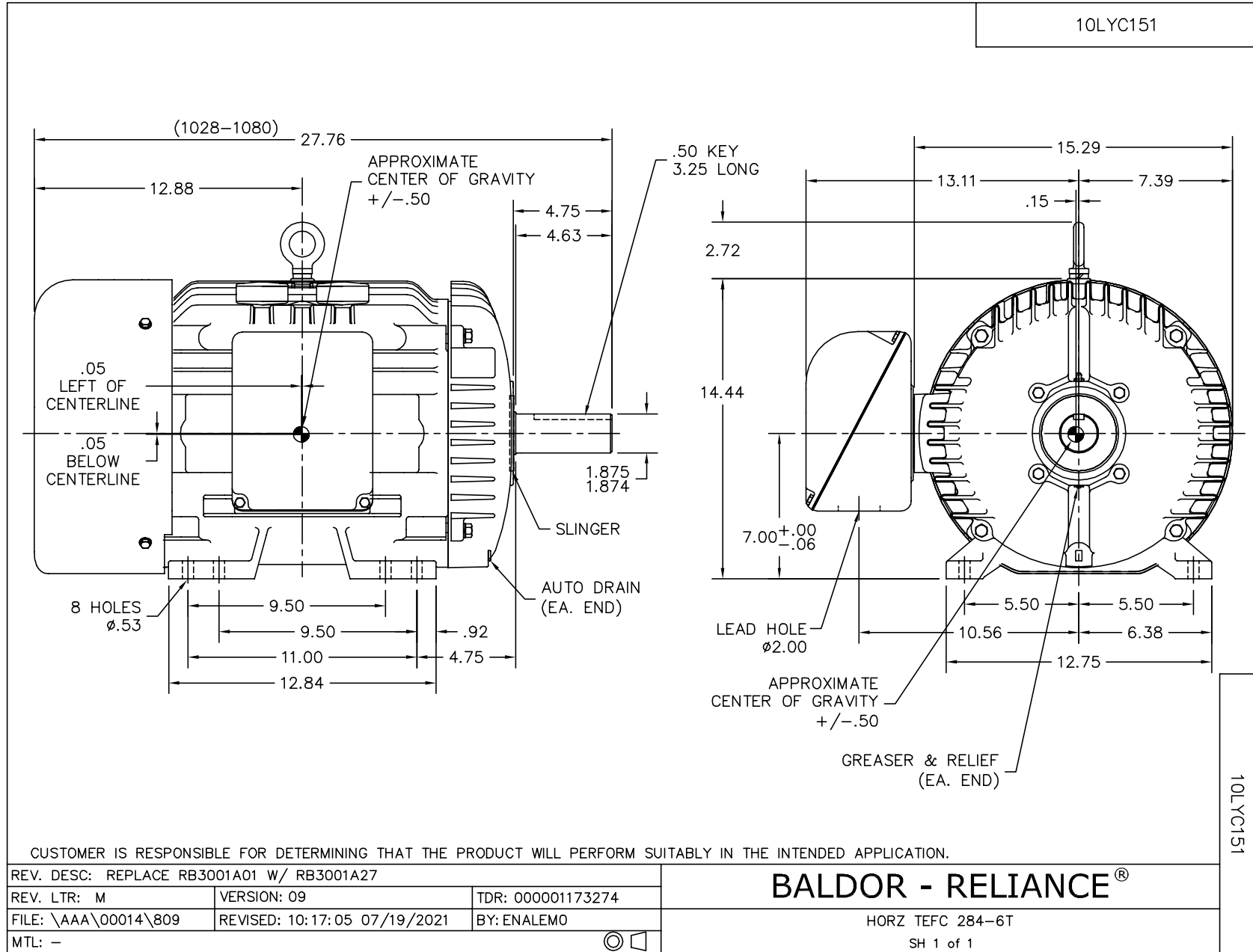

CD0005



LOW VOLTAGE
(2Y)



LINE

HIGH VOLTAGE
(1Y)

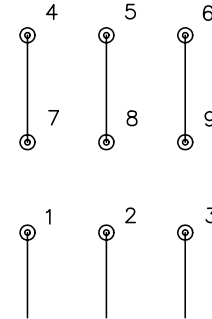

LINE

NOTES:

1. INTERCHANGE ANY TWO LINE LEADS TO REVERSE ROTATION.
2. OPTIONAL THERMOSTATS ARE PROVIDED WHEN SPECIFIED.
3. ACTUAL NUMBER OF INTERNAL PARALLEL CIRCUITS MAY BE A MULTIPLE OF THOSE SHOWN ABOVE.
4. LEAD COLORS ARE OPTIONAL. LEADS MUST ALWAYS BE NUMBERED AS SHOWN.

REV. DESC: REVISE TO SHOW OPTIONAL COLORS			
REV. LTR: E	BY: JLP	REVISED: 01/19/99 10:15	TDR: 0171435
90000		FILE: AAA00005140	MDL: -
		MTL: -	

BALDOR ELECTRIC Co.

3PH, DV, 9 LEADS

CD0005

Marketing maintained PDF of MN416:

<http://www.baldor.com/support/Literature/Load.ashx/MN416?ManNumber=MN416>