

BALDOR® • RELIANCE 

Product Information Packet

XT3306T-5

30HP,1180RPM,3PH,60HZ,326T,1264M,TEFC,F1

Part Detail							
Revision:	-	Status:	PRD/A	Change #:		Proprietary:	No
Type:	AC	Elec. Spec:	12WGY454	CD Diagram:	CD0006	Mfg Plant:	
Mech. Spec:		Layout:	12LYH013	Poles:	06	Created Date:	07-21-2021
Base:		Eff. Date:	07-28-2021	Leads:	3#8		

Specs			
Catalog Number:	XT3306T-5	Heater Indicator:	No Heater
Enclosure:	TEFC	Insulation Class:	F
Frame:	326T	Inverter Code:	Inverter Duty
Frame Material:	Iron	IP Rating:	NONE
Output @ Frequency:	30.000 HP @ 60 HZ	KVA Code:	G
Synchronous Speed @ Frequency:	1200 RPM @ 60 HZ	Lifting Lugs:	Standard Lifting Lugs
Voltage @ Frequency:	575.0 V @ 60 HZ	Locked Bearing Indicator:	Locked Bearing
XP Class and Group:	CLI GP A,B,C,D	Motor Lead Termination:	Flying Leads
XP Division:	Division II	Motor Type:	1264M
Agency Approvals:	CCSA US	Mounting Arrangement:	F1
	CSA EEV	Power Factor:	78
	NEMA PREMIUM	Product Family:	General Purpose
	UR	Pulley Face Code:	Standard
Auxillary Box:	No Auxillary Box	Rodent Screen:	None
Auxillary Box Lead Termination:	None	Shaft Ground Indicator:	No Shaft Grounding
Base Indicator:	Rigid	Shaft Rotation:	Reversible
Bearing Grease Type:	Polyrex EM (-20F +300F)	Speed Code:	Single Speed
Blower:	None	Motor Standards:	NEMA

Constant Torque Speed Range:	3	Starting Method:	Direct on line
Current @ Voltage:	30.900 A @ 575.0 V	Thermal Device - Bearing:	None
Design Code:	A	Thermal Device - Winding:	None
Drip Cover:	No Drip Cover	Vibration Sensor Indicator:	No Vibration Sensor
Duty Rating:	CONT	Winding Thermal 1:	None
Electrically Isolated Bearing:	Not Electrically Isolated	Winding Thermal 2:	None
Feedback Device:	NO FEEDBACK	XP Temp Code:	T3

Parts List		
Part Number	Description	Quantity
SA395687	SA 12-0000-2272	1.000 EA
RA386442	RA 12-0000-2272	1.000 EA
LB1115N	LABEL,LIFTING DEVICE (ON ROLLS)	1.000 EA
LB1119N	WARNING LABEL	1.000 EA
LC0006	CONNECTION LABEL	1.000 EA
LB1449	DIV-2/NEC WARNING LABEL	1.000 EA
NP4224L	SS CP INV DIV-2 UL CSA-C US EEV PREM, DI	1.000 EA
85XU0407S04	4X1/4 U DRIVE PIN STAINLESS	2.000 EA
MN416A01	TAG-INSTAL-MAINT no wire (2100/bx) 4/22	1.000 EA
12FH1002SP	FAN COVER, CAST	1.000 EA
HW1001A50	LOCKWASHER 1/2, ZINC PLT.,.879 OD, .509 I	4.000 EA
XY5013A12	NUT,1/2-13,HEX,STEEL,ZINCPLATED	4.000 EA
09FN3001B03SP	EXTERNAL FAN, PLASTIC (COMES W/SCREW FRO	1.000 EA
HW2500A25	WOODRUFF KEY USA #1008 #BLOW CARBON STEE	1.000 EA
MJ1000A02	GREASE, MOBIL POLYREX EM - 124047	0.200 LB
12EP1107A196	FREP W/SLINGER & "0" DRAIN,W/O RET HLS	1.000 EA
HA3400A13	STUD, 1/2-13 X 7" WELKER	4.000 EA
HW1001A50	LOCKWASHER 1/2, ZINC PLT.,.879 OD, .509 I	4.000 EA
HW4600B41	V-RING SLINGER 2.125 X 2.880 X 0.280	1.000 EA
HW5100A13	W4627-047 WVY WSHER	1.000 EA
HA4017A01	1/8 X 4 GREASE EXT (F/S)	1.000 EA
HA4051A00	PLASTIC CAP FOR GREASE FITTING	1.000 EA
HW4500A21	1618BALEMITE FITTING 825 UNIVERSAL	1.000 EA
HW4500A17	317400 ALEMITE GREASE RELIEF	1.000 EA

Parts List (continued)		
Part Number	Description	Quantity
HA4066A01	PUSH IN T-DRAIN FITTING (BLACK)	1.000 EA
12EP1106A77	PU ENDPLATE, MACH FOR "O" DRAIN	1.000 EA
HW1001A50	LOCKWASHER 1/2, ZINC PLT.,.879 OD, .509 I	4.000 EA
10XN5013K28	1/2-13 X 1.75 HEX HEAD MACH SCREW,GRAD	4.000 EA
HW4600B41	V-RING SLINGER 2.125 X 2.880 X 0.280	1.000 EA
10XN3118K40	5/16-18 X 2.50" HEX HD, GRADE 5	4.000 EA
HW1001A31	LOCKWASHER 5/16, ZINC PLT.591 OD, .319 I	4.000 EA
HA4051A00	PLASTIC CAP FOR GREASE FITTING	1.000 EA
HW4500A03	GREASE FITTING, .125 NPT 1610(ALEMITE) 8	1.000 EA
HW4500A17	317400 ALEMITE GREASE RELIEF	1.000 EA
HA4066A01	PUSH IN T-DRAIN FITTING (BLACK)	1.000 EA
10CB3001	CONDUIT BOX CAST W/2.500 LEAD HOLE	1.000 EA
09GS1000SP	GASKET-CONDUIT BOX, 1/16 THICK LEXIDE	1.000 EA
10XN3118K16	5/16-18 X 1' GRADE #5, STL, ZINC PLATE	4.000 EA
HW1001A31	LOCKWASHER 5/16, ZINC PLT.591 OD, .319 I	4.000 EA
WD1000B25	GND LUG, BURNDY L125HP OR T&B L125HP-BB	1.000 EA
19XW3118G08	.31-18X.50,HEX WSHR HD,TAPTITE 2,GREEN	1.000 EA
10CB3500SP	CONDUIT BOX LID, CAST	1.000 EA
10GS1000SP	GASKET, CONDUIT BOX LID	1.000 EA
51XW2520A12	.25-20 X .75, TAPTITE II, HEX WSHR SLTD	4.000 EA
MG1025L14	WILKOFAS, 776.14, GRUNDFOS BLACK	0.125 GA
12PA1000	PACKAGING GROUP PRINT PK1024A07	1.000 EA
HW2501H33	KEY, 1/2 SQ X 3.875	1.000 EA

AC Induction Motor Performance Data

Record # 70659

Typical performance - not guaranteed values

Winding: 12WGY454-R009		Type: 1264M	Enclosure: TEFC
Nameplate Data		575 V, 60 Hz: Single Voltage Motor	
Rated Output (HP)	30	Full Load Torque	133 LB-FT
Volts	575	Start Configuration	direct on line
Full Load Amps	30.9	Breakdown Torque	333 LB-FT
R.P.M.	1180	Pull-up Torque	142 LB-FT
Hz	60 Phase	Locked-rotor Torque	186 LB-FT
NEMA Design Code	A KVA Code	Starting Current	187 A
Service Factor (S.F.)	1	No-load Current	13.4 A
NEMA Nom. Eff.	93 Power Factor	Line-line Res. @ 25°C	0.364 Ω
Rating - Duty	40C AMB-CONT	Temp. Rise @ Rated Load	55°C
S.F. Amps		Temp. Rise @ S.F. Load	67°C
		Locked-rotor Power Factor	27.7
		Rotor inertia	12.2 LB-FT ²

Load Characteristics 575 V, 60 Hz, 30 HP

% of Rated Load	25	50	75	100	125	150
Power Factor	43	64	73	78	80	81
Efficiency	86.9	91.8	92.7	92.6	92	90.6
Speed	1195	1192	1188	1183	1178	1172
Line amperes	15.1	19.2	24.7	30.9	38	47.5

Performance Graph at 575V, 60Hz, 30.0HP Typical performance - Not guaranteed values

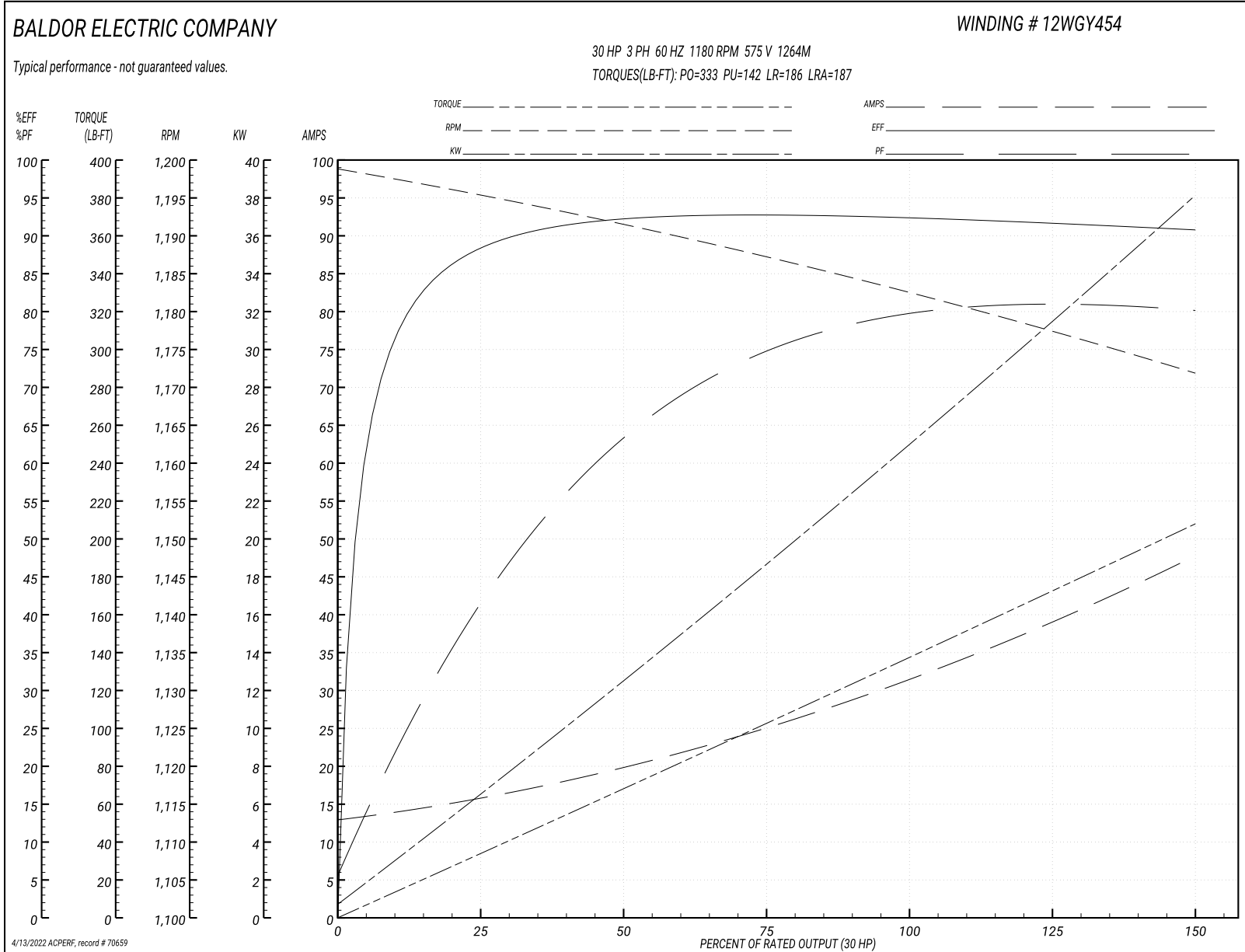

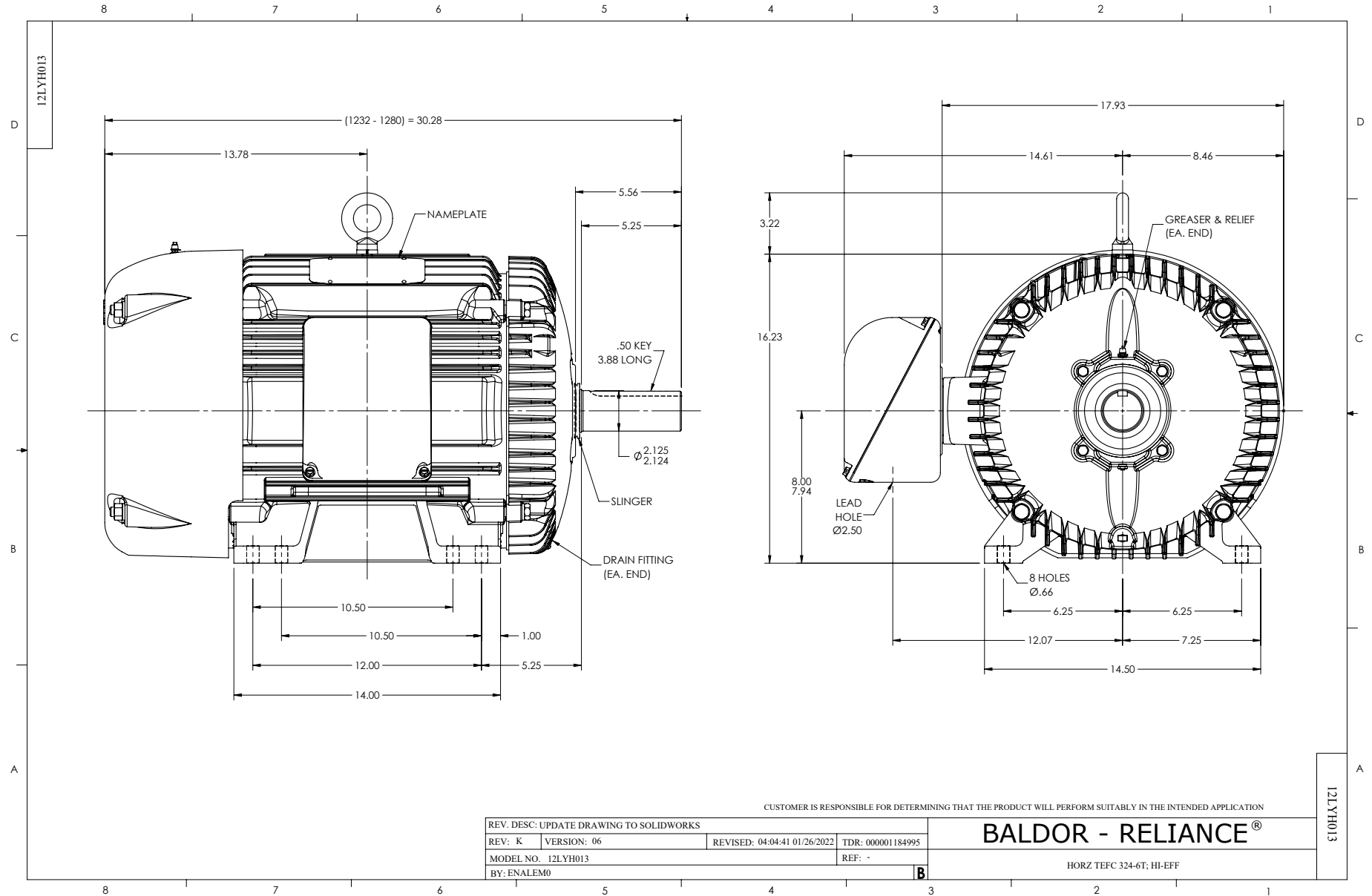

CD0006



NOTES:

1. THREE LEAD MOTOR MAY BE EITHER WYE CONNECTED OR DELTA CONNECTED.
2. INTERCHANGE ANY TWO LINE LEADS TO REVERSE ROTATION.
3. OPTIONAL THERMOSTATS ARE PROVIDED WHEN SPECIFIED.
4. ACTUAL NUMBER OF INTERNAL PARALLEL CIRCUITS MAY VARY.
5. LEAD COLORS ARE OPTIONAL. LEADS MUST BE NUMBERED AS SHOWN.

CD0006

REV. DESC: ADD CLASS CONN00000007		
REV. LTR: E	VERSION: 01	TDR: 000001099922
FILE: \AAA\00005\141	REVISED: 10:24:49 02/19/2019	BY: ENBRIRO
MTL: -	© □	

BALDOR - RELIANCE®

3PH, SV, 3 LEADS, WYE OR DELTA CONNECTED

SH 1 of 1

Marketing maintained PDF of MN416:

<http://www.baldor.com/support/Literature/Load.ashx/MN416?ManNumber=MN416>